

SECTION E

COMMUNICATION PORTS

Revision Date: 12-11-24

DESCRIPTION OF OPERATION

Ethernet Port ENET1 uses the Modbus TCP protocol and is for connection to a SCADA system.

Ethernet Port ENET2 uses the Modbus TCP protocol and is for connection to the SC5000-CTS-HMI. (Where the SC5000-CTS-HMI is a Color Touchscreen Interface.)

RS232 Port COM1 uses the Modbus RTU protocol and is for connection to the SC5000-LED-HMI. (Where the SC5000-LED-HMI is an LED 5 digit Numerical Interface intended for use in Level Control applications in non-temperature controlled control panels.)

The Controller's Communication Ports operate as Modbus Slaves, where all communication is initiated by the device connected to them, which must be a Modbus Master.

MODBUS Functions Supported

Function Code	Function Description	Notes
01	Read Coil Status	
02	Read Input Status	
03	Read Holding Registers	
04	Read Input Registers	
05	Force Single Coil	
06	Preset Single Register	
08	Diagnostics - Sub-function 00 (Return Query Data)	
15	Force Multiple Coils	Limited to 104 Coils
16	Preset Multiple Registers	Limited to 35 Registers

Notes:

- The Controller has a "Parameter Security" feature that guards the Controller's Setup Parameters from unauthorized tampering. If the Parameter Security is locked, the entry of a 48 bit Security Code is required in order to gain Write Access to the Setup Parameters.
- Security Code entry is not required to simply view the Parameters, but if they are locked, entry of the Security Code is required to change them.
- Each of the three Communication Ports have their own Parameter Security that may be locked or unlocked individually to gain Write Access through the respective Communication Port.
- For Ethernet Port ENET1 (connected to SCADA), Parameter Security, if locked, provides Write Access protection for the Modbus Registers (Setup Parameters) and also protects the Modbus Coils (Control Bits).
- For Ethernet Port ENET2 and RS232 Port COM1 (connected to a local HMI), Parameter Security, if locked, provides Write Access protection for the Modbus Registers (Setup Parameters), but always allows Write Access to all Modbus Coils (Control Bits).
- Ethernet Port ENET1 also has a "Parameter Security Alert" feature that detects an Unusually High Number of Entries (100 or more) into the Security Code Entry Parameters (SCE1, SCE2 and SCE3) and locks out any further attempts to write to Parameters SCE1, SCE2 and SCE3.
- The Controller will always allow a reset of Fault Codes, even if the respective Communication Port is locked.
- For a detailed description of "Parameter Security" see Section G.

REMOTE CONTROL COMMAND CANCELING

Remote control commands should (in most applications) be automatically canceled upon a loss of communication with either the SCADA system or the local HMI device. This requires that there be a delay before canceling the remote control commands that is longer than the interval between polling events. Therefore, each of the Communication Ports has its own "Remote Control Command Canceling Delay" Parameter (E.011 - E.013) where an operator may set the delay.

The Following Occurs when one of the Communication Ports stops being poled by its Master and when the respective Remote Control Canceling Delay has expired:

The value entered as the Default Remote Level (Parameter E.015) is copied into the Remote Control Level Input (Parameter rc.02).

Pump 1-6 Force On - All Pump Force On Commands are Canceled.

Pump 1-6 Disable - All Pump Disable Commands are Canceled.

Relays ROX1 - ROX12 Remote Control - All Relay Remote Control Commands are Canceled.

User / Operator Info.			SCADA	Description of Parameters and SCADA Notes
Parameter	Default Value	Current Value	Register Address	
Remote Control Command Canceling Delays				
E.011	60 sec.		40181	Remote Control Command Canceling Delay - Ethernet Port - ENET1 Delay Range: 1 - 65535 seconds Set to "0" to disable the Remote Control Command Canceling feature. See Note 3.
E.012	60 sec.		40182	Remote Control Command Canceling Delay - Ethernet Port - ENET2 Delay Range: 1 - 65535 seconds Set to "0" to disable the Remote Control Command Canceling feature. See Note 3.
E.013	60 sec.		40183	Remote Control Command Canceling Delay - RS232 Port - COM1 Delay Range: 1 - 65535 seconds Set to "0" to disable the Remote Control Command Canceling feature. See Note 3.
Default Remote Level				
E.015	0.0 feet		40185	Default Remote Level See Note 4. Range: 0.0 - 231.0 feet

Notes:

- Each Ethernet Port has its own separate "Remote Control Command Canceling Delay". The delay for each port is reset and restarted each time a successful polling event occurs through that port.
- Each of the delays must be set long enough so that it will not time out between polling events of the port.
- It may be desirable to not cancel the remote control commands upon a loss of communication through one of the ports. In this case set the Remote Control Command Canceling Delay Parameter to "0" for that port, so that a loss of communication through that port will not initiate the canceling of the remote control commands.
- The "Default Remote Level" (Parameter E.015) is only used when the Controller is operating in the "Level Control Mode" (Parameter P.091 = 1) and when the "Level Input Select" is set for "Remote Level Control" (Parameter P.133 = 7).
- Upon loss of power, all remote control commands will be canceled. When power is restored the Default Remote Level (Parameter E.015) will be copied to the Remote Control Level Input (Parameter rc.02).

ETHERNET PORT - ENET1 - For Connection to a SCADA System

Description

The Ethernet Port has the following features:

- Protocol Supported: Modbus TCP
- IEEE 802.3 Compliant
- Auto-negotiation of Communication Speed: 10 or 100 Mbps
- Auto-negotiation of Duplex Mode: Half or Full Duplex
- Link, and Active status LED indicators

LED Indicator	OFF	ON
LINK (Green)	Not Linked	Linked
ACTIVE (Yellow)	Idle	Active Communication

RJ45 Connector

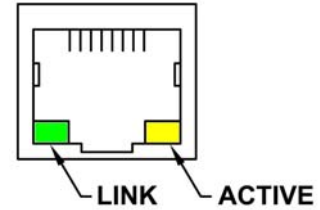

User / Operator Info.		Scada	Parameter Definitions
Parameter	Default Value	Register Address	
Ethernet Port ENET1 Setup			
E.101	2	40200	Protocol 2 = Modbus TCP
E.114 - E.111	192 . 168 . 80 . 12 (E.114 . E.113 . E.112 . E.111)	40204-40201	IP Address Range: 0 -255 Identifier for the device on an IP network.
E.144 - E.141	255 . 255 . 255 . 0 (E.144 . E.143 . E.142 . E.141)	40226-40223	Subnet Mask Range: 0 -255 Range of IP addresses that can be Directly connected in the network.
E.154 - E.151	192 . 168 . 80 . 1 (E.154 . E.153 . E.152 . E.151)	40230-40227	Default Gateway Range: 0 -255 A node on the network that serves as an entrance to another network when no direct connection exists.
E.161	502	40232	Port Number Range: 1 -65,535
Ethernet Port ENET1 MAC Address			
E.176 - E.171	0 : 80 : 194 : 219 : XXX : XXX (E.176 : E.175 : E.174 : E.173 : E.172 : E.171)	40222-40217	MAC Address Unique number that identifies each field device. It is set at the factory, and should not be changed.

Note:

The Ethernet Port reads the setup values upon power up; any changes to the above settings require that the power to be cycled before the new values are used.

ETHERNET PORT - ENET2 - For Connection to the SC5000-CTS-HMI

Description

The Ethernet Port has the following features:

- Protocol Supported: Modbus TCP
- IEEE 802.3 Compliant
- Auto-negotiation of Communication Speed: 10 or 100 Mbps
- Auto-negotiation of Duplex Mode: Half or Full Duplex
- Link, and Active status LED indicators

LED Indicator	OFF	ON
LINK (Green)	Not Linked	Linked
ACTIVE (Yellow)	Idle	Active Communication

RJ45 Connector

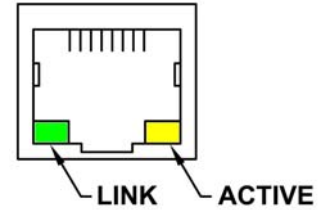

User / Operator Info.		Scada	Parameter Definitions
Parameter	Default Value	Register Address	
Ethernet Port ENET2 Setup			
E.201	2	40250	Protocol 2 = Modbus TCP
E.214 - E.211	192 . 168 . 80 . 12 (E.214 . E.213 . E.212 . E.211)	40254-40251	IP Address Range: 0 - 255 Identifier for the device on an IP network.
E.244 - E.241	255 . 255 . 255 . 0 (E.244 . E.243 . E.242 . E.241)	40276-40273	Subnet Mask Range: 0 - 255 Range of IP addresses that can be Directly connected in the network.
E.254 - E.251	192 . 168 . 80 . 1 (E.254 . E.253 . E.252 . E.251)	40280-40277	Default Gateway Range: 0 - 255 A node on the network that serves as an entrance to another network when no direct connection exists.
E.261	502	40282	Port Number Range: 1 - 65,535
Ethernet Port ENET2 MAC Address			
E.276 - E.271	0 : 80 : 194 : 219 : XXX : XXX (E.276 : E.275 : E.274 : E.273 : E.272 : E.271)	40272-40267	MAC Address Unique number that identifies each field device. It is set at the factory, and should not be changed.

Note:

The Default Setup Values (shown above) are used to connect with the Local Touchscreen HMI. They are set at the factory to match the setup of the SC5000-CTS-HMI and can not be changed in the field using the SC5000-CTS-HMI.

RS232 PORT - COM1 - For Connection to the SC5000-LED-HMI

Description

The RS232 Port COM1 has the following features:

- Protocol Supported: Modbus RTU
- Connector: RJ45 for use with a Shielded CAT5 or CAT6 Patch Cable
- Setup Parameters: Factory set to match the SC5000-LED-HMI

Factory Settings:

Baud Rate: 9600 bps
 Parity Mode: No Parity
 Stop Bits: 1

User / Operator Info.			SCADA	Description of Parameters and SCADA Notes
Parameter	Default Value	Current Value	Register Address	
RS232 Port COM1 Slave Address Setup				
E.347	1		40347	Slave Address - COM1 Range: 1 - 247 Note: COM1 will always respond to what is set on Parameter E.347. COM1 will also always respond to Modbus request using the Slave Address "1". (The SC5000-LED-HMI uses Slave Address "1" to communicate with the SC5000.)

Connection Diagram

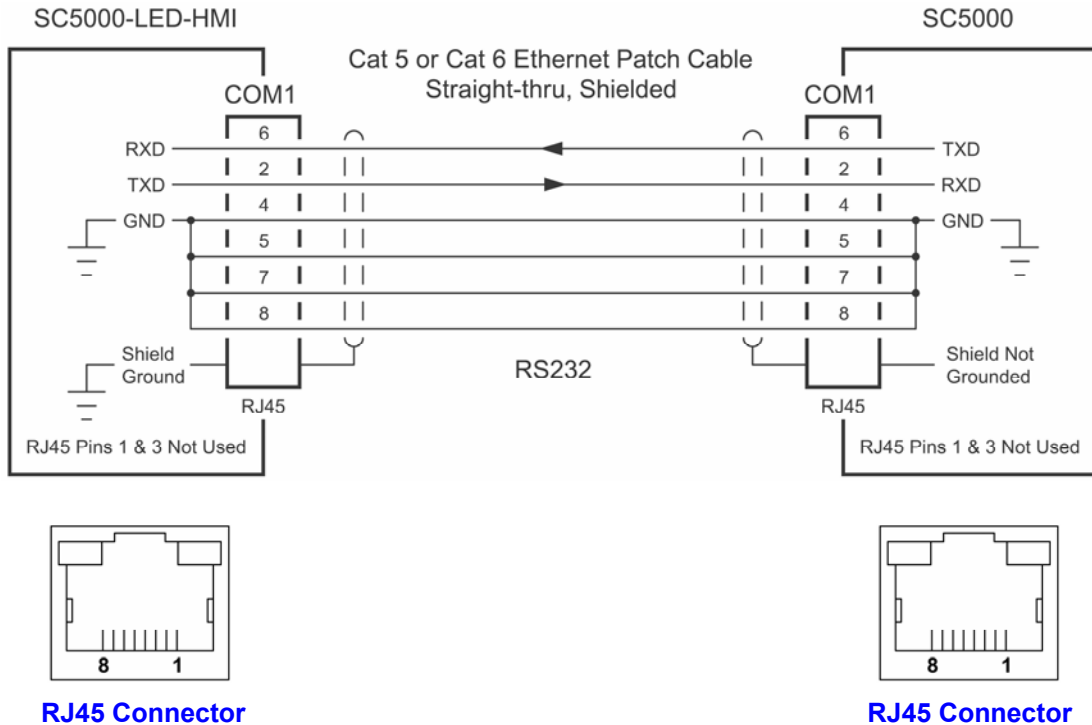

COMMUNICATION PORTS - Touchscreen HMI SCREENS

ETHERNET PORT - ENET1

ENET1 IS USED TO COMMUNICATE WITH SCADA.

Previous Screen

PROTOCOL		IP ADDRESS	
123 <small>Parameter: E.101</small>		123 . 123 . 123 . 123 <small>Parameter: E.114 E.113 E.112 E.111</small>	
PORT NO.	SUBNET MASK		
12345 <small>Parameter: E.161</small>	123 . 123 . 123 . 123 <small>Parameter: E.144 E.143 E.142 E.141</small>		
MAC ADDRESS	DEFAULT GATWAY		
123 : 123 : 123 : 123 : 123 : 123 <small>Parameter: E.176 E.175 E.174 E.173 E.172 E.171</small>	123 . 123 . 123 . 123 <small>Parameter: E.154 E.153 E.152 E.151</small>		

ETHERNET BOARD - ENET1

Operating Program Revision Number	12345 <small>Parameter: d.116</small>	12345 <small>Parameter: d.117</small>	Polling Counter
--------------------------------------	------------------------------------------	------------------------------------------	-----------------

Next Screen

ETHERNET PORT - ENET2

ENET2 IS USED TO COMMUNICATE WITH THE SC5000-CTS-HMI.

Previous Screen

PROTOCOL		IP ADDRESS	
123 <small>Parameter: E.201</small>		123 . 123 . 123 . 123 <small>Parameter: E.214 E.213 E.212 E.211</small>	
PORT NO.	SUBNET MASK		
12345 <small>Parameter: E.261</small>	123 . 123 . 123 . 123 <small>Parameter: E.244 E.243 E.242 E.241</small>		
MAC ADDRESS	DEFAULT GATWAY		
123 : 123 : 123 : 123 : 123 : 123 <small>Parameter: E.276 E.275 E.274 E.273 E.272 E.271</small>	123 . 123 . 123 . 123 <small>Parameter: E.254 E.253 E.252 E.251</small>		

ETHERNET BOARD - ENET2

Operating Program Revision Number	12345 <small>Parameter: d.118</small>	12345 <small>Parameter: d.119</small>	Polling Counter
--------------------------------------	------------------------------------------	------------------------------------------	-----------------

SETUP PARAMETERS
FIXED AT THE FACTORY
TO ENSURE
COMMUNICATION WITH
THE SC5000-CTS-HM.

Next Screen

COMMUNICATION PORTS - Touchscreen HMI SCREENS

RS232 PORT - COM1

COM1 IS USED TO COMMUNICATE WITH THE SC5000-LED-HMI.

Previous Screen

SLAVE ADDRESS	<input style="width: 90%;" type="text" value="123"/>	} FIXED AT THE FACTORY TO ENSURE COMMUNICATION WITH THE SC5000-LED-HMI.			
Parameter: E.347					
PROTOCOL	<input style="width: 90%;" type="text" value="Modbus RTU"/>				
BAUD RATE	<input style="width: 90%;" type="text" value="9600 bps"/>				
PARITY MODE	<input style="width: 90%;" type="text" value="No Parity"/>				
STOP BITS	<input style="width: 90%;" type="text" value="1"/>				

COM1

12345

Polling Counter
Parameter: d.121

LAST INCOMMING MODBUS MESSAGE

12345

12345

12345

12345

12345

12345

12345

12345

12345

12345

12345

Next Screen

COMMUNICATION SETUP

Previous Screen

Remote Control Command Canceling Delays (seconds)

ENET1	<input style="width: 90%;" type="text" value="12345"/>				
Parameter: E.011					
ENET2	<input style="width: 90%;" type="text" value="12345"/>				
Parameter: E.012		Delay Range: 1 - 65535 seconds			
COM1	<input style="width: 90%;" type="text" value="12345"/>	To Disable Remote Control Command Canceling for one or more Ports set the Respective Delay Parameter E.011, E.012, or E.013 to 0.			
Parameter: E.013					

Default Remote Level	<input style="width: 90%;" type="text" value="123.4"/>				
Parameter: E.015		Range: 0.0 - 231.0 feet			