

# SECTION A

## DISCRETE INPUTS

Revision Date: 7-22-24

### DESCRIPTION OF OPERATION

#### Introduction

Discrete Inputs D1 - D12 are provided to allow for the connection of relay contacts or switch contacts to the Controller to provide either a Control Function or to provide the input's status to SCADA or to do both. For Terminal Block numbers see page A-9.

#### Determining Status

The Controller monitors each Discrete Input to see if it has either +24VDC applied or no voltage applied.

When the Discrete Input has +24VDC applied it is considered Closed or "1".

When the Discrete Input has 0.0VDC applied it is considered Open or "0".

#### Status

The status of the Discrete Inputs is made available to be read by SCADA and is available in the menu from Parameters n.01 - n.12.

See pages A-7 & A-8.

#### Functions

The Discrete Inputs are assigned default Functions from the factory, but they may be changed by the operator using Parameters F.01 - F.12.

While each of the Discrete Inputs may be assigned to perform a Function, if a Function is assigned to more than one input, the Fault indicator will come on and Fault Code 1018 will be generated. Function "0" is the exception to this rule. Any or all of the Discrete Inputs may be assigned Function "0".

See page A-6 and see "DISCRETE INPUT FUNCTIONS" below for a description of each of the Functions.

### DISCRETE INPUT FUNCTIONS

#### Collect Discrete Data for SCADA - Function 0

All of the Discrete Inputs collect data for SCADA, regardless of the Function assigned to them, but when a Discrete Input is assigned the Function of "Collect Discrete Data for SCADA" (Function 0) no other action (no Control Function) will be performed by the Controller.

See pages A-7 & A-8.

#### Pump 1 (2, 3) Disable - Functions 1 - 3

When a Discrete Input assigned the Function of "Pump 1 (2, 3) Disable" (Functions 1-3) is closed, the logic in the Controller considers the pump Disabled or not available for service and will not call the pump to run.

When a pump is Disabled the logic in the Controller will skip it in the pump call sequence and call the next available pump in its place.

With the Discrete Input Pump Disable Mode (Parameter F.19) set on "1" the Pump Disable Functions act to disable the respective pump when the Discrete Input is open rather than closed.

Discrete Inputs assigned Functions 1-3 are typically connected to pump fault contacts or pump out of service contacts such as contacts on an HOA switch that closes in the Off and Hand position. Pump fault contacts and pump out of service contacts may also be combined.

## DISCRETE INPUT FUNCTIONS

### External Alternation - Group 1 - Function 4

Each time the Discrete Input assigned the Function of “External Alternation - Group 1” (Function 4) transitions from open to closed, alternation of the pumps in Group 1 will occur. If no pumps were running when the Discrete Input is closed, the alternation of the designated lead pump will still occur.

Function 4 only applies when the Alternation Sequence Mode (Parameter P.16) is set on 1 or 3.

A Discrete Input assigned Function 4 is typically connected to output contacts from an External Time Clock.

### External Alternation - Group 2 - Function 5

Each time the Discrete Input assigned the Function of “External Alternation - Group 2” (Function 5) transitions from open to closed, alternation of the pumps in Group 2 will occur. If no pumps were running when the Discrete Input is closed, the alternation of the designated lead pump will still occur.

Function 5 only applies when the Alternation Sequence Mode (Parameter P.16) is set on 2.

A Discrete Input assigned Function 5 is typically connected to output contacts from an External Time Clock.

### On Generator - Function 6

In cases where the Emergency Generator is not sized large enough to run all the available pumps, closing a Discrete Input assigned the Function of “On Generator” (Function 6) will limit the number of pumps called to run to the “Maximum Number of Pumps Allowed to Run While On Generator” (Parameter P.15).

A Discrete Input assigned Function 6 must be connected to contacts from the Generator Transfer Switch that close when on emergency power.

### All Pump Disable - Function 7

When the Discrete Input assigned the Function of “All Pump Disable” (Function 7) is closed, all pump operation will be disabled (not allowed to run), and Fault Code 1031 will be generated.

When the “All Pump Disable” Discrete Input opens, the time set on the Start Up Delay (Parameter P.32) must first expire before the Controller will enable any pump operation. If a pump is turned on after the Start Up Delay, the Lag Pump Delay (Parameter P.33) must first expire before another pump is called to run, and before each additional pump is called to run.

A Discrete Input assigned Function 7 is typically connected to Phase Monitor contacts that are closed during a fault condition.

### Sequence Input 1 (2, 3) - Functions 8 - 10

When a Discrete Input assigned the Function of “Sequence Input 1 (2, 3)” (Functions 8 - 10) is closed, the order that the pumps are called to run is fixed so that the selected pump is always the lead pump in the Group.

Discrete Inputs assigned Functions 8 - 10 must be connected to contacts on either one or two lead selector switches. See Lead Select Switch Examples on page A-10.

## DISCRETE INPUT FUNCTIONS

### Low Level Alarm Only - Function 11

When a Discrete Input assigned the Function of “Low Level Alarm Only” (Function 11) is closed, the Low Level Alarm will be activated but pump operation will not be disabled. Also see Function 13.

When a Discrete Input assigned the Function of “Low Level Alarm Only” (Function 11) is closed an Output Relay (ROX1 - ROX5), assigned Relay Output Function 2, will close its contacts.

The status of the Low Level Alarm may be read from Modbus Coil 128 (Register 40008 Bit 15) and from Modbus Coil 2 (Register 40001 Bit 1).

A Discrete Input assigned Function 11 is typically connected to a Float Switch that closes upon a Low Level condition.

### High Level Alarm Only - Function 12

When a Discrete Input assigned the Function of “High Level Alarm Only” (Function 12) is closed, the High Level Alarm will be activated. Also see Functions 14 and 19.

When a Discrete Input assigned the Function of “High Level Alarm Only” (Function 12) is closed an Output Relay (ROX1 - ROX5), assigned Relay Output Function 1, will close its contacts.

The status of the High Level Alarm may be read from Modbus Coil 120 (Register 40008 Bit 7) and from Modbus Coil 1 (Register 40001 Bit 0).

A Discrete Input assigned Function 12 is typically connected to a Float Switch that closes upon a High Level condition.

### Pump Cutoff - Low-Low Level (Pump Down Mode) - Function 13

When a Discrete Input assigned the Function of “Pump Cutoff - Low-Low Level” (Function 13) is closed, the Low Level Alarm will be activated, pump operation (Pump Down Mode only) will be disabled and Fault Code 1041 will be generated.

This feature will only operate in the Pump Down Mode (Parameter P.31 = 1).

Pump operation will not be re-enabled until the Low-Low Level input opens and the Pump Re-enable Delay - Pump Cutoff Low-Low Level (Parameter P.35) expires.

When a Discrete Input assigned the Function of “Pump Cutoff - Low-Low Level” (Function 13) is closed an Output Relay (ROX1 - ROX5), assigned Relay Output Function 2, will close its contacts.

The status of the Low Level Alarm may be read from Modbus Coil 128 (Register 40008 Bit 15) and from Modbus Coil 2 (Register 40001 Bit 1).

A Discrete Input assigned Function 13 is typically connected to a Float Switch that closes upon a Low-Low Level condition.

For connection examples see Section I.

### Pump Cutoff - High-High Level (Pump Up Mode) - Function 14

When a Discrete Input assigned the Function of “Pump Cutoff - High-High Level” (Function 14) is closed, the High Level Alarm will be activated, pump operation (Pump Up Mode only) will be disabled and Fault Code 1042 will be generated.

This feature will only operate in the Pump Up Mode (Parameter P.31 = 2).

Pump operation will not be re-enabled until the High-High Level input opens and the Pump Re-enable Delay - Pump Cutoff High-High Level (Parameter P.36) expires.

When a Discrete Input assigned the Function of “Pump Cutoff - High-High Level” (Function 14) is closed an Output Relay (ROX1 - ROX5), assigned Relay Output Function 1, will close its contacts.

The status of the High Level Alarm may be read from Modbus Coil 120 (Register 40008 Bit 7) and from Modbus Coil 1 (Register 40001 Bit 0).

A Discrete Input assigned Function 14 is typically connected to a Float Switch that closes upon a High-High Level condition.

For connection examples see Section I.

## DISCRETE INPUT FUNCTIONS

### Pump Control - Off Level - Function 15

When a Discrete Input assigned the Function of “Pump Control - Off Level” (Function 15) closes, the Pump Control logic will arm itself and be ready to latch in one pump call for each of the “Pump Control - 1st , 2nd, 3rd On Level” inputs that close.

As the “Pump Control - 1st , 2nd, 3rd On Level” inputs open, the pump calls remain latched until the Off Level input also opens, then the latch is broken on all the pump calls, and the pumps are turned off.

A Discrete Input assigned Function 15 is typically connected to a Float Switch that closes as the liquid level arrives at the Off Level.

For Float Control examples see Section I.

### Pump Control - 1ST On Level - Function 16

When a Discrete Input assigned the Function of “Pump Control - 1ST On Level” (Function 16) closes, the Pump Control logic will issue one pump call.

A Discrete Input assigned Function 16 is typically connected to a Float Switch that closes as the liquid level arrives at the 1ST On Level.

For Float Control examples see Section I.

### Pump Control - 2ND On Level - Function 17

When a Discrete Input assigned the Function of “Pump Control - 2ND On Level” (Function 17) closes, the Pump Control logic will issue one pump call.

A Discrete Input assigned Function 17 is typically connected to a Float Switch that closes as the liquid level arrives at the 2ND On Level.

For Float Control examples see Section I.

### Pump Control - 3RD On Level - Function 18

When a Discrete Input assigned the Function of “Pump Control - 3RD On Level” (Function 18) closes, the Pump Control logic will issue one pump call.

A Discrete Input assigned Function 18 is typically connected to a Float Switch that closes as the liquid level arrives at the 3RD On Level.

For Float Control examples see Section I.

### Pump Control - High Level (Pump Down Mode) - Function 19

When a Discrete Input assigned the Function of “Pump Control - High Level (Pump Down Mode)” (Function 19) is closed, the High Level Alarm will be activated.

If the “Pump Control - Off Level” (Function 15) input is closed, closure of the “Pump Control - High Level” (Function 19) will cause the Pump Control logic to issue a pump call to run for all available pumps, with a Lag Pump Delay between each pump call.

Function 19 may only be used in the “Pump Down Mode”, not when in the “Pump Up Mode”.

To form a two float backup system, the “Pump Control - 1st , 2nd, 3rd On Level” inputs may be replaced with the High Level input assigned Function 19. The two float backup system also requires the use of a “Pump Control - Off Level” (Function 15).

If an Output Relay (ROX1 - ROX5) is assigned Function 1, then the Output Relay’s contacts will be closed.

The status of the High Level Alarm may be read from Modbus Coil 120 (Register 40008 Bit 7) and from Modbus Coil 1 (Register 40001 Bit 0).

A Discrete Input assigned Function 19 is typically connected to a Float Switch that closes upon a High Level condition.

For Float Control examples see Section I.

## DISCRETE INPUT FUNCTIONS

### Start Flush Cycle - Function 20

If the Flush Cycle is enabled and set to be activated by an External Time Clock (Parameter P.71 = 2), when a Discrete Input assigned the Function of “Start Flush Cycle” (Function 20) is closed the Flush Cycle will start.

A Discrete Input assigned Function 20 is typically connected to output contacts from an External Time Clock. See Section J.

### Flow Calculator - Start New Day - Function 21

If the Flow Calculator Mode is enabled and set for “External Time Clock” (Parameter P.75 = 2), the Flow Calculator logic will not issue the “Start New Day” command from its internal clock, so it must be initiated externally once each day by an External Time Clock connected to a Discrete Input assigned Function 21.

A Discrete Input assigned the Function of “Flow Calculator - Start New Day” (Function 21) is typically connected to output contacts from an External Time Clock that is programmed to close its output contacts once every 24 hours. See Section K.

### Telemetry A (B, C, D, E, F, G, H, J, K, L, M, N) - Functions 36 - 48

When a Discrete Input is assigned the Function of “Telemetry A (B,C,D,E,F,G,H,J,K,L,M,N)” (Functions 36 - 48), the status of the respective Discrete Input is copied into a specific Coil (Register and Bit) and no other action is performed. See Modbus Registers 40001 and 40008 in Section T.

## DISCRETE INPUTS

| User / Operator Info.       |               | SCADA         |                  | Description of Parameters and SCADA Notes |   |
|-----------------------------|---------------|---------------|------------------|---|---|
| Parameter                   | Default Value | Current Value | Register Address |   |   |
| <b>Discrete Input Setup</b> |               |               |                  |   |   |
| Discrete Input Function     |               |               |                  | Discrete Input                            |   |
| <b>F.01</b>                 | 1             |               | 40301            | Discrete Input - D1                       | <p><b>Function of Discrete Input:</b></p> <p>0 = Collect Discrete Data for SCADA ..... Telemetry Contact<br/>           1 = Pump 1 Disable ..... HOA and Fault Logic<br/>           2 = Pump 2 Disable ..... HOA and Fault Logic<br/>           3 = Pump 3 Disable ..... HOA and Fault Logic<br/>           4 = External Alternation - Group 1 ..... External Time Clock<br/>           5 = External Alternation - Group 2 ..... External Time Clock<br/>           6 = On Generator ..... Automatic Transfer Switch<br/>           7 = All Pump Disable ..... Phase Monitor<br/>           8 = Sequence Input 1 ..... Lead Select Switch - 1 as Lead<br/>           9 = Sequence Input 2 ..... Lead Select Switch - 2 as Lead<br/>           10 = Sequence Input 3 ..... Lead Select Switch - 3 as Lead</p> <p><u>Alarm Only</u></p> <p>11 = Low Level Alarm Only ..... Float Switch<br/>           12 = High Level Alarm Only ..... Float Switch</p> <p><u>Pump Cutoff &amp; Alarm</u></p> <p>13 = Pump Cutoff - Low-Low Level (Pump Down Mode).... Float Switch<br/>           14 = Pump Cutoff - High-High Level (Pump Up Mode) ..... Float Switch</p> <p><u>Pump Control &amp; Alarm</u></p> <p>15 = Pump Control – Off Level ..... Float Switch<br/>           16 = Pump Control – 1st On Level ..... Float Switch<br/>           17 = Pump Control – 2nd On Level ..... Float Switch<br/>           18 = Pump Control – 3rd On Level ..... Float Switch<br/>           19 = Pump Control – High Level (Pump Down Mode).....Float Switch<br/>           20 = Start Flush Cycle ..... External Time Clock<br/>           21 = Flow Calculator - Start New Day ..... External Time Clock</p> <p>36 = Telemetry A ..... Logic Contact<br/>           37 = Telemetry B ..... Logic Contact<br/>           38 = Telemetry C ..... Logic Contact<br/>           39 = Telemetry D ..... Logic Contact<br/>           40 = Telemetry E ..... Logic Contact<br/>           41 = Telemetry F ..... Logic Contact<br/>           42 = Telemetry G ..... Logic Contact<br/>           43 = Telemetry H ..... Logic Contact<br/>           44 = Telemetry J ..... Logic Contact<br/>           45 = Telemetry K ..... Logic Contact<br/>           46 = Telemetry L ..... Logic Contact<br/>           47 = Telemetry M ..... Logic Contact<br/>           48 = Telemetry N ..... Logic Contact</p> <p>Notes:</p> <ol style="list-style-type: none"> <li>Any Discrete Input may be set for Function "0" when the input is used only to collect data for SCADA and no other Function is desired.</li> <li>The status of the Discrete Inputs is made available to be read by SCADA and is available in the menu from Parameters n.01 - n.12. See page 18.</li> <li>For a description of the Functions see pages A-1 - A-5.</li> <li>Pump 1(2,3) Disable logic may be inverted using Parameter F.19.</li> </ol> |
| <b>F.02</b>                 | 2             |               | 40302            | Discrete Input - D2                       |   |
| <b>F.03</b>                 | 3             |               | 40303            | Discrete Input - D3                       |   |
| <b>F.04</b>                 | 4             |               | 40304            | Discrete Input - D4                       |   |
| <b>F.05</b>                 | 5             |               | 40305            | Discrete Input - D5                       |   |
| <b>F.06</b>                 | 6             |               | 40306            | Discrete Input - D6                       |   |
| <b>F.07</b>                 | 7             |               | 40307            | Discrete Input - D7                       |   |
| <b>F.08</b>                 | 8             |               | 40308            | Discrete Input - D8                       |   |
| <b>F.09</b>                 | 9             |               | 40309            | Discrete Input - D9                       |   |
| <b>F.10</b>                 | 10            |               | 40310            | Discrete Input - D10                      |   |
| <b>F.11</b>                 | 11            |               | 40311            | Discrete Input - D11                      |   |
| <b>F.12</b>                 | 12            |               | 40312            | Discrete Input - D12                      |   |

## DISCRETE INPUTS

| User / Operator Info.     |               |               | SCADA            | Description of Parameters  |
|---------------------------|---------------|---------------|------------------|--|
| Parameter                 | Default Value | Current Value | Register Address |  |
| <b>Pump Disable Setup</b> |               |               |                  |  |
| F.19                      | 0             |               | 40319            | Discrete Input Pump Disable Mode<br>0 = Disable Pump with Closed Discrete Input<br>1 = Disable Pump with Open Discrete Input<br>Note: This parameter only applies to Discrete Inputs that are assigned to be Pump Disable Inputs (Discrete Input Functions 1 - 3). |

| User / Operator Info.        |              | SCADA                | Description of Parameters and SCADA Notes                    |
|------------------------------|--------------|----------------------|--|
| Parameter                    | Coil Address |                      |  |
| <b>Discrete Input Status</b> |              |                      |  |
| n.01                         | Coil 545     | Discrete Input - D1  | Discrete Input Status:<br>0 = Input Open<br>1 = Input Closed |
| n.02                         | Coil 546     | Discrete Input - D2  |  |
| n.03                         | Coil 547     | Discrete Input - D3  |  |
| n.04                         | Coil 548     | Discrete Input - D4  |  |
| n.05                         | Coil 549     | Discrete Input - D5  |  |
| n.06                         | Coil 550     | Discrete Input - D6  |  |
| n.07                         | Coil 551     | Discrete Input - D7  |  |
| n.08                         | Coil 552     | Discrete Input - D8  |  |
| n.09                         | Coil 561     | Discrete Input - D9  |  |
| n.10                         | Coil 562     | Discrete Input - D10 |  |
| n.11                         | Coil 563     | Discrete Input - D11 |  |
| n.12                         | Coil 564     | Discrete Input - D12 |  |

## DISCRETE INPUT STATUS

| SCADA Register Address | Description of Register Contents<br>(Where a Modbus Coil is represented by a Bit in a Register) |     |     |     |     |     |     |     |                          |                          |                          |                          |                           |                           |                           |                          |      |
|------------------------|---|-----|-----|-----|-----|-----|-----|-----|--------------------------|--------------------------|--------------------------|--------------------------|---------------------------|---------------------------|---------------------------|--------------------------|------|
|                        | 40035   | 560 | 559 | 558 | 557 | 556 | 555 | 554 | 553                      | 552                      | 551                      | 550                      | 549                       | 548                       | 547                       | 546                      | 545  |
|                        |   |     |     |     |     |     |     |     | Discrete Input D8 Status | Discrete Input D7 Status | Discrete Input D6 Status | Discrete Input D5 Status | Discrete Input D4 Status  | Discrete Input D3 Status  | Discrete Input D2 Status  | Discrete Input D1 Status |      |
| 15                     |   | 14  | 13  | 12  | 11  | 10  | 9   | 8   | 7                        | 6                        | 5                        | 4                        | 3                         | 2                         | 1                         | 0                        | Bit  |
| 40036                  | 576   | 575 | 574 | 573 | 572 | 571 | 570 | 569 | 568                      | 567                      | 566                      | 565                      | 564                       | 563                       | 562                       | 561                      | Coil |
|                        |   |     |     |     |     |     |     |     |                          |                          |                          |                          | Discrete Input D12 Status | Discrete Input D11 Status | Discrete Input D10 Status | Discrete Input D9 Status |      |
|                        | 15  | 14  | 13  | 12  | 11  | 10  | 9   | 8   | 7                        | 6                        | 5                        | 4                        | 3                         | 2                         | 1                         | 0                        | Bit  |

# DISCRETE INPUTS

## Connection Diagram

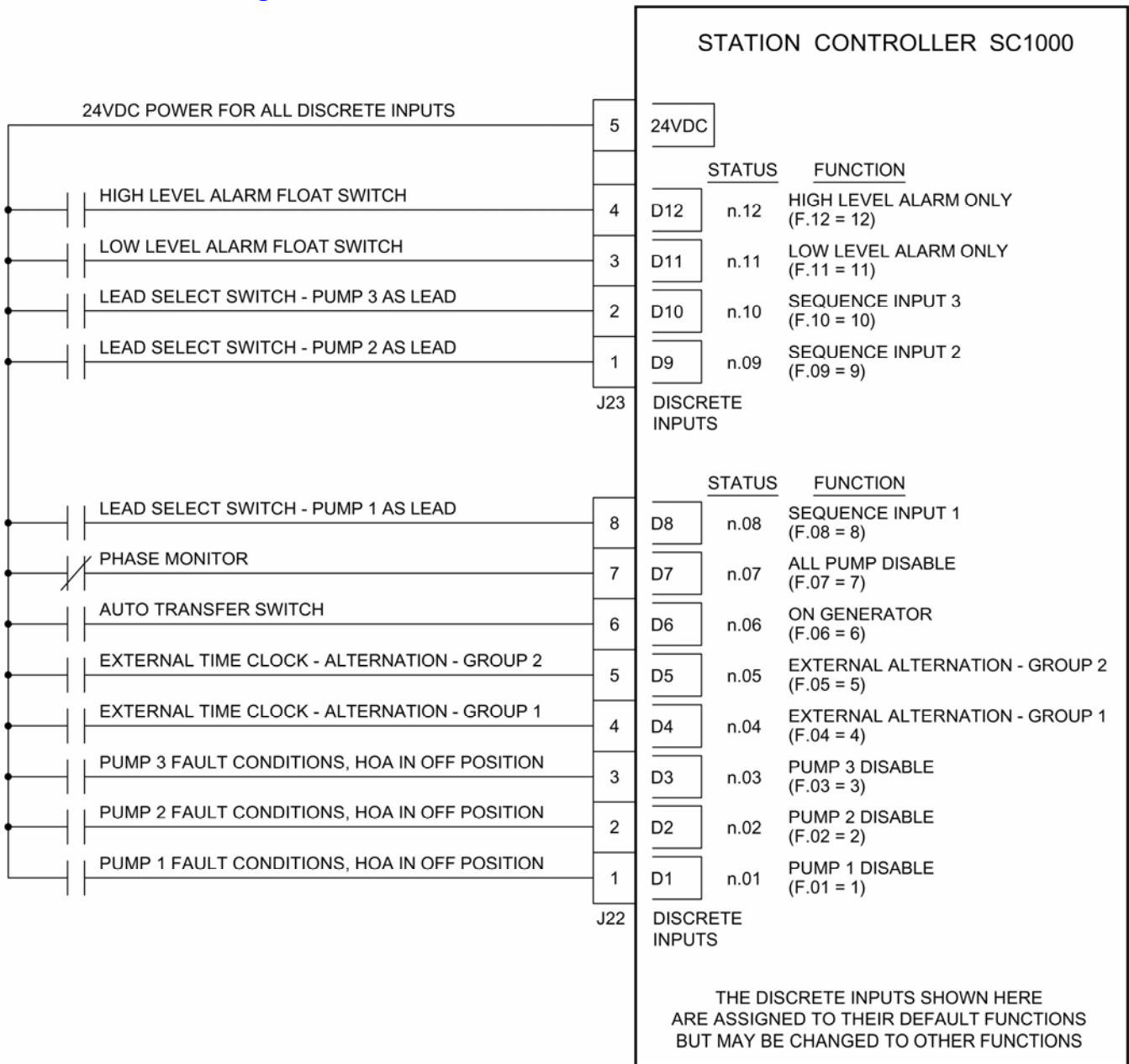

# DISCRETE INPUTS - LEAD SELECT SWITCH EXAMPLES

## Connection Diagrams

### 2 PUMPS - STANDARD ALTERNATION

NUMBER OF PUMPS PRESENT: P.13 = 2  
 ALTERNATION SEQUENCE MODE: P.16 = 1

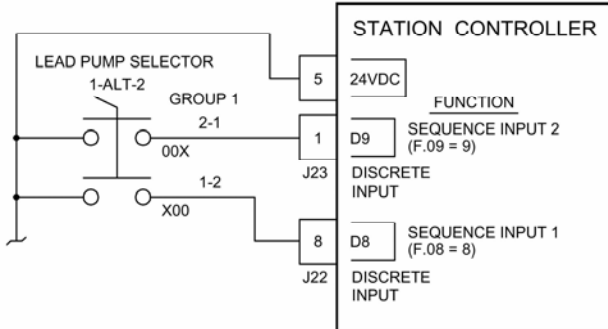

### 3 PUMPS - PUMP 1 ALWAYS LEAD

NUMBER OF PUMPS PRESENT: P.13 = 3  
 ALTERNATION SEQUENCE MODE: P.16 = 2

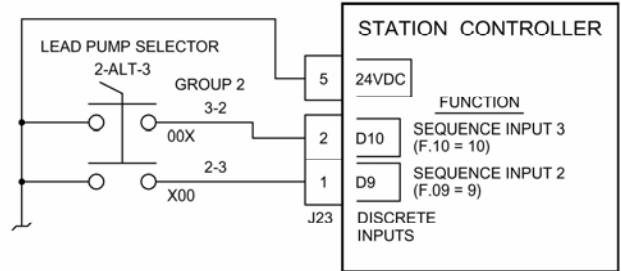

### 3 PUMPS - STANDARD ALTERNATION

NUMBER OF PUMPS PRESENT: P.13 = 3  
 ALTERNATION SEQUENCE MODE: P.16 = 1

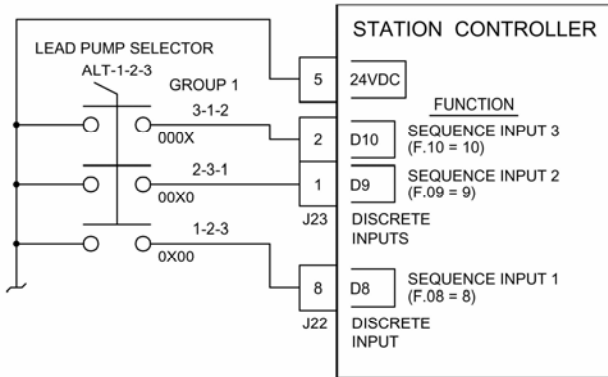

### 3 PUMPS - PUMP 3 ALWAYS LAST

NUMBER OF PUMPS PRESENT: P.13 = 3  
 ALTERNATION SEQUENCE MODE: P.16 = 3

