

SC5000

INSTRUCTION MANUAL

SECTION 1

LEVEL CONTROL

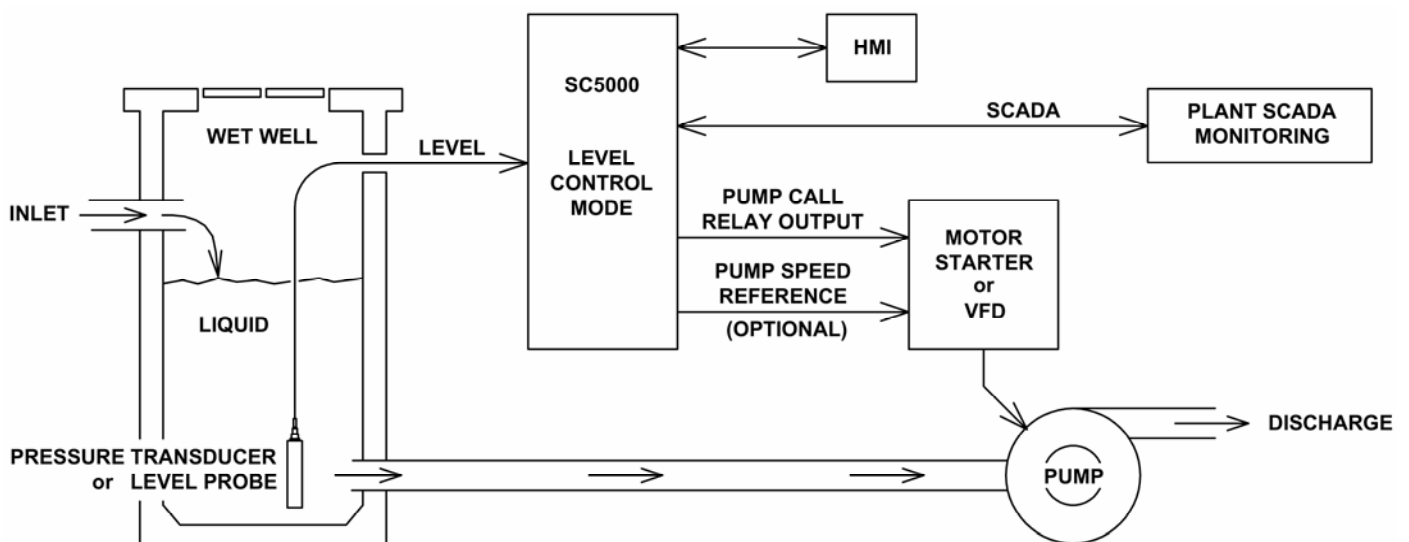

MOTOR PROTECTION ELECTRONICS, LLC

2464 Vulcan Road
Apopka, Florida 32703

Phone: (407) 299-3825
Website: www.mpelectronics.com

SECTION 1

LEVEL CONTROL

TABLE OF CONTENTS

**Page
Number**

DESCRIPTION OF FEATURES

Description of Features Available in the Level Control Mode 1-3

STATION CONTROL SETUP & DATA DISPLAY

Master Control Mode 1-6

Pump Setup 1-6

Level Alarms 1-7

Pump On / Off Levels 1-7

Pump Alternation Setup and Status 1-8

Level Input Setup and Display 1-9

Pump Up or Down Mode 1-10

Lag Pump Delay 1-10

Low Level Alarm Disable 1-10

Re-enable Delay - Pump Cutoff 1-10

Level Simulation 1-11

Remote Control Level Input 1-13

Pump Alternation Sequence 1-14

Analog Level Meters ALM1 and ALM2 L-1

Level Probe Meter LPM1 M-1

VFD SPEED CONTROL

VFD Speed Reference Setup 1-17

FLUSH CYCLE

Flush Cycle Setup 1-18

FLOW CALCULATOR

Flow Calculator Setup and Data Display 1-19

CONNECTION DIAGRAMS

Level Control Example - Analog Level Input 1-25

Level Control Example - Analog Level Input - With VFDs 1-26

Level Control Example - Level Probe Input 1-27

Level Control Example - Float Control - Pump Down and Pump Up 1-28

Float Backup Example - Pump Down and Pump Up 1-30

Lead Pump Selector Switch Examples A-12

Analog Level Input Examples - Single and Dual Transducers M-4

HMI

SC5000-CTS-HMI Screens used for Level Control 1-32

SC5000-LED-HMI Menu used for Level Control X-1

LEVEL CONTROL

DESCRIPTION OF FEATURES

Introduction

With the Master Control Mode (Parameter P.091) set for “Level Control” the SC5000 will function as a lift station level controller, and all logic pertaining to “Flow Control”, “Pressure Control”, “Booster Discharge Pressure Control” and “Booster Supply Pressure Control” will be disabled. In the “Level Control” mode, a variety of control options are available in the setup menu that make the Controller customizable for a large number of applications. It can manage up to 6 pumps and can perform in either a Pump Up or a Pump Down application. With optional Analog Outputs, it can provide a pump speed reference for VFD speed control. The logic in the Controller turns the pumps on or off based on a comparison of the Level Input with the Pump On/Off Level setup parameters. The Controller’s logic alternates the pumps, performs Lag Pump Delays, and provides High Level and Low Level alarms. It has parameters in the menu that allow the operator to set the Number of Pumps Present, the Maximum Number of Pumps Allowed to Run At the Same Time, and the Maximum Number of Pumps Allowed to Run While On a Generator.

HMI Features

SC5000-CTS-HMI

The **SC5000-CTS-HMI** is a **Color Touch Screen** HMI programmed with screens that shows the Wet Well Level, the Pump Call to Run status, the High Level and Low Level alarm status, Parameter Security Write Access status, Fault Codes, and allows an operator to perform Level Simulation. All Setup Parameters for LEVEL CONTROL and I/O Setup are made available on its display screens for the operator to view or change.

SC5000-LED-HMI

The **SC5000-LED-HMI** is a 5 digit numerical LED HMI that shows the Wet Well Level, the Pump Call to Run status, the High Level and Low Level alarm status, Parameter Security Write Access status, Fault indicator that shows when a Fault Code is present, and TX and RX communication activity status. An operator may also perform Level Simulation and a reset of any Fault Codes. All Setup Parameters for LEVEL CONTROL and I/O Setup are made available in its menu for the operator to view or change.

Level Input Select

The Level Input Select (Parameter P.133) allows for the selection of one of the following level input sources: Either one or two analog 4-20mA inputs (Pressure Transducers), a conductance type Level Probe, Float Switches, or a Remote Control Level Input value set through the SCADA system. See Parameter P.133 on page 1-9.

Pump Alternation

Automatic Alternation

In the Level Control Mode the Pump Alternation Sequence Mode is menu selectable and may be set for one of the following: Standard Alternation, Pump 1 Always Lead, Split Alternation - 2&4, Split Alternation - 3&3, or Split Alternation - 4&2. For all of the Alternation Sequence Modes, the alternation of the pumps will be “First On First Off”. With one of the Split Alternation modes selected, the pumps are divided into two groups, Group 1 and Group 2. Where each group of pumps have their own alternation logic. With Split Alternation selected, there is the option of permitting or not permitting Group 1 pumps from running along with pumps from Group 2. See page 1-8.

See the alternation sequence diagrams on pages 1-14, 1-15 & 1-16.

Manual Pump Call Sequence

When manual control over the pump call sequence is desired, the operator can use the Forced Lead Pump Position feature for each Group of pumps to set the Lead Pump Position. This sets the order that the pumps are called in. The Lead Pump Position may also be set using a Lead Pump Selector switch for each Group that is connected to Discrete Inputs assigned to Functions 31-36. See page 1-8.

See connection diagrams on page A-12.

Time Based Alternation

The Controller also supports time based alternation for both Groups 1 and 2. The time based alternation logic may be triggered to alternate by an Internal Time Clock or from an External Time Clock. The Internal Time Clock alternation period is menu selectable. The External Time Clock may be either a hardware device connected to a Discrete Input on the Controller, or it may be part of a SCADA system’s logic, where the SCADA system would set a bit to force the alternation of the pumps. See page 1-8.

LEVEL CONTROL

VFD Speed Control

The VFD Speed Control logic, with optional Analog Outputs, performs proportional control of the pump speed (see Ordering Information on page i-3). The Level versus Pump Speed Curve is established using the following setup parameters: Level at 100% Speed, Level at Minimum Speed and the Minimum Speed setting. With these three parameters, along with the Pump On/Off Level Control parameters, the control range in the wet well that the pumps operate is established. Also provided is a Pump Start Speed Boost feature that may be used ensure that the Check Valve opens upon the start of a pump. See page 1-17.

Flush Cycle

The Flush Cycle feature can be setup to periodically flush the sludge build up from the bottom of the wet well and from the discharge pipe. It does this by maximizing the lift station's discharge flow rate. The flow rate is maximized by allowing the wet well to fill up to the Flush Cycle Start Level, and then by pumping the wet well down to the Flush Cycle Stop Level, with all available pumps running. The Flush Cycle Start Level and the Flush Cycle Stop Level are menu selectable. The Flush Cycle logic may be triggered to start by either an Internal Time Clock or from an External Time Clock. When using the Internal Time Clock, the Delay Between Flush Cycles is menu selectable. If an External Time Clock is used, it may be either a hardware device connected to a Discrete Input on the Controller, or it may be part of a SCADA system's logic, where the SCADA system would set a bit to force the start of the Flush Cycle. The Flush Cycle menu also provides the means to manually start or stop the Flush Cycle. See page 1-18.

Flow Calculator

The Flow Calculator feature provides the following data: Latest Inflow Rate, Inflow Totalizer (with remote reset), Pump 1 - 6 Outflow Rate, Average Daily Inflow Total and has available the Last 7 Days of Daily Inflow Totals. The Flow Calculator's Start New Day command may be setup to be triggered by either an Internal 24 hour Time Clock or from an External 24 hour Time Clock. The External Time Clock may be either a hardware device connected to a Discrete Input on the Controller, or it may be part of a SCADA system's logic where the SCADA system sets the Start New Day bit once each day. See pages 1-19 through 1-24.

LEVEL CONTROL

Discrete Inputs

30 Discrete Inputs (D1 - D30) that may be setup to perform the following Functions:

- Level Probe Inputs
- Pump Disable Inputs
- All Pump Disable - Phase Monitor Input
- On Generator - Limits number of pumps allowed to run
- Switch Between ALM1 & ALM2 for Level Input selection
- Start Flush Cycle - External Time Clock Input
- External Alternation - External Time Clock Input
- Sequence Inputs - Lead Pump Selector Switch Inputs
- Call Pump Last Inputs
- Flow Calculator - Start New Day Time Clock Input
- Pump Cutoff Low-Low Level Input
- Pump Cutoff High-High Level Input
- High and Low Level Alarm Inputs
- Float Control - Float Switch Backup Inputs
- Collection of Discrete Input Data for SCADA

Relay Outputs

12 Relay Outputs (ROX1 - ROX12) that may be setup to perform the following Functions:

- Up to Six Pump Call to Run Outputs
- High or Low Level Alarm Outputs
- SCADA Remote Control Outputs

Analog Inputs

2 Standard Analog Inputs (AIX1 - AIX2) and up to 8 more Optional Analog Inputs (A1 - A8).

The Analog Inputs may be setup to perform one of the following Functions:

- Analog Level Meter ALM1 or ALM2
- Analog Flow Meter AFM1, AFM2 or AFM3
- Analog Pressure Meter APM1 or APM2
- Analog Current Meter ACMA, ACMB or ACMC
- Collection of Analog Input Data for SCADA

Analog Outputs

1 Standard Analog Output (AOX1) and up to 6 more Optional Analog Outputs (AO1 - AO6).

The Analog Outputs may be setup to perform one of the following Functions:

- Analog Signal for Pumps 1 - 6 Speed Reference
- Analog Signal for Pumps Speed Reference any Pump (Always Active)
- Analog Signal that is a Copy of Wet Well Level

Discrete Pulse Counter Inputs

Option for up to 3 Discrete Pulse Counter Inputs (DPC1 - DPC3) that may be used to perform the following:

- Discrete Pulse Counter Input for Pulse Flow Meter PFM1, PFM2 or PFM3

LEVEL CONTROL

| User / Operator Info. | | | SCADA | Description of Parameters |
|----------------------------|---------------|---------------|------------------|---|
| Parameter | Default Value | Current Value | Register Address | |
| Master Control Mode | | | | |
| P.091 | 1 | | 40091 | Master Control Mode 1 = Level Control Must Be Set On "1" for Level Control 2 = Flow Control 3 = Pressure Control 4 = Booster Discharge Pressure Control 5 = Booster Supply Pressure Control |
| Pump Setup | | | | |
| P.092 | 6 | | 40092 | Number of Pumps Present 1 = 1 Pump 2 = 2 Pumps 3 = 3 Pumps 4 = 4 Pumps 5 = 5 Pumps 6 = 6 Pumps |
| P.093 | 6 | | 40093 | Maximum Number of Pumps Allowed to Run at the Same Time 1 = 1 Pump 2 = 2 Pumps 3 = 3 Pumps 4 = 4 Pumps 5 = 5 Pumps 6 = 6 Pumps |
| P.094 | 6 | | 40094 | Maximum Number of Pumps Allowed to Run While On Generator 1 = 1 Pump 2 = 2 Pumps 3 = 3 Pumps 4 = 4 Pumps 5 = 5 Pumps 6 = 6 Pumps Note: Must Connect Transfer Switch Contact to Discrete Input assigned to Function 18. |

LEVEL CONTROL

| User / Operator Info. | | | SCADA | Description of Parameters and SCADA Notes |
|---|---------------|---------------|------------------|---|
| Parameter | Default Value | Current Value | Register Address | |
| Level Alarms | | | | |
| LoAL | 2.0 feet | | 40101 | <p>Low Level Alarm Range: 0.0 - 231.0 feet</p> <p>Notes:</p> <ol style="list-style-type: none"> 1. This sets the level at which the Low Level Alarm will be activated. 2. To disable the Low Level Alarm see Parameter P.151. 3. The Low Level Alarm operation is delayed for 90 seconds after power is applied. 4. The Low Level Alarm does not act as a redundant pump off (for Pump Down). 5. A Float Switch connected to a Discrete Input assigned to either Functions 59 or 61 will also activate the Low Level Alarm. 6. Upon a Low Level Alarm, the contacts of a relay programmed for Function 7 will close. |
| The "Low Level Alarm" status is available from Modbus Coil 47 (Register 40003 Bit 14). | | | | |
| HiAL | 10.0 feet | | 40102 | <p>High Level Alarm Range: 0.5 - 231.0 feet</p> <p>Notes:</p> <ol style="list-style-type: none"> 1. This sets the level at which the High Level Alarm will be activated. 2. The High Level Alarm operation is delayed for 10 seconds after power is applied. 3. The High Level Alarm does not act as a redundant pump off (for Pump Up). 4. A Float Switch connected to a Discrete Input assigned to Functions 60, 62 or 70 will also activate the High Level Alarm. 5. Upon a High Level Alarm, the contacts of a relay programmed for Function 8 will close. |
| The "High Level Alarm" status is available from Modbus Coil 48 (Register 40003 Bit 15). | | | | |
| Pump On / Off Levels | | | | |
| 1PoFF | 3.0 feet | | 40103 | 1st Pump Off Level Range: 0.2 - 231.0 feet |
| 1Pon | 6.0 feet | | 40104 | 1st Pump On Level Range: 0.2 - 231.0 feet |
| 2PoFF | 3.5 feet | | 40105 | 2nd Pump Off Level Range: 0.2 - 231.0 feet |
| 2Pon | 6.5 feet | | 40106 | 2nd Pump On Level Range: 0.2 - 231.0 feet |
| 3PoFF | 4.0 feet | | 40107 | 3rd Pump Off Level Range: 0.2 - 231.0 feet |
| 3Pon | 7.0 feet | | 40108 | 3rd Pump On Level Range: 0.2 - 231.0 feet |
| 4PoFF | 4.5 feet | | 40109 | 4th Pump Off Level Range: 0.2 - 231.0 feet |
| 4Pon | 7.5 feet | | 40110 | 4th Pump On Level Range: 0.2 - 231.0 feet |
| 5PoFF | 5.0 feet | | 40111 | 5th Pump Off Level Range: 0.2 - 231.0 feet |
| 5Pon | 8.0 feet | | 40112 | 5th Pump On Level Range: 0.2 - 231.0 feet |
| 6PoFF | 5.5 feet | | 40113 | 6th Pump Off Level Range: 0.2 - 231.0 feet |
| 6Pon | 8.5 feet | | 40114 | 6th Pump On Level Range: 0.2 - 231.0 feet |

LEVEL CONTROL

| User / Operator Info. | | | SCADA | Description of Parameters and SCADA Notes |
|--------------------------------|---------------|---------------|------------------|---|
| Parameter | Default Value | Current Value | Register Address | |
| Pump Alternation Setup | | | | |
| P.122 | 1 | | 40122 | <p>Alternation Sequence Mode</p> <p>1 = Standard Alternation: Group 1: Pumps 1 - 6 See page 1-14. 2 = Pump 1 Always Lead: Group 1: Pump 1 Group 2: Pumps 2 - 6 See page 1-14. 3 = Split Alternation - 2&4: Group 1: Pumps 1 - 2 Group 2: Pumps 3 - 6 See page 1-15. 4 = Split Alternation - 3&3: Group 1: Pumps 1 - 3 Group 2: Pumps 4 - 6 See page 1-15. 5 = Split Alternation - 4&2: Group 1: Pumps 1 - 4 Group 2: Pumps 5 - 6 See page 1-16.</p> <p>Also see: Alternation Sequence Modifier A (Parameter P.124) below.</p> |
| P.124 | 0 | | 40124 | <p>Alternation Sequence Modifier A</p> <p>0 = Group 1 Pump(s) Are Allowed To Run With Pumps From Group 2 1 = Group 1 Pump(s) Not Allowed To Run With Pumps From Group 2 (Pump(s) in Group 1 are turned off before starting Pumps in Group 2)</p> <p>Note: This applies when Parameter P.122 = 2, 3, 4, or 5</p> |
| P.129 | 0 | | 40129 | <p>Forced Lead Pump Position - Group 1</p> <p>0 = Normal Alternation X = Pump X as Lead</p> <p>Note: This applies to Group 1 when Parameter P.122 = 1, 3, 4, or 5</p> |
| P.130 | 0 | | 40130 | <p>Forced Lead Pump Position - Group 2</p> <p>0 = Normal Alternation X = Pump X as Lead</p> <p>Note: This applies to Group 2 when Parameter P.122 = 2, 3, 4, or 5</p> |
| P.131 | 0 | | 40131 | <p>Time Based Alternation - Group 1 Range: 0 - 65535 minutes</p> <p>0 = Disabled 60 = 1 hour 480 = 8 hours 1440 = 24 hours</p> <p>Note: Group 1 may be triggered to alternate by using the Internal Time Clock setup using Parameter P.131, or it can also be triggered by an External Time Clock, which may be either a hardware device connected to a Discrete Input setup to perform Function 21, or it may be triggered to alternate by having the SCADA system set Bit 14 in Register 40006.</p> |
| P.132 | 0 | | 40132 | <p>Time Based Alternation - Group 2 Range: 0 - 65535 minutes</p> <p>0 = Disabled 60 = 1 hour 480 = 8 hours 1440 = 24 hours</p> <p>Note: Group 2 may be triggered to alternate by using the Internal Time Clock setup using Parameter P.132, or it can also be triggered by an External Time Clock, which may be either a hardware device connected to a Discrete Input setup to perform Function 22, or it may be triggered to alternate by having the SCADA system set Bit 15 in Register 40006.</p> |
| Pump Alternation Status | | | | |
| Ad.01 | - | - | 41888 | Current Lead Pump - Group 1 Shows the number of the current Lead Pump. |
| Ad.02 | - | - | 41889 | Current Lead Pump - Group 2 Shows the number of the current Lead Pump. |

LEVEL CONTROL

| User / Operator Info. | | SCADA | | Description of Parameters and SCADA Notes |
|---|---------------|---------------|------------------|---|
| Parameter | Default Value | Current Value | Register Address | |
| Level Input Setup | | | | |
| P.133 | 1 | | 40133 | <p>Level Input Select</p> <ul style="list-style-type: none"> 1 = Analog Level Meter - ALM1 - Single Transducer 2 = Analog Level Meter - ALM2 - Single Transducer 3 = Analog Level Meter - ALM1 & ALM2 - Dual Transducers - Manual Switching 4 = Analog Level Meter - ALM1 & ALM2 - Dual Transducers - Automatic Switching 5 = Level Probe Meter - LPM1 - Level Probe 6 = Float Switch Inputs 7 = Remote Control Level Input <p>Selection 1 - Level Input is from ALM1. See Section M. Selection 2 - Level Input is from ALM2. See Section M. Selection 3 - Level Input is Manually switched from ALM1 to ALM2. See Section M. Selection 4 - Level Input is Automatically switched from ALM1 to ALM2. See Section M. Selection 5 - Level Probe with 10 Electrodes Connected to 10 Discrete Inputs. See Section L. Selection 6 - Float Switches as the primary (and only) Level Input. See pages 1-28 and 1-29. Selection 7 - Remote Control Level Input written through SCADA to Parameter rc.02. See page 1-13.</p> |
| Level Input Data - Touchscreen HMI Display | | | | |
| Ld.01 | - | - | 42143 | <p>Level Input Data - For Numerical Display of Level</p> <p>Note: This is the value of the Level input selected on Parameter P.133 scaled into feet and 1/10 of feet for numerical display on an HMI.</p> |
| Ld.02 | - | - | 42144 | <p>Level Input Data - For Bar Graph Display of Level</p> <p>Note: This is the value of the Supply Level Input selected on Parameter P.133 scaled for display on a bar graph. It is scaled to a range of 0 - 4095. The Bar Graph Display scaling setup on the HMI device must be set for 0 - 4095.</p> |
| Ld.03 | - | - | 42145 | <p>Level Input Source Status</p> <ul style="list-style-type: none"> 1 = Analog Level Meter - ALM1 2 = Analog Level Meter - ALM2 3 = Level - Simulated 4 = Level Probe Meter - LPM1 5 = Float Switch Inputs 6 = Remote Level Control Input |

LEVEL CONTROL

| User / Operator Info. | | SCADA | | Description of Parameters and SCADA Notes |
|--|---------------|---------------|------------------|---|
| Parameter | Default Value | Current Value | Register Address | |
| Station Control Setup | | | | |
| P.149 | 1 | | 40149 | <p>Pump Up or Down Mode 1 = Pump Down - Empty a Tank 2 = Pump Up - Fill a Tank</p> <p>Note: When Parameter P.149 is changed the following new default setup parameters will be loaded: All Pump On/Off Levels VFD - Level at Minimum Speed VFD - Level at 100% Speed</p> |
| P.150 | 5 sec. | | 40150 | <p>Lag Pump Delay Range: 1 - 100 seconds</p> <p>Note: This is the minimum time period between the calling of pumps to run. It is also used to delay the turning on of the replacement pump when an operating pump is suddenly disabled, or when a time based alternation of the pumps is performed.</p> |
| P.151 | 1 | | 40151 | <p>Low Level Alarm Disable 0 = Disable Low Level Alarm 1 = Enable Low Level Alarm</p> <p>Notes:</p> <ol style="list-style-type: none"> This only disables Low Level Alarms generated from the Analog Level Input, or the Level Probe Input being below the Level Alarm setting on Parameter LoAL, not Low Level Alarms generated from Float Switch inputs assigned Functions 59 or 61. This feature does not operate when the Float Switch Inputs are selected as the primary Level Input Source (Parameter P.133 = 6). |
| P.153 | 10 sec. | | 40153 | <p>Pump Re-enable Delay - Pump Cutoff Low-Low Level Range: 1 - 600 sec.</p> <p>Notes:</p> <ol style="list-style-type: none"> This is only used in the Pump Down Mode (Parameter P.149 = 1). While the Low-Low Level Float Switch is closed no pump operation will be allowed. A Low-Low Level Float Switch must be connected to a Discrete Input assigned to Function 59. The Delay starts timing out when the Discrete Input opens. When the Re-enable Delay expires the Pump Cutoff Low-Low Level feature will no longer prevent pump operation. While the Pump Cutoff Low-Low Level input is closed the Low Level Alarm will be active. The contacts of a relay assigned to the Low Level Alarm (Function 7) will also be closed. Also, Fault Code 1041 will be generated. |
| <p>Activates the "Pump Cutoff Active Low-Low Level". Status is available from Modbus Coil 131 (Register 40009 Bit 2).</p> <p>Also activates the "Low Level Alarm". Status is available from Modbus Coil 47 (Register 40003 Bit 14).</p> | | | | |
| P.154 | 10 sec. | | 40154 | <p>Pump Re-enable Delay - Pump Cutoff High-High Level Range: 1 - 600 sec.</p> <p>Notes:</p> <ol style="list-style-type: none"> This is only used in the Pump Up Mode (Parameter P.149 = 2). While the High-High Level Float Switch is closed no pump operation will be allowed. A High-High Level Float Switch must be connected to a Discrete Input assigned to Function 60. The Delay starts timing out when the Discrete Input opens. When the Re-enable Delay expires the Pump Cutoff High-High Level feature will no longer prevent pump operation. While the Pump Cutoff High-High Level input is closed the High Level Alarm will be active. The contacts of a relay assigned to the High Level Alarm (Function 8) will also be closed. Also, Fault Code 1042 will be generated. |
| <p>Activates the "Pump Cutoff Active High-High Level". Status is available from Modbus Coil 132 (Register 40009 Bit 3).</p> <p>Also activates the "High Level Alarm". Status is available from Modbus Coil 48 (Register 40003 Bit 15).</p> | | | | |

LEVEL SIMULATION - Analog Level Input

The Level Simulation feature is provided to allow an operator to temporarily take manual control of the Level Input used by the Controller to control the pumps and provide high and low level alarms.

The Level Simulation discussed here is what is used when the “Level Input Select” (Parameter P.133) is set for either one of the “Analog Level Meters” (ALM1 or ALM2) or for “Remote Level Control Input” (rc.02), (where Parameter P.133 = 1, 2, 3, 4 or 7).

The Level Simulation starts from the actual level displayed prior to entering the Level Simulation mode.

If you do not exit the Level Simulation mode, normal operation will resume automatically 60 seconds after the last time a new value was entered for the simulated level.

When performing Level Simulation using the SC5000-CTS-HMI (connected to Ethernet Port ENET2) or when using the SC5000-LED-HMI (connected to Serial Port COM1), the operator is permitted to perform Level Simulation even if the “Parameter Write Access” is “LOCKED”. However, when performing Level Simulation through Ethernet Port ENET1 the “Parameter Write Access” must be “UNLOCKED”. ENET1 is intended for connection to a SCADA system, rather than a local HMI, therefore the additional security is necessary. See Page G-1.

Level Simulation - Using the SC5000-CTS-HMI (Color Touch Screen HMI)

On the SC5000-CTS-HMI the Level Simulation feature may be found on the screen for “Station Status”. It is comprised of a touch-button labeled “Push To Start Level Simulation” and the numerical entry screen that pops up when the Numerical Level Display (Parameter rc.01) is pressed.

To Start Level Simulation: Touch the “Push To Start Level Simulation” touch-button.

To Change Simulated Level: Touch the Numerical Level Display and enter the desired value.

To End Level Simulation: Touch the “Level Simulation Active” touch-button.

Level Simulation - Using the SC5000-LED-HMI

On the SC5000-LED-HMI the Level Simulation mode is entered by pressing the push-button labeled “LEVEL SIMULA.”. Changes to the simulated level are made by pressing either the Up or the Down push-buttons.

To Start Level Simulation: Press the “LEVEL SIMULA.” push-button.

To Increase Simulated Level: Push the Up push-button.

To Decrease Simulated Level: Push the Down push-button.

To End Level Simulation: Press the “LEVEL” push-button.

| User / Operator Info. | SCADA | Description of Parameter |
|---|------------------|--|
| Parameter | Register Address | |
| rc.01 | 42001 | Level Simulation - Simulated Level Input |
| To activate the Level Simulation mode set Modbus Coil 103 (Register 40007 Bit 6). | | |

LEVEL SIMULATION - Level Probe Input

The Level Simulation feature is provided to allow an operator to temporarily take manual control of the Level Input used by the Controller to control the pumps and provide high and low level alarms.

The Level Simulation discussed here is what is used when the “Level Input Select” (Parameter P.133) is set for the “Level Probe Meter” (LPM1) (Parameter P.133 = 5). The operator’s changes to the simulated level are made in increments equal to the “Level Probe Meter Electrode Spacing” (Parameter P.520).

The Level Simulation starts from the actual level displayed prior to entering the Level Simulation mode.

If you do not exit the Level Simulation mode, normal operation will resume automatically 60 seconds after the last time a new value was entered for the simulated level.

When performing Level Simulation using the SC5000-CTS-HMI (connected to Ethernet Port ENET2) or when using the SC5000-LED-HMI (connected to Serial Port COM1), the operator is permitted to perform Level Simulation even if the “Parameter Write Access” is “LOCKED”. However, when performing Level Simulation through Ethernet Port ENET1 the “Parameter Write Access” must be “UNLOCKED”. ENET1 is intended for connection to a SCADA system, rather than a local HMI, therefore the additional security is necessary. See Page G-1.

Level Simulation - Using the SC5000-CTS-HMI (Color Touchscreen HMI)

On the SC5000-CTS-HMI the Level Simulation feature may be found on the screen for “Station Status”. It is comprised of a touch-button labeled “Push To Start Level Simulation” and a touch-button for “UP” and a touch-button for “DN” (Down).

To Start Level Simulation: Touch the “Push To Start Level Simulation” touch-button.

To Increase Simulated Level: Touch the “UP” touch-button.

To Decrease Simulated Level: Touch the “DN” touch-button.

To End Level Simulation: Touch the “Level Simulation Active” touch-button.

Level Simulation - Using the SC5000-LED-HMI

On the SC5000-LED-HMI the Level Simulation mode is entered by pressing the push-button labeled “LEVEL SIMULA.”. Changes to the simulated level are made by pressing either the Up or the Down push-buttons.

To Start Level Simulation: Press the “LEVEL SIMULA.” push-button.

To Increase Simulated Level: Push the Up push-button.

To Decrease Simulated Level: Push the Down push-button.

To End Level Simulation: Press the “LEVEL” push-button.

To activate the Level Simulation mode set Modbus Coil 104 (Register 40007 Bit 7).
To decrease the Simulated Level set Modbus Coil 105 (Register 40007 Bit 8).
To increase the Simulated Level set Modbus Coil 106 (Register 40007 Bit 9).

REMOTE CONTROL LEVEL INPUT

The Remote Control Level Input feature is provided to allow an operator to have manual remote control, through a SCADA system, of the Level Input used by the Controller to control the pumps. The Remote Control Level Input feature also allows a SCADA system to send the Controller the Remote Control Level Input value from some remote location.

This feature requires that the “Level Input Select” (Parameter P.133) be set on “Remote Control Level Input” (Parameter P.133 = 7).

With a SCADA system connected to Ethernet Port ENET1, writing to the “Remote Control Level Input” (Parameter rc.02) is not permitted when the “Parameter Write Access” for ENET1 is “LOCKED”. It must be “UNLOCKED” to remotely change the Level Input value.

Using the SC5000-CTS-HMI, connected to Ethernet Port ENET2, to write to the “Remote Control Level Input” (Parameter rc.02) is permitted even if the “Parameter Write Access” for ENET2 is “LOCKED”.

Using the SC5000-LED-HMI, connected to RS232 Port COM1, to write to the “Remote Control Level Input” (Parameter rc.02) is permitted even if the “Parameter Write Access” for COM1 is “LOCKED”.

See details about the “Default Remote Level” (Parameter E.015), and the “Remote Control Command Canceling Delays” (Parameters E.011, E.012 and E.013) on page E-2.

| User / Operator Info. | SCADA | Description of Parameter |
|------------------------------|-------------------------|---------------------------------|
| Parameter | Register Address | |
| rc.02 | 42002 | Remote Control Level Input |

ALTERNATION SEQUENCE MODE

STANDARD ALTERNATION

Parameter P.122 = 1

Unless there is some special circumstance that requires a more complicated pump call sequence, this is the sequence that should be used.

The pumps will be Alternated "First On First Off".

Discrete Inputs assigned the Function of "Pump Disable" (Functions 11-16) inputs may be used to disable pumps so that they will not be called to run.

Discrete Inputs assigned the Function of "Call Pump Last" (Functions 41-46) may be used to assign pumps to standby status, where they will only be called to run if no other pumps are available.

Discrete Inputs assigned the Function of "Sequence Input" (Functions 31-36) may be used to set the lead pump.

The "Forced Lead Pump Position - Group 1" (Parameter P.129) may be used to set the lead pump.

"Time Based Alternation - Group 1" (Parameter P.131) may be setup to force alternation using an Internal Time Clock.

A Discrete Input assigned the Function of "External Alternation - Group 1" (Function 21) may be connected to an External Time Clock and used to force alternation.

A SCADA system may initiate alternation by momentarily setting Modbus Coil 95 (Register 40006, Bit 14).

Movement of Lead Pump Upon Alternation

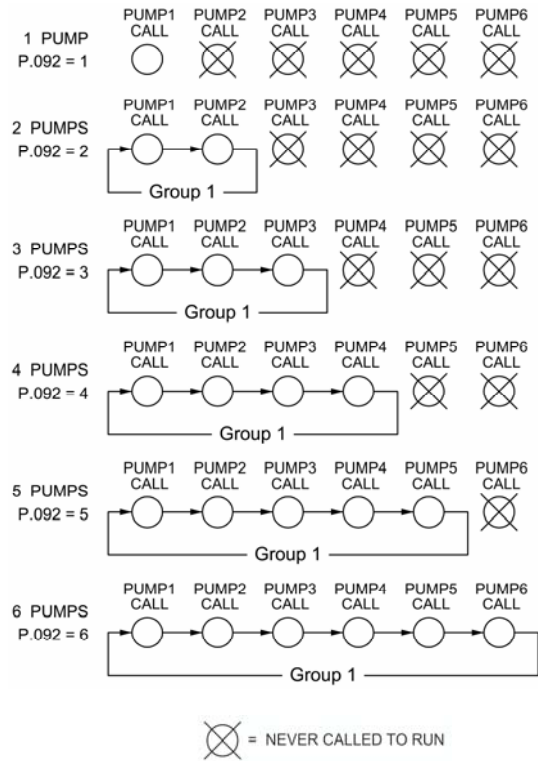

PUMP 1 ALWAYS LEAD

Parameter P.122 = 2

This sequence is used when it is required that pump 1 always be lead pump.

The pumps in Group 2 will be Alternated "First On First Off".

"Alternation Sequence Modifier A" (Parameter P.124) is provided to set whether or not pump 1 stays on when pumps from Group 2 are called to run.

Discrete Inputs assigned the Function of "Pump Disable" (Functions 11-16) inputs may be used to disable pumps so that they will not be called to run.

Discrete Inputs assigned the Function of "Sequence Input" (Functions 32-36) may be used to set the lead pump of Group 2.

The "Forced Lead Pump Position - Group 2" (Parameter P.130) may be used to set the lead pump.

"Time Based Alternation - Group 2" (Parameter P.132) may be setup to force alternation using an Internal Time Clock.

A Discrete Input assigned the Function of "External Alternation - Group 2" (Function 22) may be connected to an External Time Clock and used to force alternation.

A SCADA system may initiate alternation by momentarily setting Modbus Coil 96 (Register 40006, Bit 15).

Movement of Lead Pump Upon Alternation

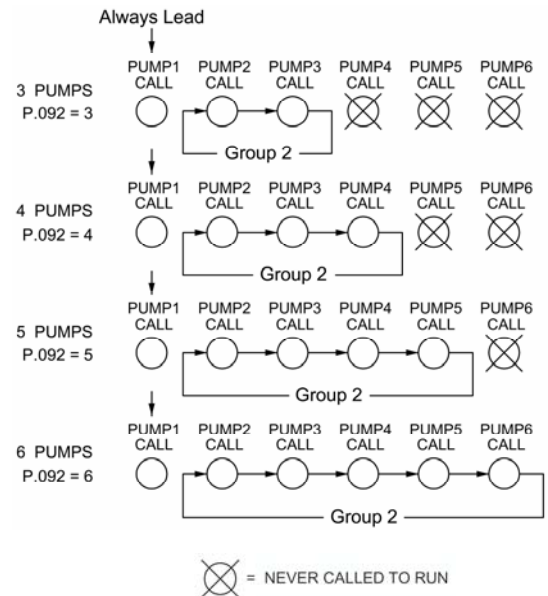

ALTERNATION SEQUENCE MODE

SPLIT ALTERNATION - 2 & 4 Parameter P.122 = 3

This sequence is used when it is required that pumps be alternated in two separate groups as shown in the adjacent diagram.

The pumps in Groups 1 and 2 will be Alternated “First On First Off”.

“Alternation Sequence Modifier A” (Parameter P.124) is provided to set whether or not pumps in Group 1 stay on when pumps from Group 2 are called to run.

Discrete Inputs assigned the Function of “Pump Disable” (Functions 11-16) inputs may be used to disable pumps so that they will not be called to run.

Discrete Inputs assigned the Function of “Sequence Input” (Functions 31-36) may be used to set the lead pump.

The “Forced Lead Pump Position - Group 1(2)” (Parameters P.129 and P.130) may be used to set the lead pump in each Group.

“Time Based Alternation - Group 1(2)” (Parameters P.131 and P.132) may be setup to force alternation using Internal Time Clocks.

A Discrete Input assigned the Function of “External Alternation - Group 1(2)” (Functions 21 and 22) may be connected to External Time Clocks and used to force alternation.

A SCADA system may initiate alternation by momentarily setting Modbus Coils 95 or 96 (Register 40006, Bit 14 or Bit 15).

Movement of Lead Pump Upon Alternation

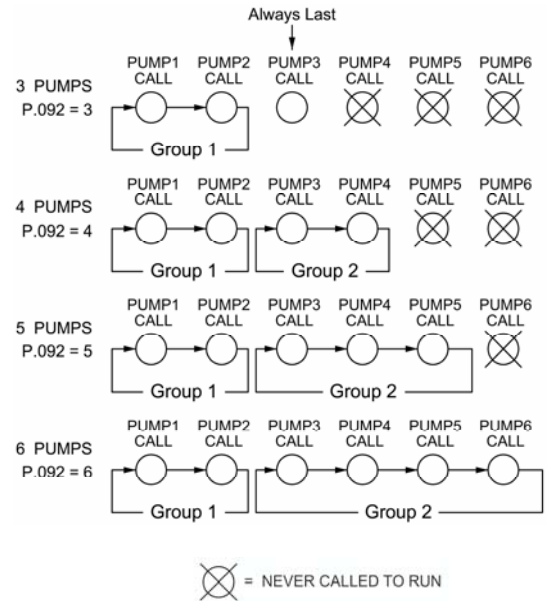

SPLIT ALTERNATION - 3 & 3 Parameter P.122 = 4

This sequence is used when it is required that pumps be alternated in two separate groups as shown in the adjacent diagram.

The pumps in Groups 1 and 2 will be Alternated “First On First Off”.

“Alternation Sequence Modifier A” (Parameter P.124) is provided to set whether or not pumps in Group 1 stay on when pumps from Group 2 are called to run.

Discrete Inputs assigned the Function of “Pump Disable” (Functions 11-16) inputs may be used to disable pumps so that they will not be called to run.

Discrete Inputs assigned the Function of “Sequence Input” (Functions 31-36) may be used to set the lead pump.

The “Forced Lead Pump Position - Group 1(2)” (Parameters P.129 and P.130) may be used to set the lead pump in each Group.

“Time Based Alternation - Group 1(2)” (Parameters P.131 and P.132) may be setup to force alternation using Internal Time Clocks.

A Discrete Input assigned the Function of “External Alternation - Group 1(2)” (Functions 21 and 22) may be connected to External Time Clocks and used to force alternation.

A SCADA system may initiate alternation by momentarily setting Modbus Coils 95 or 96 (Register 40006, Bit 14 or Bit 15).

Movement of Lead Pump Upon Alternation

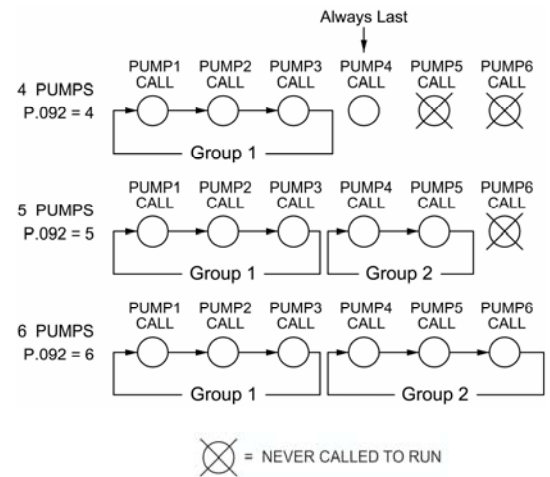

ALTERNATION SEQUENCE MODE

SPLIT ALTERNATION - 4 & 2 Parameter P.122 = 5

This sequence is used when it is required that pumps be alternated in two separate groups as shown in the adjacent diagram.

The pumps in Groups 1 and 2 will be Alternated “First On First Off”.

“Alternation Sequence Modifier A” (Parameter P.124) is provided to set whether or not pumps in Group 1 stay on when pumps from Group 2 are called to run.

Discrete Inputs assigned the Function of “Pump Disable” (Functions 11-16) inputs may be used to disable pumps so that they will not be called to run.

Discrete Inputs assigned the Function of “Sequence Input” (Functions 31-36) may be used to set the lead pump.

The “Forced Lead Pump Position - Group 1(2)” (Parameters P.129 and P.130) may be used to set the lead pump in each Group.

“Time Based Alternation - Group 1(2)” (Parameters P.131 and P.132) may be setup to force alternation using Internal Time Clocks.

A Discrete Input assigned the Function of “External Alternation - Group 1(2)” (Functions 21 and 22) may be connected to External Time Clocks and used to force alternation.

A SCADA system may initiate alternation by momentarily setting Modbus Coils 95 or 96 (Register 40006, Bit 14 or Bit 15).

Movement of Lead Pump Upon Alternation

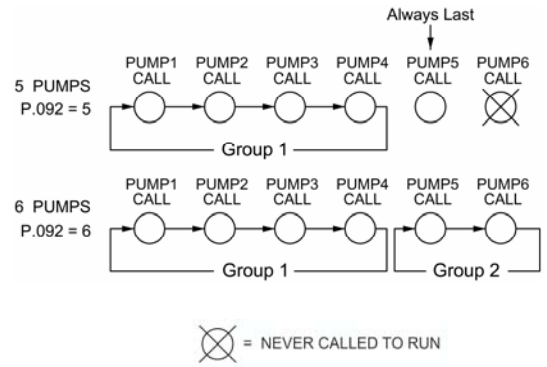

VARIABLE FREQUENCY DRIVE SPEED CONTROL OPTION SETUP

Pump Speed Versus Wet Well Level

Pump Down Application - Example Shown With All Setup Parameters Set On Their Default Values

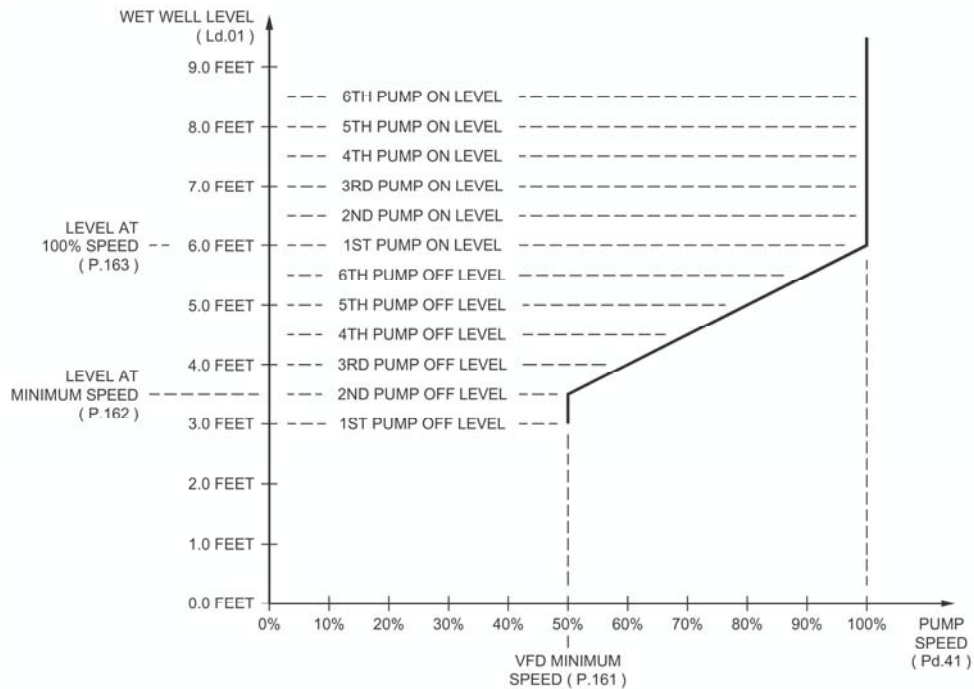

| User / Operator Info. | | | SCADA | Description of Parameters and SCADA Notes |
|----------------------------------|---------------|---------------|------------------|---|
| Parameter | Default Value | Current Value | Register Address | |
| VFD Speed Reference Setup | | | | |
| P.161 | 50% | | 40161 | VFD - Minimum Speed (Percent of Full Speed) Range: 0% - 95% |
| P.162 | 3.5 feet | | 40162 | VFD - Level at Minimum Speed Range: 0.1 - 231.0 feet |
| P.163 | 6.0 feet | | 40163 | VFD - Level at 100% Speed Range: 0.1 - 231.0 feet |
| P.164 | 0 sec. | | 40164 | Pump Start Speed Boost Time Range: 0 - 60 seconds Note: Set for 0 seconds to Disable Feature. See Note 6 below. |
| P.165 | 100% | | 40165 | VFD - Speed of Pump Under Remote Control Range: 0% - 100% |
| Pump Speed Reference Data | | | | |
| Pd.41 | - | | 41877 | Pump Speed Reference Data Range: 0.0 - 100.0 percent Note: This parameter is the Calculated Pump Speed Reference as a percent of full speed. |

Notes:

1. A drawing should be made similar to the one above in order to coordinate the Pump Call On and Off Levels with the Pump Speed Versus Level Curve.
2. For each application there is usually a Minimum Speed, below which pump operation is undesirable.
3. The Minimum Speed may be set on either the Pump Controller using Parameter P.161 or on the VFD, but not on both.
4. For cases where some pumps are operated on a VFD, and others are operated at full speed, care should be taken to setup the system so that the speed of the pumps on VFDs are not allowed to go unacceptably low while being run with the other pumps at full speed.
5. Care should be taken not to set the Level At 100% Speed parameter and the Level At Minimum Speed Parameters too close together. The Fault Indicator on the front of the controller will be turned on if these two Parameters are set too close together, or are accidentally switched around. See Fault Code 1017 on the Fault Code Table, on page F-2.
6. Pump Start Speed Boost Time - This feature causes the Speed Reference of all pumps to temporarily increase to 100% when a pump is called, and each time an additional pump is called. The pump speed stays at 100%, for the time set on the Parameter P.164. The pump speed then returns to normal. This feature may be used in cases where a pump is started at a speed that is significantly less than 100%, to ensure that the Check Valve opens.

FLUSH CYCLE

The Flush Cycle is provided to periodically flush the sludge build up from the bottom of the wet well and from the discharge pipe. This is done by periodically maximizing the lift station's discharge flow rate.

Flush Cycle Steps:

1. Upon the start of the Flush Cycle, normal pump operation is suspended (all pumps turned off).
2. It then waits for the level to rise to the "Flush Cycle Start Level" set on Parameter P.173.
3. Upon reaching the "Flush Cycle Start Level" all available pumps are turned on with a delay in between.
4. The pumps stay on until the level reaches the "Flush Cycle Stop Level" set on Parameter P.174.
5. At the "Flush Cycle Stop Level" all pumps are turned off and normal pump control resumes.

Automatically Starting Flush Cycle:

- A. Internal Time Delay - Expiration of the "Delay Between Flush Cycles" set on Parameter P.172.
- B. External Time Clock - Closure of a Discrete Input that is assigned Function 20.

Manually Starting / Stopping Flush Cycle:

- Start** - On the SC5000-CTS-HMI (Color Touchscreen HMI) - Press the "Start Cycle" pushbutton.
 On the SC5000-LED-HMI - Press & hold the LEVEL push-button until the "LEVEL" indicator starts to flash. To start the cycle through SCADA - Momentarily set Modbus Coil 90 (Register 40006 Bit 9).
- Stop** - On the SC5000-CTS-HMI - Press the "Stop Cycle" pushbutton.
 On the SC5000-LED-HMI - Press & hold the LEVEL push-button until the "LEVEL" indicator stops flashing. To stop the cycle through SCADA - Momentarily set Modbus Coil 91 (Register 40006 Bit 10).

Notes:

1. The Flush Cycle Feature only works in the "Pump Down" mode (Parameter P.149 = 1).
2. Use of an External Time Clock to start the Flush Cycle may be preferred, because it would provide control over when the Flush Cycle occurs.
3. Where VFDs are used the analog Speed Reference will be forced to 100% during the pump down.
4. The number of pumps called to run by the Flush Cycle logic is always limited by the following:
 - A. The setting on Maximum Number of Pumps Allowed to Run At the Same Time (Parameter P.093).
 - B. The closing of Discrete Inputs that are assigned as the Pump Disable inputs (Functions 11-16).
5. If the Flush Cycle is active, the closing of a Discrete Input assigned as the All Pump Disable input (Function 17), will abort the Flush Cycle.
6. All backup systems and level alarms must be setup so that they do not activate within the Flush Cycle operating range set on Parameters P.173 and P.174.
7. If the Flush Cycle is active, the closing of a Discrete Input assigned as the Pump Cutoff - Low-Low Level input (Function 59), will abort the Flush Cycle. Therefore, the Flush Cycle Stop Level must be set higher than the Low-Low Level Float Switch.

| User / Operator Info. | | | SCADA | Description of Parameters and SCADA Notes |
|---|---------------|---------------|------------------|---|
| Parameter | Default Value | Current Value | Register Address | |
| Flush Cycle Setup | | | | |
| P.171 | 0 | | 40171 | Flush Cycle Mode 0 = Flush Cycle Disabled 1 = Flush Cycle Enabled |
| P.172 | 1440 min | | 40172 | Delay Between Flush Cycles Range: 1 - 65,535 minutes |
| P.173 | 9.5 feet | | 40173 | Flush Cycle Start Level Range: 0.2 - 231.0 feet |
| P.174 | 2.5 feet | | 40174 | Flush Cycle Stop Level Range: 0.2 - 231.0 feet |
| Flush Cycle Status | | | | |
| Pd.51 | - | | 41878 | Time Remaining On Internal Time Delay minutes |
| Flush Cycle Active Status - Modbus Coil 92 (Register 40006 Bit 11). | | | | |
| Flush Cycle Active Status - Waiting For Well to Fill Up - Modbus Coil 93 (Register 40006 Bit 12). | | | | |
| Flush Cycle Active Status - Calling All Pumps to Run - Modbus Coil 94 (Register 40006 Bit 13). | | | | |

FLOW CALCULATOR

Latest Inflow Rate **65,535** gallons / minute
Parameter: Fd.01

Display Range: 0 - 65,535

Inflow Totalizer **4,294,967,295** gallons
Flow Total since the last Inflow Totalizer Reset.
Parameters: Fd.02

Display Range: 0 - 4,294,967,295

To Reset Inflow Totalizer:
Momentarily set Modbus Coil 242
(Register 40016 Bit 1).

Pump 1 - Outflow Rate **65,535** gallons / minute
Parameter: Fd.04

Display Range: 0 - 65,535

Pump 2 - Outflow Rate **65,535** gallons / minute
Parameter: Fd.05

To Reset Pump 1 - 6 Outflow Rates:
Momentarily set Modbus Coil 243
(Register 40016 Bit 2).

Pump 3 - Outflow Rate **65,535** gallons / minute
Parameter: Fd.06

Pump 4 - Outflow Rate **65,535** gallons / minute
Parameter: Fd.07

Pump 5 - Outflow Rate **65,535** gallons / minute
Parameter: Fd.08

Pump 6 - Outflow Rate **65,535** gallons / minute
Parameter: Fd.09

Average Daily Inflow Total **4,294,967,295** gallons / day
Flow Totals from the Last 7 days Averaged Together.
Parameters: Fd.10

Display Range: 0 - 4,294,967,295

Data Used to Calculate the **Average Daily Inflow Total**

Daily Inflow Totals gallons / day

Current Day

4,294,967,295

Parameters: Fd.12

Day 1

4,294,967,295

Day 2

4,294,967,295

Day 3

4,294,967,295

Day 4

4,294,967,295

Day 5

4,294,967,295

Day 6

4,294,967,295

Day 7

4,294,967,295

Parameters:

Fd.14

Fd.16

Fd.18

Fd.20

Fd.22

Fd.24

Fd.26

Newest Complete Day's Data

Display Range: 0 - 4,294,967,295

Oldest Complete Day's Data

FLOW CALCULATOR SETUP

| User / Operator Info. | | SCADA | | Description of Parameters and SCADA Notes |
|------------------------------|------------------|---------------|------------------|---|
| Parameter | Default Value | Current Value | Register Address | |
| Flow Calculator Setup | | | | |
| P.175 | 0 | | 40175 | <p>Flow Calculator Mode</p> <p>0 = Flow Calculator Disabled - All Flow Data is Reset to Zero 1 = Flow Calculator Enabled - Internal Time Clock 2 = Flow Calculator Enabled - External Time Clock</p> <p>Note: When an External Time Clock is used (Parameter P.175 = 2), the "Start New Day" command must be signaled once each day by closing a Discrete Input assigned to "Start New Day" Function 47, or by momentarily setting Modbus Coil 241 (Register 40016 Bit 0).</p> |
| P.176 | 79.0 Square Feet | | 40176 | <p>Surface Area of Wet Well Range: 2.0 - 2,000.0 Square Feet</p> <p>Note: See "Surface Area Calculation" on page 1-23.</p> |
| P.177 | 20 Minutes | | 40177 | <p>Delay Before Forcing On Additional Pump(s)</p> <p style="text-align: right;">Range: 4 - 60 Minutes</p> <p>Note: The "Latest Inflow Rate" can only be updated while all pumps are off, so the station must periodically pump all the way down, and turn off all pumps. Parameter P.177 is provided to set the "Delay Before Forcing On Additional Pump(s)". When this delay expires an additional pump or pumps are called to run, and the wet well is pumped down. After calling the first additional pump, there is a 4 minute delay before another is called.</p> |
| P.178 | 20 Minutes | | 40178 | <p>Latest Inflow Rate Reset Delay Range: 1 - 100 Minutes</p> <p>Note: The "Latest Inflow Rate" can only be updated while the level is rising, so in cases where the flow into the station drops from a significant amount of inflow to near zero inflow, the Flow Calculator will be left with a "Latest Inflow Rate" that is too high. To prevent the Flow Totalizer from continuing to operate with an invalid "Latest Inflow Rate", logic is provided to reset the "Latest Inflow Rate" to zero when the delay set on this parameter expires.</p> <p>Parameter P.178 must be set for the longest time expected (under low flow conditions), that it will take for the level to rise 0.5 foot when a Pressure Transducer is used for level measurement, or the distance between electrodes when a Level Probe is used.</p> |

Notes:

- In order for the Flow Calculator to measure the Latest Inflow Rate the lift station must regularly pump down and turn off all pumps. Using the delay setting on Parameter P.177 the Flow Calculator will automatically bring on additional pumps, pump down the wet well and turn off all pumps so that it can measure the Latest Inflow Rate.
- The Flow Calculator requires the following setting to operate:
 - The "Master Control Mode" must be set for "Level Control", (Parameter P.091 = 1).
 - The "Pump Up or Down Mode" must be set for "Pump Down - Empty a Tank", (Parameter P.149 = 1).
 - The "Level Input Source" must be set for one of the following:
 - "Analog Level Meter" (Parameter P.133 = 1, 2, 3, or 4)
 - "Level Probe Meter" (Parameter P.133 = 5)
- The "Average Daily Flow Total" is not valid until after 7 days of operation with Parameter P.175 = 1, or 2.
- All flow data is erased when Parameter P.175 is set to "0".
- While in the process of updating the "Latest Inflow Rate", if the level rises too fast, the logic will abort the measurement and keeps the previously determined value. It is considered too fast if the rise rate produces a "Latest Inflow Rate" of more than 65,535 gallons / minute. If this occurs the "Level Rising Too Fast" status is set for 10 seconds, then cleared. The "Level Rising Too Fast" status may be viewed from Modbus Coil 244 (Register 40016 Bit 3).

FLOW CALCULATOR DATA

Latest Inflow Rate - The Most Recently Determined Flow Rate into the Lift Station

The Flow Calculator determines the "Latest Inflow Rate" of liquid flowing into the lift station by observing how long it takes for the wet well level to rise a "known distance", while all pumps are off. Knowing the surface area of the wet well (Parameter P.176), the volume of liquid per minute flowing into the wet well is calculated. The "known distance" used in the calculation is a change in level of 0.5 foot when an Analog Level Input is used (Level Input Source: Parameter P.133 = 1, 2, 3, or 4), or the distance between electrodes (Parameter P.520) when using Level Probe Inputs (Level Input Source: Parameter P.133 = 5). The "Latest Inflow Rate", in gallons / minute, may be viewed from Parameter Fd.01.

Inflow Totalizer - The Inflow Total since the last "Inflow Totalizer Reset"

The Flow Calculator keeps a running total of how much liquid flows into the lift station, since the last "Inflow Totalizer Reset", which resets the totalizer to zero. The Inflow Totalizer value must be read and recorded at some consistent interval (daily, weekly, monthly) and then reset back to zero. The Inflow Totalizer value is in gallons and may be viewed from Parameters Fd.02. To reset the Inflow Totalizer momentarily set Modbus Coil 242 (Register 40016 Bit 1).

Pump 1 - 6 Outflow Rate - The Most Recently Determined Outflow Rate of Each Pump

The Flow Calculator also determines and updates the "Pump Outflow Rate" of each pump whenever it completes a pumping cycle by itself. This is done by first calculating the volume of liquid in the wet well between the level where the pump was turned on and where it was turned off, and then adding to it what had flowed into the wet well while the pump was running ("Latest Inflow Rate" multiplied by the "Pump Run Cycle Time"). This total volume of liquid is then divided by the "Pump Run Cycle Time" to arrive at the "Pump Outflow Rate". The most recent "Pump Outflow Rate" of each pump in gallons / minute, may be viewed from Parameters Fd.04 - Fd.09. To Reset to zero momentarily set Modbus Coil 243 (Register 40016 Bit 2).

Average Daily Inflow Total - The Inflow Totals from the Last 7 days Averaged Together

The Flow Calculator uses the "Latest Inflow Rate" to keep a running total of how much liquid flows into the lift station during a 24 hour period. This is done for each 24 hour period. The flow totals from the previous 7 days are all kept stored. These flow totals are added together and divided by 7. The "Average Daily Inflow Total", in gallons / day may be viewed from Parameters Fd.10.

| Parameter | Register Address | Data Description | |
|--|------------------|--|--|
| Flow Calculator - Latest Inflow Rate | | | |
| Fd.01 | 42101 | Flow Calculator - Latest Inflow Rate (gallons / minute) | Display Range: 0 - 65,535 |
| Flow Calculator - Inflow Totalizer | | | |
| Fd.02 | 42102 | Least Significant of 32-Bit Number | Flow Calculator - Inflow Totalizer (gallons) Display Range: 0 - 4,294,967,295 |
| | 42103 | Most Significant of 32-Bit Number | |
| Inflow Totalizer Reset - To Reset Inflow Totalizer to zero momentarily set Modbus Coil 242 (Register 40016 Bit 1). | | | |
| Flow Calculator - Pump 1 - 6 Outflow Rate | | | |
| Fd.04 | 42104 | Flow Calculator - Pump 1 Outflow Rate (gallons / minute) | Display Range: 0 - 65,535 |
| Fd.05 | 42105 | Flow Calculator - Pump 2 Outflow Rate (gallons / minute) | Display Range: 0 - 65,535 |
| Fd.06 | 42106 | Flow Calculator - Pump 3 Outflow Rate (gallons / minute) | Display Range: 0 - 65,535 |
| Fd.07 | 42107 | Flow Calculator - Pump 4 Outflow Rate (gallons / minute) | Display Range: 0 - 65,535 |
| Fd.08 | 42108 | Flow Calculator - Pump 5 Outflow Rate (gallons / minute) | Display Range: 0 - 65,535 |
| Fd.09 | 42109 | Flow Calculator - Pump 6 Outflow Rate (gallons / minute) | Display Range: 0 - 65,535 |
| Pump Data Reset - To Reset Pump 1 - 6 Outflow Rate to zero momentarily set Modbus Coil 243 (Register 40016 Bit 2). | | | |
| Flow Calculator - Average Daily Inflow Total | | | |
| Fd.10 | 42110 | Least Significant of 32-Bit Number | Flow Calculator - Average Daily Inflow Total (gallons) Display Range: 0 - 4,294,967,295 |
| | 42111 | Most Significant of 32-Bit Number | |

FLOW CALCULATOR DATA

Daily Inflow Total - Current Day

This is inflow data that is currently being collected. It is the total of the inflow that has been collected, since the last “Start New Day” command. Upon receiving the “Start New Day” command, the Flow Calculator will move the value into “Daily Inflow Total - Day 1”, reset itself back to zero, and then start collecting inflow data for the next 24 hour period. It may be viewed in gallons from Parameter Fd.12.

Daily Inflow Totals - Day 1 - 7

Each of the Daily Inflow Totals are the total of the inflow that was collected during a 24 hour period one day in the previous week. Upon receiving the “Start New Day” command signal, the Flow Calculator will move all of the values down one position in the data table shown below. The oldest day’s data is discarded. The values may be viewed in gallons / day from the Parameters shown below.

| Parameter | Register Address | | Data Description |
|---|------------------|------------------------------------|---|
| Flow Calculator - Daily Inflow Total - Current Day | | | |
| Fd.12 | 42112 | Least Significant of 32-Bit Number | Flow Calculator - Daily Inflow Total - Current Day (gallons) |
| | 42113 | Most Significant of 32-Bit Number | Collects Current Day’s Data Display Range: 0 - 4,294,967,295 |
| Flow Calculator - Daily Inflow Totals - Day 1 - 7 | | | |
| Fd.14 | 42114 | Least Significant of 32-Bit Number | Flow Calculator - Daily Inflow Total - Day 1 (gallons / day) |
| | 42115 | Most Significant of 32-Bit Number | Newest Complete Day’s Data Display Range: 0 - 4,294,967,295 |
| Fd.16 | 42116 | Least Significant of 32-Bit Number | Flow Calculator - Daily Inflow Total - Day 2 (gallons / day) |
| | 42117 | Most Significant of 32-Bit Number | Display Range: 0 - 4,294,967,295 |
| Fd.18 | 42118 | Least Significant of 32-Bit Number | Flow Calculator - Daily Inflow Total - Day 3 (gallons / day) |
| | 42119 | Most Significant of 32-Bit Number | Display Range: 0 - 4,294,967,295 |
| Fd.20 | 42120 | Least Significant of 32-Bit Number | Flow Calculator - Daily Inflow Total - Day 4 (gallons / day) |
| | 42121 | Most Significant of 32-Bit Number | Display Range: 0 - 4,294,967,295 |
| Fd.22 | 42122 | Least Significant of 32-Bit Number | Flow Calculator - Daily Inflow Total - Day 5 (gallons / day) |
| | 42123 | Most Significant of 32-Bit Number | Display Range: 0 - 4,294,967,295 |
| Fd.24 | 42124 | Least Significant of 32-Bit Number | Flow Calculator - Daily Inflow Total - Day 6 (gallons / day) |
| | 42125 | Most Significant of 32-Bit Number | Display Range: 0 - 4,294,967,295 |
| Fd.26 | 42126 | Least Significant of 32-Bit Number | Flow Calculator - Daily Inflow Total - Day 7 (gallons / day) |
| | 42127 | Most Significant of 32-Bit Number | Oldest Complete Day’s Data Display Range: 0 - 4,294,967,295 |

FLOW CALCULATOR DATA

Pump 1 - 6 Run Cycle Time

This is the most recently determined pump run time of a respective pump, while it is running by itself. This is done by determining how long it takes to pump down from the “1st On Level” to the “1st Off Level”. This information is used in the calculation of the “Pump Outflow Rate”. The most recent “Pump Run Cycle Time” of each pump may be viewed in minutes from Parameters Fd.28 - Fd.33. To Reset to zero momentarily set Modbus Coil 243 (Register 40016 Bit 2).

Internal Time Clock - Hours and Minutes Elapsed Since the Start of a New Day

This clock keeps track of how much time has elapsed since the last signal to a “Start New Day”. The time may be viewed from Parameters Fd.34 and Fd.35.

With the Flow Calculator Mode (Parameter P.175) = 1, the Internal Time Clock will run and the signal to “Start New Day” will be automatically issued when it gets to 24 hours, the Time Clock is also reset to zero at that time.

With the Flow Calculator Mode (Parameter P.175) = 2, the Internal Time Clock will run, but not issue the “Start New Day” signal. The signal to “Start New Day” must be initiated externally, once each day by an External Time Clock by one of the following ways:

1. By using an External Time Clock to close a Discrete Input programmed for the “Start New Day”, Function 47. The Internal Time Clock will also be reset to zero.
2. By programming the SCADA system to send the signal to “Start New Day” by momentarily setting Modbus Coil 241 (Register 40016 Bit 0). The Internal Time Clock will also be reset to zero.

Time Measuring the Latest Inflow Rate

This is the time it takes for the wet well to rise 0.5 foot using the Analog Level Input (Parameter P.133 = 1, 2, 3, or 4) or if Level Probe Inputs are used for the Level Input (Parameter P.133 = 5), then it is the time it takes for the wet well to rise 1 Electrode spacing. It may be viewed in minutes from Parameters Fd.36.

| Parameter | Register Address | Data Description | |
|--|------------------|---|------------------------------|
| Flow Calculator - Pump 1 - 6 Run Cycle Time | | | |
| Fd.28 | 42128 | Flow Calculator - Pump 1 Run Cycle Time (minutes) | Display Range: 0.00 - 655.35 |
| Fd.29 | 42129 | Flow Calculator - Pump 2 Run Cycle Time (minutes) | Display Range: 0.00 - 655.35 |
| Fd.30 | 42130 | Flow Calculator - Pump 3 Run Cycle Time (minutes) | Display Range: 0.00 - 655.35 |
| Fd.31 | 42131 | Flow Calculator - Pump 4 Run Cycle Time (minutes) | Display Range: 0.00 - 655.35 |
| Fd.32 | 42132 | Flow Calculator - Pump 5 Run Cycle Time (minutes) | Display Range: 0.00 - 655.35 |
| Fd.33 | 42133 | Flow Calculator - Pump 6 Run Cycle Time (minutes) | Display Range: 0.00 - 655.35 |
| Pump Data Reset - To Reset Pump 1 - 6 Run Cycle Time to zero momentarily set Modbus Coil 243 (Register 40016 Bit 2). | | | |
| Flow Calculator - Internal Time Clock | | | |
| Fd.34 | 42134 | Flow Calculator - Internal Time Clock - Minutes Since the Start of a New Day The time (minutes) elapsed since the signal to “Start New Day” Also see: Parameter Fd.35 | Display Range: 0 - 60 |
| Fd.35 | 42135 | Flow Calculator - Internal Time Clock - Hours Since the Start of a New Day The time (hours) elapsed since the signal to “Start New Day” Also see: Parameter Fd.34 | Display Range: 0 - 65535 |
| Flow Calculator - Time Measuring the Latest Inflow Rate | | | |
| Fd.36 | 42136 | Flow Calculator - Time Measuring the Latest Inflow Rate (minutes) | Display Range: 0.00 - 655.35 |

FLOW CALCULATOR - Surface Area Calculation

Rectangular Wet Well

Area = Length x Width Where Length & Width Measurements are in: Feet

Circular Wet Well

Area = $\pi \left[\frac{1}{2} \text{Diameter} \right]^2$ Where Diameter is in: Feet

Area = 3.14159 x 1/2 Diameter x 1/2 Diameter

$\pi = 3.14159$

LEVEL CONTROL EXAMPLE - ANALOG LEVEL INPUT

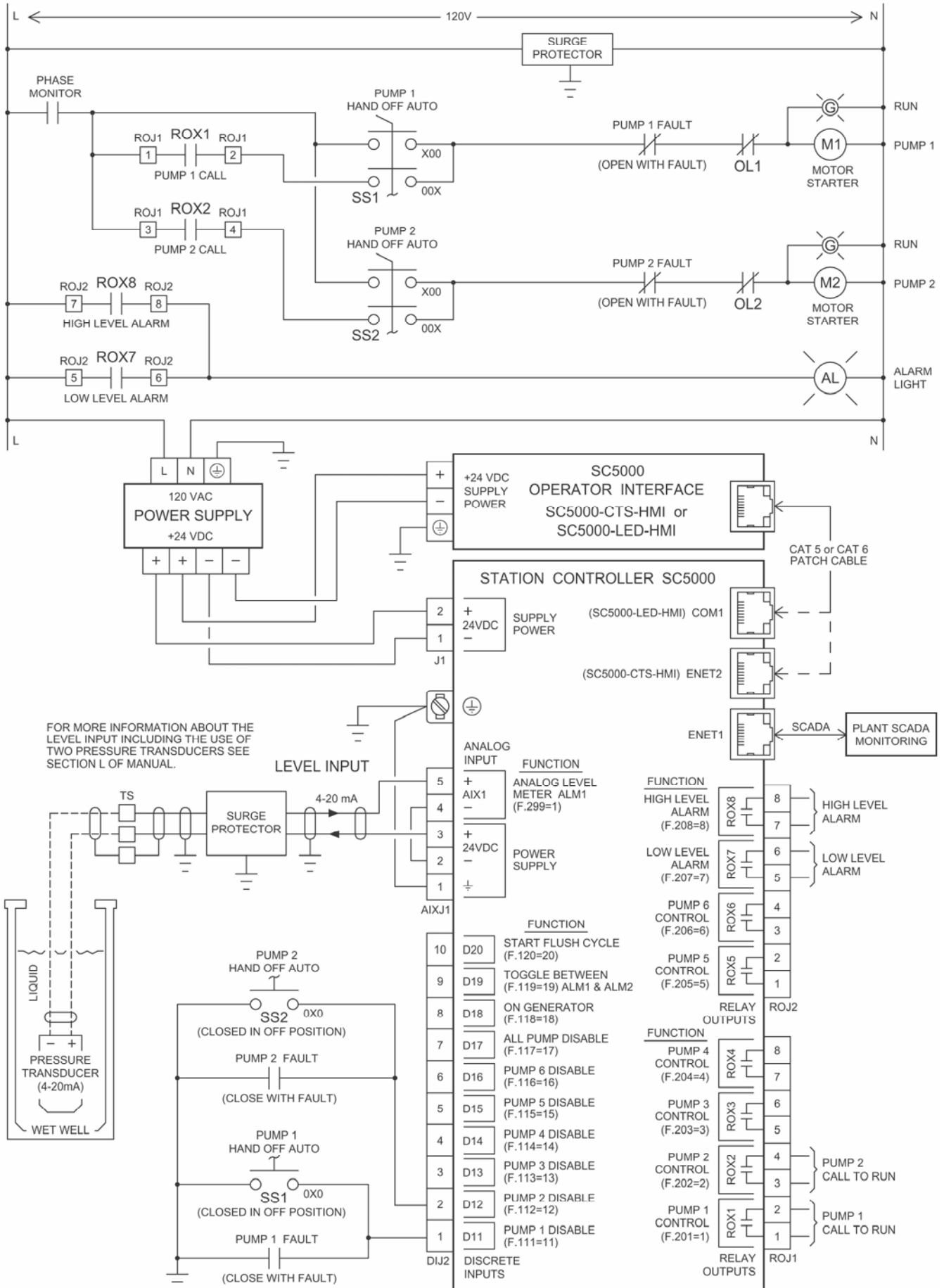

LEVEL CONTROL EXAMPLE - ANALOG LEVEL INPUT - With VFDs

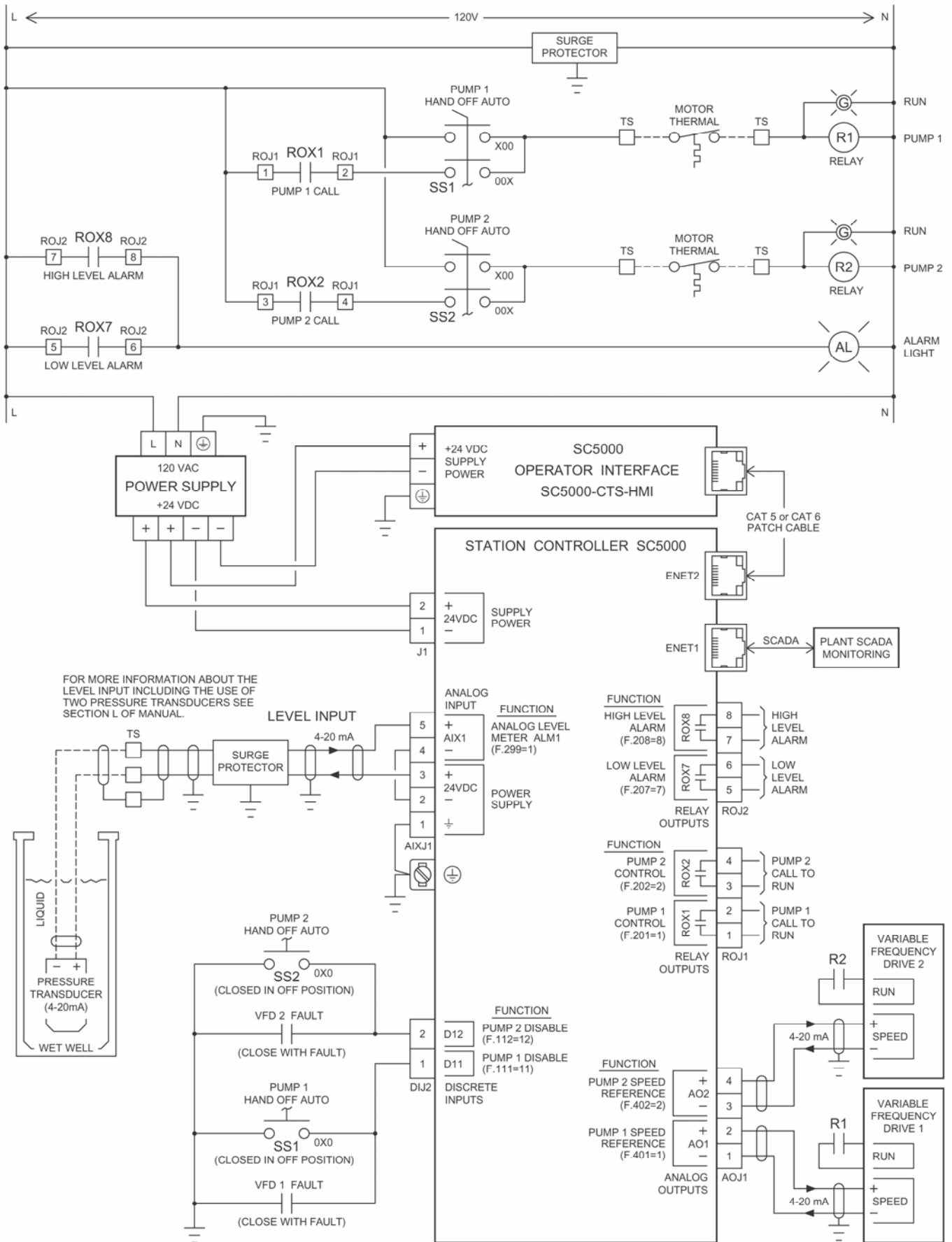

LEVEL CONTROL EXAMPLE - LEVEL PROBE INPUT

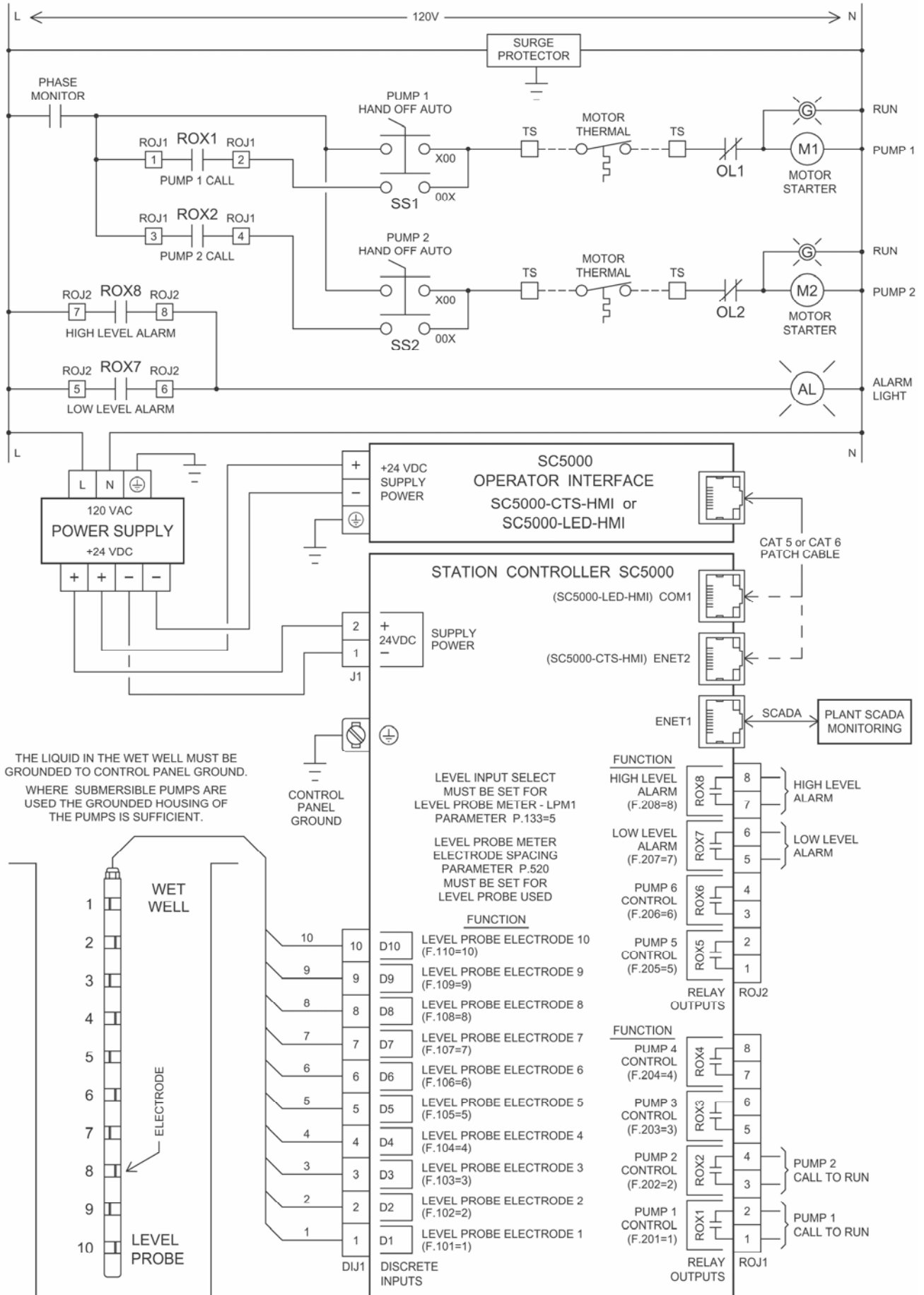

LEVEL CONTROL EXAMPLE - FLOAT CONTROL - PUMP DOWN

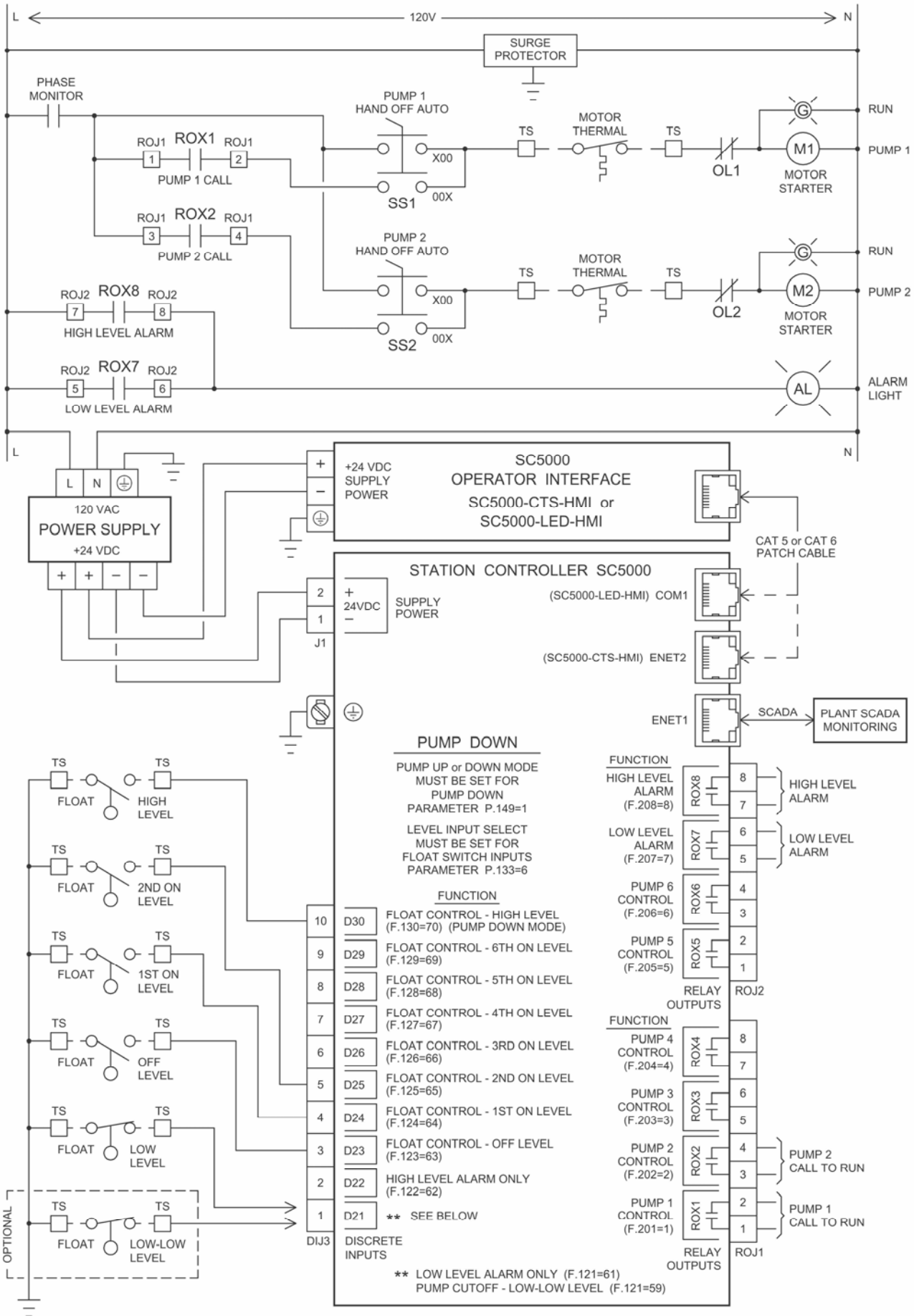

LEVEL CONTROL EXAMPLE - FLOAT CONTROL - PUMP UP

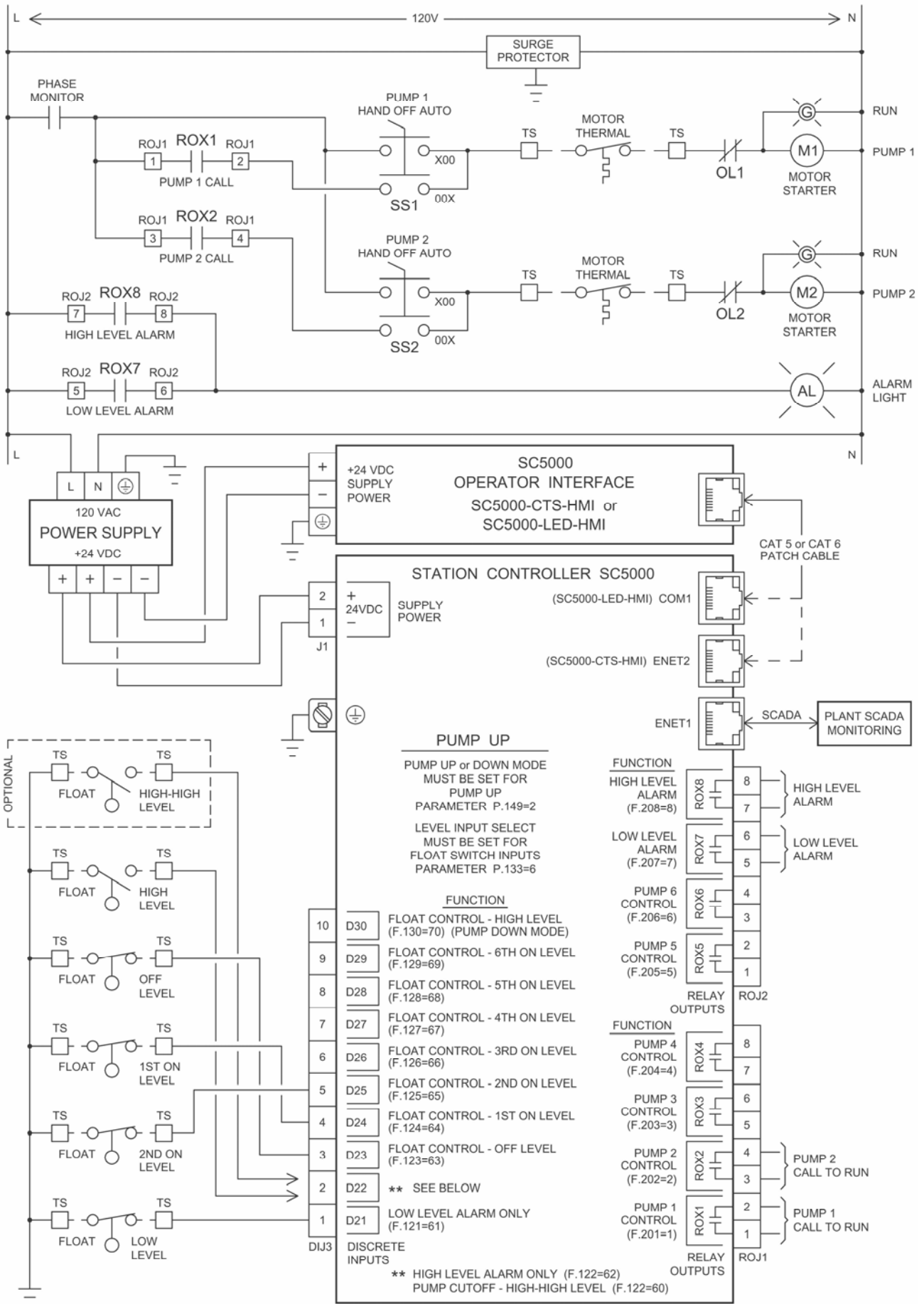

FLOAT BACKUP EXAMPLE - PUMP DOWN

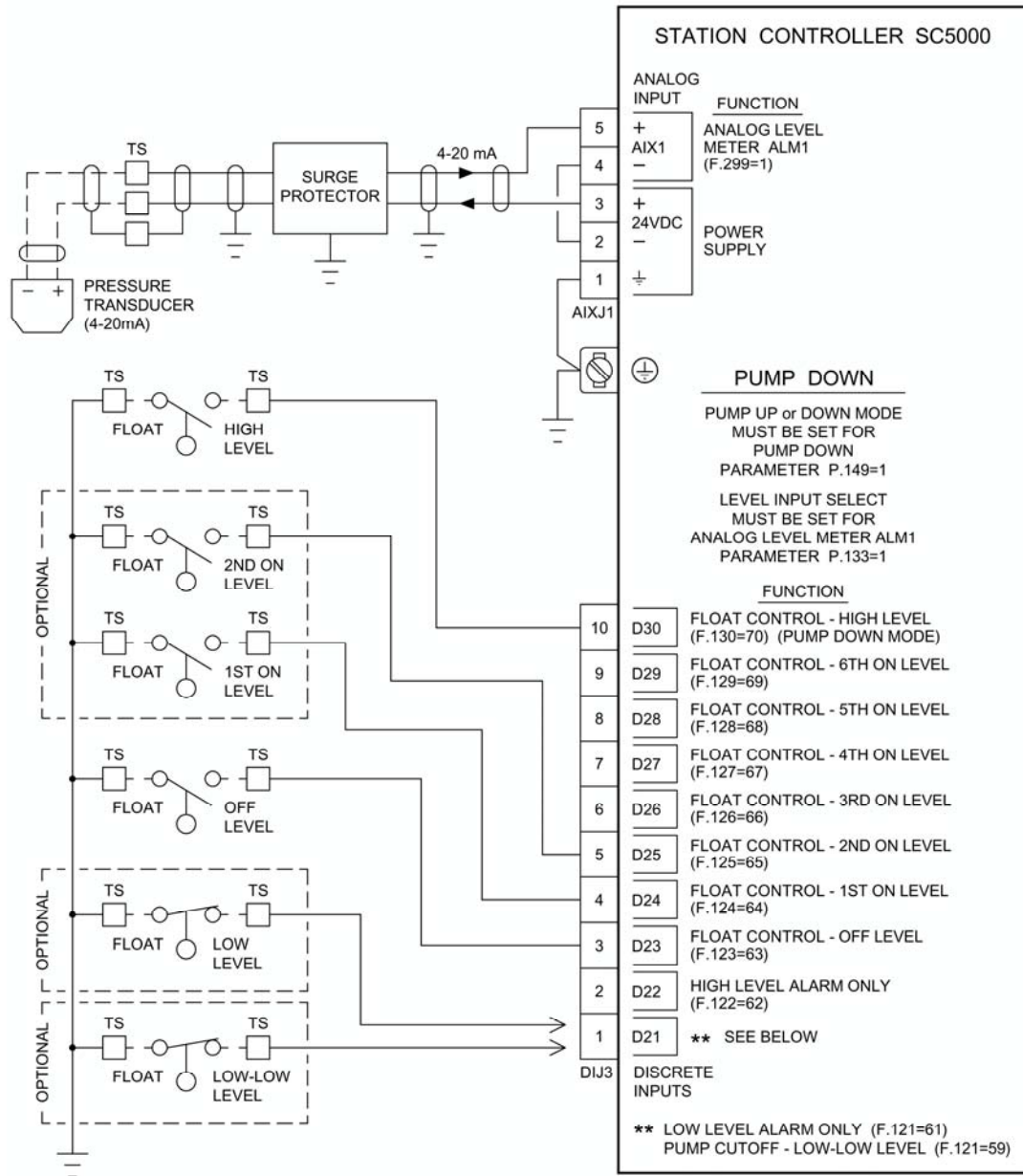

Notes:

This example shows a Pump Down Application (Parameter P.149 = 1) where an Analog Level Input is the primary level input for level control and where two or more Discrete Inputs are connected to floats and used for backup pump control.

A simple two float backup system can be made using a "Float Control - Off Level" (Function 63) and a "Float Control - High Level" (Function 70).

High Level input

For Float Control of the pumps upon High Level - Assign the High Level Float Input to "Float Control - High Level" (Function 70). Upon closure all available pumps will be called to run, provided the Off Level float input is closed.

For Alarm Only - A High Level Float Input may be assigned to "High Level Alarm Only" (Function 62). This Function is not recommended because it only activates the High Level Alarm and does not provide backup control of the pumps.

Low Level input

For Pump Cutoff upon Low-Low Level - Assign the Discrete Input to "Pump Cutoff - Low-Low Level" (Function 59). Upon closure all pump operation will be disabled. When the Low-Low Level Float input opens, a delay prevents the immediate calling of the pumps. This delay is set on Parameter P.153.

For Alarm Only - Assign the Discrete Input to "Low Level Alarm Only" (Function 61).

Float Type - For Pump Down applications the Off, 1st, 2nd, 3rd, 4th, 5th, 6th On, and High floats must be Normally Open float switches that close as the level rises above the float. The Low Level or Low-Low Level float must be a Normally Closed float that opens as the level rises above the float.

The FAULT light comes on and Fault Code 1050 is generated, when a pump is called to run by the Float Backup system.

FLOAT BACKUP EXAMPLE - PUMP UP

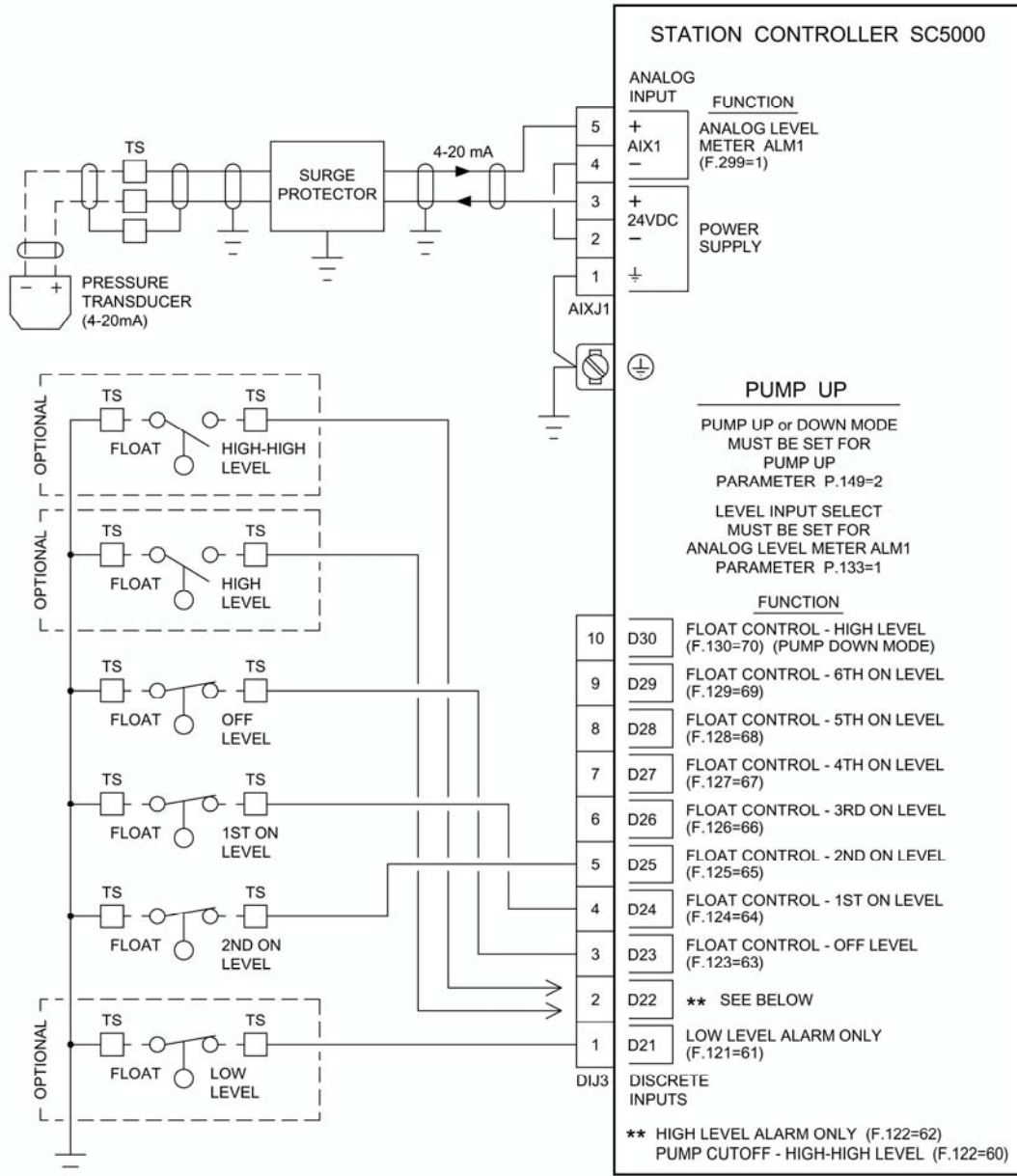

Notes:

This example shows a Pump Up Application (Parameter P.149 = 2) where an Analog Level Input is the primary level input for level control and where three or more Discrete Inputs are connected to floats and used for backup pump control.

High Level input

For Pump Cutoff upon High-High Level - Assign the Discrete Input to "Pump Cutoff - High-High Level" (Function 60). Upon closure all pump operation will be disabled. When the High-High Level Float input opens, a delay prevents the immediate calling of the pumps. This delay is set on Parameter P.154.

For Alarm Only - A High Level Float Input may be assigned to "High Level Alarm Only" (Function 62). This Function only activates the High Level Alarm and does not provide Pump Cutoff.

Low Level input

For Alarm Only - Assign the Discrete Input to "Low Level Alarm Only" (Function 61). This Function only activates the Low Level Alarm.

Float Type - For Pump Up applications the Off, 1st, 2nd, 3rd, 4th, 5th, 6th On, and Low float must be Normally Closed float switches that open as the level rises above the float. The High Level or High-High Level float must be a Normally Open float that closes as the level rises above the float.

The FAULT light comes on and Fault Code 1050 is generated, when a pump is called to run by the Float Backup system.

LEVEL CONTROL - Touchscreen HMI SCREENS

Main Screen

STATION CONTROLLER SC5000

| | | |
|---|---|---|
| <p>Fault Code</p> <p>FLC 1234</p> <p>LFC 1234</p> <p>Reset</p> | <p>Control Mode Select</p> <p>Pump Setup</p> <p>Security Setup</p> <p>SCADA Setup</p> <p>Backup / Restore</p> | <p>Parameter Security</p> <p>PARAMETERS UNLOCKED</p> <p>Security Code Entry</p> |
| <p>I / O</p> <p>Discrete Inputs</p> <p>Relay Outputs</p> <p>Analog Inputs</p> <p>Analog Outputs</p> | <p>Meters</p> <p>Level</p> <p>Pressure</p> <p>Flow</p> <p>Current</p> | <p>Station Status & Setup</p> |

Control Mode Select

Previous Screen

CONTROL MODE SELECT

Master Control Mode

| | |
|---|--|
| 1 | 1 = Level Control 2 = Flow Control 3 = Pressure Control 4 = Booster Discharge Pressure Control 5 = Booster Supply Pressure Control |
|---|--|

LEVEL CONTROL - Touchscreen HMI SCREENS

Pump Setup

PUMP SETUP

[Previous Screen](#)

Number of Pumps Present

1

Parameter: P.092

Maximum Number of Pumps Allowed To Run At The Same Time

1

Parameter: P.093

Maximum Number of Pumps Allowed To Run While On Generator

1

(See Discrete Input Function 18) Parameter: P.094

Level Control Main Screen

SC5000 LEVEL CONTROLMain Screen

Fault Code

FLC 1234

LFC 1234

Reset

Level Setpoints

Float Backup

VFD Control

Flush Cycle

Flow Calculator

Pump Status

Parameter Security

PARAMETERS UNLOCKED

Security Code Entry

Level Input Select

Control Setup

Pump Alternation

Controller Info.

Station Status

LEVEL CONTROL - Touchscreen HMI SCREENS

Station Status - Analog Level Input - 1 Pump

LEVEL - ALM1

High Alarm

Low Alarm

123.4 feet

Push To Start Level Simulation

Pump 1
Not Available For Service
OFF
DISABLE FORCE
1234.5
ETM (hours)

| | |
|----------------------------------|------------------------------------|
| High Level Pump Cutoff Active | All Pump Disable Active |
| Flush Cycle Active | Float Backup Control Active |
| Low-Low Level Pump Cutoff Active | Flow Calculator Forcing On Pump(s) |

FAULT CODE

FLC 1234

LFC 1234

RESET

Previous Screen

Station Status - Analog Level Input - 2 Pumps

LEVEL - ALM1

High Alarm

Low Alarm

123.4 feet

Push To Start Level Simulation

Pump 1
Not Available For Service
OFF
DISABLE FORCE
1234.5
ETM (hours)

Pump 2
Not Available For Service
OFF
DISABLE FORCE
1234.5
ETM (hours)

| | |
|----------------------------------|------------------------------------|
| High Level Pump Cutoff Active | All Pump Disable Active |
| Flush Cycle Active | Float Backup Control Active |
| Low-Low Level Pump Cutoff Active | Flow Calculator Forcing On Pump(s) |

FAULT CODE

FLC 1234

LFC 1234

RESET

Previous Screen

LEVEL CONTROL - Touchscreen HMI SCREENS

Station Status - Analog Level Input - 3 Pumps

LEVEL - ALM1 Previous Screen

High Alarm

Low Alarm

123.4 feet

Push To Start Level Simulation

| | | |
|---------------------------|---------------------------|---------------------------|
| Pump 1 | Pump 2 | Pump 3 |
| Not Available For Service | Not Available For Service | Not Available For Service |
| OFF | OFF | OFF |
| DISABLE FORCE | DISABLE FORCE | DISABLE FORCE |
| 1234.5 | 1234.5 | 1234.5 |
| ETM (hours) | ETM (hours) | ETM (hours) |

| | | |
|----------------------------------|------------------------------------|--|
| High Level Pump Cutoff Active | All Pump Disable Active | |
| Flush Cycle Active | Float Backup Control Active | |
| Low-Low Level Pump Cutoff Active | Flow Calculator Forcing On Pump(s) | |

FAULT CODE

FLC 1234 RESET

LFC 1234 RESET

Station Status - Analog Level Input - 4 Pumps

LEVEL - ALM1 Previous Screen

High Alarm

Low Alarm

123.4 feet

Push To Start Level Simulation

| | | | |
|---------------------------|---------------------------|---------------------------|---------------------------|
| PUMP 1 | PUMP 2 | PUMP 3 | PUMP 4 |
| Not Available For Service | Not Available For Service | Not Available For Service | Not Available For Service |
| OFF | OFF | OFF | OFF |
| DISABLE | DISABLE | DISABLE | DISABLE |
| FORCE | FORCE | FORCE | FORCE |
| 1234.5 | 1234.5 | 1234.5 | 1234.5 |
| ETM (hours) | ETM (hours) | ETM (hours) | ETM (hours) |

| | | | |
|----------------------------------|------------------------------------|--|--|
| High Level Pump Cutoff Active | All Pump Disable Active | | |
| Flush Cycle Active | Float Backup Control Active | | |
| Low-Low Level Pump Cutoff Active | Flow Calculator Forcing On Pump(s) | | |

FAULT CODE

FLC 1234 RESET

LFC 1234 RESET

LEVEL CONTROL - Touchscreen HMI SCREENS

Station Status - Analog Level Input - 5 Pumps

LEVEL - ALM1
Previous Screen

High Alarm

Low Alarm

123.4

feet

Push To Start Level Simulation

| PUMP 1 | PUMP 2 | PUMP 3 | PUMP 4 | PUMP 5 |
|---------------------------|---------------------------|---------------------------|---------------------------|---------------------------|
| Not Available For Service | Not Available For Service | Not Available For Service | Not Available For Service | Not Available For Service |
| OFF | OFF | OFF | OFF | OFF |
| DISABLE | DISABLE | DISABLE | DISABLE | DISABLE |
| FORCE | FORCE | FORCE | FORCE | FORCE |
| 1234.5 | 1234.5 | 1234.5 | 1234.5 | 1234.5 |
| ETM (hours) | ETM (hours) | ETM (hours) | ETM (hours) | ETM (hours) |

High Level Pump Cutoff Active

Flush Cycle Active

Low-Low Level Pump Cutoff Active

All Pump Disable Active

Float Backup Control Active

Flow Calculator Forcing On Pump(s)

FAULT CODE

FLC 1234

LFC 1234

RESET

Station Status - Analog Level Input - 6 Pumps

LEVEL - ALM1
Previous Screen

High Alarm

Low Alarm

123.4

feet

Push To Start Level Simulation

| PUMP 1 | PUMP 2 | PUMP 3 | PUMP 4 | PUMP 5 | PUMP 6 |
|---------------------------|---------------------------|---------------------------|---------------------------|---------------------------|---------------------------|
| Not Available For Service | Not Available For Service | Not Available For Service | Not Available For Service | Not Available For Service | Not Available For Service |
| OFF | OFF | OFF | OFF | OFF | OFF |
| DISABLE | DISABLE | DISABLE | DISABLE | DISABLE | DISABLE |
| FORCE | FORCE | FORCE | FORCE | FORCE | FORCE |
| 1234.5 | 1234.5 | 1234.5 | 1234.5 | 1234.5 | 1234.5 |
| ETM (hours) | ETM (hours) | ETM (hours) | ETM (hours) | ETM (hours) | ETM (hours) |

High Level Pump Cutoff Active

Flush Cycle Active

Low-Low Level Pump Cutoff Active

All Pump Disable Active

Float Backup Control Active

Flow Calculator Forcing On Pump(s)

FAULT CODE

FLC 1234

LFC 1234

RESET

LEVEL CONTROL - Touchscreen HMI SCREENS

Station Status - Level Probe Input - 1 Pump

HIGH ALARM

LEVEL PROBE STATUS

Electrode 1
Electrode 2
Electrode 3
Electrode 4
Electrode 5
Electrode 6
Electrode 7
Electrode 8
Electrode 9
Electrode 10

LOW ALARM

123.4 feet

PUSH TO START LEVEL SIMULATION

DN UP

Pump 1
Not Available For Service
OFF
DISABLE FORCE
1234.5
ETM (hours)

High Level Pump Cutoff Active
All Pump Disable Active
Electrode Out of Sequence
Flush Cycle Active
Low-Low Level Pump Cutoff Active
Flow Calculator Forcing On Pump(s)

Previous Screen

FAULT CODE
FLC 1234
LFC 1234
RESET

Station Status - Level Probe Input - 2 Pumps

HIGH ALARM

LEVEL PROBE STATUS

Electrode 1
Electrode 2
Electrode 3
Electrode 4
Electrode 5
Electrode 6
Electrode 7
Electrode 8
Electrode 9
Electrode 10

LOW ALARM

123.4 feet

PUSH TO START LEVEL SIMULATION

DN UP

Pump 1
Not Available For Service
OFF
DISABLE FORCE
1234.5
ETM (hours)

Pump 2
Not Available For Service
OFF
DISABLE FORCE
1234.5
ETM (hours)

High Level Pump Cutoff Active
All Pump Disable Active
Electrode Out of Sequence
Flush Cycle Active
Low-Low Level Pump Cutoff Active
Flow Calculator Forcing On Pump(s)

Previous Screen

FAULT CODE
FLC 1234
LFC 1234
RESET

LEVEL CONTROL - Touchscreen HMI SCREENS

Station Status - Level Probe Input - 3 Pumps

HIGH ALARM

LEVEL PROBE STATUS

Electrode 1
Electrode 2
Electrode 3
Electrode 4
Electrode 5
Electrode 6
Electrode 7
Electrode 8
Electrode 9
Electrode 10

PUMP 1
Not Available For Service
OFF
DISABLE FORCE
1234.5
ETM (hours)

PUMP 2
Not Available For Service
OFF
DISABLE FORCE
1234.5
ETM (hours)

PUMP 3
Not Available For Service
OFF
DISABLE FORCE
1234.5
ETM (hours)

FAULT CODE
FLC 1234
LFC 1234
RESET

LOW ALARM
123.4 feet

PUSH TO START LEVEL SIMULATION
DN UP

High Level Pump Cutoff Active
Electrode Out of Sequence
Low-Low Level Pump Cutoff Active

All Pump Disable Active
Flush Cycle Active
Flow Calculator Forcing On Pump(s)

Previous Screen

Station Status - Level Probe Input - 4 Pumps

HIGH ALARM

LEVEL PROBE STATUS

Electrode 1
Electrode 2
Electrode 3
Electrode 4
Electrode 5
Electrode 6
Electrode 7
Electrode 8
Electrode 9
Electrode 10

PUMP 1
Not Available For Service
OFF
DISABLE FORCE
1234.5
ETM (hours)

PUMP 2
Not Available For Service
OFF
DISABLE FORCE
1234.5
ETM (hours)

PUMP 3
Not Available For Service
OFF
DISABLE FORCE
1234.5
ETM (hours)

PUMP 4
Not Available For Service
OFF
DISABLE FORCE
1234.5
ETM (hours)

FAULT CODE
FLC 1234
LFC 1234
RESET

LOW ALARM
123.4 feet

PUSH TO START LEVEL SIMULATION
DN UP

High Level Pump Cutoff Active
Electrode Out of Sequence
Low-Low Level Pump Cutoff Active

All Pump Disable Active
Flush Cycle Active
Flow Calculator Forcing On Pump(s)

Previous Screen

LEVEL CONTROL - Touchscreen HMI SCREENS

Station Status - Level Probe Input - 5 Pumps

HIGH ALARM

LEVEL PROBE STATUS

Electrode 1
Electrode 2
Electrode 3
Electrode 4
Electrode 5
Electrode 6
Electrode 7
Electrode 8
Electrode 9
Electrode 10

LOW ALARM

123.4 feet

PUSH TO START LEVEL SIMULATION

DN UP

Previous Screen

| PUMP 1 | PUMP 2 | PUMP 3 | PUMP 4 | PUMP 5 |
|---------------------------|---------------------------|---------------------------|---------------------------|---------------------------|
| Not Available For Service | Not Available For Service | Not Available For Service | Not Available For Service | Not Available For Service |
| OFF | OFF | OFF | OFF | OFF |
| DISABLE | DISABLE | DISABLE | DISABLE | DISABLE |
| FORCE | FORCE | FORCE | FORCE | FORCE |
| 1234.5 | 1234.5 | 1234.5 | 1234.5 | 1234.5 |
| ETM (hours) | ETM (hours) | ETM (hours) | ETM (hours) | ETM (hours) |

High Level Pump Cutoff Active

Electrode Out of Sequence

Low-Low Level Pump Cutoff Active

All Pump Disable Active

Flush Cycle Active

Flow Calculator Forcing On Pump(s)

FAULT CODE

FLC 1234

LFC 1234

RESET

Station Status - Level Probe Input - 6 Pumps

HIGH ALARM

LEVEL PROBE STATUS

Electrode 1
Electrode 2
Electrode 3
Electrode 4
Electrode 5
Electrode 6
Electrode 7
Electrode 8
Electrode 9
Electrode 10

LOW ALARM

123.4 feet

PUSH TO START LEVEL SIMULATION

DN UP

Previous Screen

| PUMP 1 | PUMP 2 | PUMP 3 | PUMP 4 | PUMP 5 | PUMP 6 |
|---------------------------|---------------------------|---------------------------|---------------------------|---------------------------|---------------------------|
| Not Available For Service | Not Available For Service | Not Available For Service | Not Available For Service | Not Available For Service | Not Available For Service |
| OFF | OFF | OFF | OFF | OFF | OFF |
| DISABLE | DISABLE | DISABLE | DISABLE | DISABLE | DISABLE |
| FORCE | FORCE | FORCE | FORCE | FORCE | FORCE |
| 1234.5 | 1234.5 | 1234.5 | 1234.5 | 1234.5 | 1234.5 |
| ETM (hours) | ETM (hours) | ETM (hours) | ETM (hours) | ETM (hours) | ETM (hours) |

High Level Pump Cutoff Active

Electrode Out of Sequence

Low-Low Level Pump Cutoff Active

All Pump Disable Active

Flush Cycle Active

Flow Calculator Forcing On Pump(s)

FAULT CODE

FLC 1234

LFC 1234

RESET

LEVEL CONTROL - Touchscreen HMI SCREENS

Station Status - Float Inputs - 1 Pump

FLOAT STATUS

- HIGH LEVEL
- OFF LEVEL
- ON LEVEL
- LOW LEVEL

PUMP 1
Not Available For Service

OFF

DISABLE FORCE

1234.5
ETM (hours)

High Level Pump Cutoff Active All Pump Disable Active

Low-Low Level Pump Cutoff Active Float Out of Sequence

FAULT CODE

FLC 1234 RESET

LFC 1234

Previous Screen

Station Status - Float Inputs - 2 Pumps

FLOAT STATUS

- HIGH LEVEL
- OFF LEVEL
- 1ST ON LEVEL
- 2ND ON LEVEL
- LOW LEVEL

PUMP 1
Not Available For Service

OFF

DISABLE FORCE

1234.5
ETM (hours)

High Level Pump Cutoff Active All Pump Disable Active

Low-Low Level Pump Cutoff Active Float Out of Sequence

PUMP 2
Not Available For Service

OFF

DISABLE FORCE

1234.5
ETM (hours)

FAULT CODE

FLC 1234 RESET

LFC 1234

Previous Screen

LEVEL CONTROL - Touchscreen HMI SCREENS

Station Status - Float Inputs - 3 Pumps

This screenshot shows the HMI interface for three pumps. On the left, a vertical stack of buttons represents the float status: HIGH LEVEL, OFF LEVEL, 1ST ON LEVEL, 2ND ON LEVEL, 3RD ON LEVEL, and LOW LEVEL. The main area is divided into three columns for PUMP 1, PUMP 2, and PUMP 3. Each pump's status is 'Not Available For Service' and its control is 'OFF'. Below each 'OFF' button are 'DISABLE' and 'FORCE' buttons. The ETM (hours) for each pump is 1234.5. At the bottom, there are status indicators for 'High Level Pump Cutoff Active', 'Low-Low Level Pump Cutoff Active', 'All Pump Disable Active', and 'Float Out of Sequence'. On the right, a 'FAULT CODE' section shows FLC and LFC both at 1234, with a 'RESET' button.

| Float Status | PUMP 1 | PUMP 2 | PUMP 3 |
|--------------|----------------------------------|---------------------------|---------------------------|
| HIGH LEVEL | Not Available For Service | Not Available For Service | Not Available For Service |
| OFF LEVEL | OFF | OFF | OFF |
| 1ST ON LEVEL | DISABLE | DISABLE | DISABLE |
| 2ND ON LEVEL | FORCE | FORCE | FORCE |
| 3RD ON LEVEL | 1234.5 | 1234.5 | 1234.5 |
| LOW LEVEL | ETM (hours) | ETM (hours) | ETM (hours) |
| | High Level Pump Cutoff Active | All Pump Disable Active | |
| | Low-Low Level Pump Cutoff Active | Float Out of Sequence | |
| | | | FAULT CODE |
| | | | FLC 1234 |
| | | | LFC 1234 |
| | | | RESET |

Station Status - Float Inputs - 4 Pumps

This screenshot shows the HMI interface for four pumps. The layout is similar to the 3-pump screen but includes a fourth pump column. The float status buttons on the left include '4TH ON LEVEL'. Each of the four pumps (PUMP 1-4) is 'Not Available For Service' and 'OFF', with 'DISABLE' and 'FORCE' buttons and an ETM (hours) of 1234.5. The status indicators at the bottom include 'High Level Pump Cutoff Active', 'Low-Low Level Pump Cutoff Active', 'All Pump Disable Active', and 'Float Out of Sequence'. The 'FAULT CODE' section shows FLC and LFC both at 1234, with a 'RESET' button.

| Float Status | PUMP 1 | PUMP 2 | PUMP 3 | PUMP 4 |
|--------------|----------------------------------|---------------------------|---------------------------|---------------------------|
| HIGH LEVEL | Not Available For Service | Not Available For Service | Not Available For Service | Not Available For Service |
| OFF LEVEL | OFF | OFF | OFF | OFF |
| 1ST ON LEVEL | DISABLE | DISABLE | DISABLE | DISABLE |
| 2ND ON LEVEL | FORCE | FORCE | FORCE | FORCE |
| 3RD ON LEVEL | 1234.5 | 1234.5 | 1234.5 | 1234.5 |
| 4TH ON LEVEL | ETM (hours) | ETM (hours) | ETM (hours) | ETM (hours) |
| LOW LEVEL | High Level Pump Cutoff Active | All Pump Disable Active | | |
| | Low-Low Level Pump Cutoff Active | Float Out of Sequence | | |
| | | | | FAULT CODE |
| | | | | FLC 1234 |
| | | | | LFC 1234 |
| | | | | RESET |

LEVEL CONTROL - Touchscreen HMI SCREENS

Station Status - Float Inputs - 5 Pumps

Previous Screen

FLOAT STATUS

- HIGH LEVEL
- OFF LEVEL
- 1ST ON LEVEL
- 2ND ON LEVEL
- 3RD ON LEVEL
- 4TH ON LEVEL
- 5TH ON LEVEL
- LOW LEVEL

| PUMP 1 | PUMP 2 | PUMP 3 | PUMP 4 | PUMP 5 |
|---------------------------|---------------------------|---------------------------|---------------------------|---------------------------|
| Not Available For Service | Not Available For Service | Not Available For Service | Not Available For Service | Not Available For Service |
| OFF | OFF | OFF | OFF | OFF |
| DISABLE | DISABLE | DISABLE | DISABLE | DISABLE |
| FORCE | FORCE | FORCE | FORCE | FORCE |
| 1234.5 | 1234.5 | 1234.5 | 1234.5 | 1234.5 |
| ETM (hours) | ETM (hours) | ETM (hours) | ETM (hours) | ETM (hours) |

High Level Pump Cutoff Active

All Pump Disable Active

Low-Low Level Pump Cutoff Active

Float Out of Sequence

FAULT CODE

FLC 1234

LFC 1234

RESET

Station Status - Float Inputs - 6 Pumps

Previous Screen

FLOAT STATUS

- HIGH LEVEL
- OFF LEVEL
- 1ST ON LEVEL
- 2ND ON LEVEL
- 3RD ON LEVEL
- 4TH ON LEVEL
- 5TH ON LEVEL
- 6TH ON LEVEL
- LOW LEVEL

| PUMP 1 | PUMP 2 | PUMP 3 | PUMP 4 | PUMP 5 | PUMP 6 |
|---------------------------|---------------------------|---------------------------|---------------------------|---------------------------|---------------------------|
| Not Available For Service | Not Available For Service | Not Available For Service | Not Available For Service | Not Available For Service | Not Available For Service |
| OFF | OFF | OFF | OFF | OFF | OFF |
| DISABLE | DISABLE | DISABLE | DISABLE | DISABLE | DISABLE |
| FORCE | FORCE | FORCE | FORCE | FORCE | FORCE |
| 1234.5 | 1234.5 | 1234.5 | 1234.5 | 1234.5 | 1234.5 |
| ETM (hours) | ETM (hours) | ETM (hours) | ETM (hours) | ETM (hours) | ETM (hours) |

High Level Pump Cutoff Active

All Pump Disable Active

Low-Low Level Pump Cutoff Active

Float Out of Sequence

FAULT CODE

FLC 1234

LFC 1234

RESET

LEVEL CONTROL - Touchscreen HMI SCREENS

Station Status - Remote Control Level Input - 1 Pump

LEVEL Remote

123.4 feet

Push To Start Level Simulation

Pump 1

Not Available For Service

OFF

DISABLE FORCE

1234.5

ETM (hours)

HIGH ALARM

LOW ALARM

REMOTE CONTROL LEVEL INPUT

123.4

Parameter: rc.02

High Level Pump Cutoff Active

All Pump Disable Active

Low-Low Level Pump Cutoff Active

Float Backup Control Active

FAULT CODE

FLC 1234

LFC 1234

RESET

Previous Screen

Station Status - Remote Control Level Input - 2 Pumps

LEVEL Remote

123.4 feet

Push To Start Level Simulation

Pump 1

Not Available For Service

OFF

DISABLE FORCE

1234.5

ETM (hours)

Pump 2

Not Available For Service

OFF

DISABLE FORCE

1234.5

ETM (hours)

HIGH ALARM

LOW ALARM

REMOTE CONTROL LEVEL INPUT

123.4

Parameter: rc.02

High Level Pump Cutoff Active

All Pump Disable Active

Low-Low Level Pump Cutoff Active

Float Backup Control Active

FAULT CODE

FLC 1234

LFC 1234

RESET

Previous Screen

LEVEL CONTROL - Touchscreen HMI SCREENS

Station Status - Remote Control Level Input - 3 Pumps

Previous Screen

LEVEL Remote
123.4 feet
Push To Start Level Simulation

| Pump 1 | Pump 2 | Pump 3 |
|---------------------------|---------------------------|---------------------------|
| Not Available For Service | Not Available For Service | Not Available For Service |
| OFF | OFF | OFF |
| DISABLE | FORCE | DISABLE |
| FORCE | DISABLE | FORCE |
| 1234.5 | 1234.5 | 1234.5 |
| ETM (hours) | ETM (hours) | ETM (hours) |

REMOTE CONTROL LEVEL INPUT
123.4
Parameter: rc.02

HIGH ALARM
LOW ALARM

High Level Pump Cutoff Active
All Pump Disable Active
Low-Low Level Pump Cutoff Active
Float Backup Control Active

FAULT CODE
FLC 1234
LFC 1234
RESET

Station Status - Remote Control Level Input - 4 Pumps

Previous Screen

LEVEL Remote
123.4 feet
Push To Start Level Simulation

| PUMP 1 | PUMP 2 | PUMP 3 | PUMP 4 |
|---------------------------|---------------------------|---------------------------|---------------------------|
| Not Available For Service | Not Available For Service | Not Available For Service | Not Available For Service |
| OFF | OFF | OFF | OFF |
| DISABLE | DISABLE | DISABLE | DISABLE |
| FORCE | FORCE | FORCE | FORCE |
| 1234.5 | 1234.5 | 1234.5 | 1234.5 |
| ETM (hours) | ETM (hours) | ETM (hours) | ETM (hours) |

REMOTE CONTROL LEVEL INPUT
123.4
Parameter: rc.02

HIGH ALARM
LOW ALARM

High Level Pump Cutoff Active
All Pump Disable Active
Low-Low Level Pump Cutoff Active
Float Backup Control Active

FAULT CODE
FLC 1234
LFC 1234
RESET

LEVEL CONTROL - Touchscreen HMI SCREENS

Station Status - Remote Control Level Input - 5 Pumps

Previous Screen

| | | | | | |
|--|--|--|--|--|--|
| LEVEL Remote 123.4 feet Push To Start Level Simulation | PUMP 1 <small>Not Available For Service</small> OFF | PUMP 2 <small>Not Available For Service</small> OFF | PUMP 3 <small>Not Available For Service</small> OFF | PUMP 4 <small>Not Available For Service</small> OFF | PUMP 5 <small>Not Available For Service</small> OFF |
| | DISABLE | DISABLE | DISABLE | DISABLE | DISABLE |
| | FORCE | FORCE | FORCE | FORCE | FORCE |
| | 1234.5 | 1234.5 | 1234.5 | 1234.5 | 1234.5 |
| | <small>ETM (hours)</small> | <small>ETM (hours)</small> | <small>ETM (hours)</small> | <small>ETM (hours)</small> | <small>ETM (hours)</small> |

| | | | | | |
|---|------------|----------------------------------|-----------------------------|--|-------|
| REMOTE CONTROL LEVEL INPUT 123.4 <small>Parameter: rc.02</small> | HIGH ALARM | High Level Pump Cutoff Active | All Pump Disable Active | FAULT CODE FLC 1234 LFC 1234 | RESET |
| | LOW ALARM | Low-Low Level Pump Cutoff Active | Float Backup Control Active | | |

Station Status - Remote Control Level Input - 6 Pumps

Previous Screen

| | | | | | | |
|--|--|--|--|--|--|--|
| LEVEL Remote 123.4 feet Push To Start Level Simulation | PUMP 1 <small>Not Available For Service</small> OFF | PUMP 2 <small>Not Available For Service</small> OFF | PUMP 3 <small>Not Available For Service</small> OFF | PUMP 4 <small>Not Available For Service</small> OFF | PUMP 5 <small>Not Available For Service</small> OFF | PUMP 6 <small>Not Available For Service</small> OFF |
| | DISABLE | DISABLE | DISABLE | DISABLE | DISABLE | DISABLE |
| | FORCE | FORCE | FORCE | FORCE | FORCE | FORCE |
| | 1234.5 | 1234.5 | 1234.5 | 1234.5 | 1234.5 | 1234.5 |
| | <small>ETM (hours)</small> | <small>ETM (hours)</small> | <small>ETM (hours)</small> | <small>ETM (hours)</small> | <small>ETM (hours)</small> | <small>ETM (hours)</small> |

| | | | | | |
|---|------------|----------------------------------|-----------------------------|--|-------|
| REMOTE CONTROL LEVEL INPUT 123.4 <small>Parameter: rc.02</small> | HIGH ALARM | High Level Pump Cutoff Active | All Pump Disable Active | FAULT CODE FLC 1234 LFC 1234 | RESET |
| | LOW ALARM | Low-Low Level Pump Cutoff Active | Float Backup Control Active | | |

LEVEL CONTROL - Touchscreen HMI SCREENS

Station Status - Float Backup Inputs - 1 Pump

The screenshot displays the 'FLOAT BACKUP CONTROL STATUS' for a single pump. On the left, a vertical stack of buttons indicates 'FLOAT STATUS' with options: HIGH LEVEL, OFF LEVEL, ON LEVEL, and LOW LEVEL. A 'Float Backup Control Active' indicator is shown at the top left. The main area features 'PUMP 1' controls, including an 'OFF' button, 'DISABLE' and 'FORCE' buttons, and a digital display showing '1234.5' with 'ETM (hours)' below it. Status indicators for 'High Level Pump Cutoff Active', 'Low-Low Level Pump Cutoff Active', and 'All Pump Disable Active' are present. On the right, a 'FAULT CODE' section shows 'FLC 1234' and 'LFC 1234' with a 'RESET' button. A 'Previous Screen' button is located in the top right corner.

Station Status - Float Backup Inputs - 2 Pumps

The screenshot displays the 'FLOAT BACKUP CONTROL STATUS' for two pumps. The layout is similar to the 1-pump screen but includes controls for both 'PUMP 1' and 'PUMP 2'. Each pump has its own 'OFF', 'DISABLE', and 'FORCE' buttons, and a digital display showing '1234.5' with 'ETM (hours)' below it. The 'FLOAT STATUS' buttons on the left include '1ST ON LEVEL' and '2ND ON LEVEL' in addition to 'HIGH LEVEL', 'OFF LEVEL', and 'LOW LEVEL'. The 'FAULT CODE' section on the right shows 'FLC 1234' and 'LFC 1234' with a 'RESET' button. A 'Previous Screen' button is located in the top right corner.

LEVEL CONTROL - Touchscreen HMI SCREENS

Station Status - Float Backup Inputs - 3 Pumps

Float Backup Control Active

FLOAT STATUS

- HIGH LEVEL
- OFF LEVEL
- 1ST ON LEVEL
- 2ND ON LEVEL
- 3RD ON LEVEL
- LOW LEVEL

FLOAT BACKUP CONTROL STATUS Previous Screen

| PUMP 1 | PUMP 2 | PUMP 3 |
|---------------------------|---------------------------|---------------------------|
| Not Available For Service | Not Available For Service | Not Available For Service |
| OFF | OFF | OFF |
| DISABLE FORCE | DISABLE FORCE | DISABLE FORCE |
| 1234.5 | 1234.5 | 1234.5 |
| ETM (hours) | ETM (hours) | ETM (hours) |

High Level Pump Cutoff Active

Low-Low Level Pump Cutoff Active

All Pump Disable Active

FAULT CODE

FLC 1234

LFC 1234

RESET

Station Status - Float Backup Inputs - 4 Pumps

Float Backup Control Active

FLOAT STATUS

- HIGH LEVEL
- OFF LEVEL
- 1ST ON LEVEL
- 2ND ON LEVEL
- 3RD ON LEVEL
- 4TH ON LEVEL
- LOW LEVEL

FLOAT BACKUP CONTROL STATUS Previous Screen

| PUMP 1 | PUMP 2 | PUMP 3 | PUMP 4 |
|---------------------------|---------------------------|---------------------------|---------------------------|
| Not Available For Service | Not Available For Service | Not Available For Service | Not Available For Service |
| OFF | OFF | OFF | OFF |
| DISABLE | DISABLE | DISABLE | DISABLE |
| FORCE | FORCE | FORCE | FORCE |
| 1234.5 | 1234.5 | 1234.5 | 1234.5 |
| ETM (hours) | ETM (hours) | ETM (hours) | ETM (hours) |

High Level Pump Cutoff Active

Low-Low Level Pump Cutoff Active

All Pump Disable Active

FAULT CODE

FLC 1234

LFC 1234

RESET

LEVEL CONTROL - Touchscreen HMI SCREENS

Station Status - Float Backup Inputs - 5 Pumps

Float Backup Control Active

Previous Screen

FLOAT STATUS

- HIGH LEVEL
- OFF LEVEL
- 1ST ON LEVEL
- 2ND ON LEVEL
- 3RD ON LEVEL
- 4TH ON LEVEL
- 5TH ON LEVEL
- LOW LEVEL

| PUMP 1 | PUMP 2 | PUMP 3 | PUMP 4 | PUMP 5 |
|---------------------------|---------------------------|---------------------------|---------------------------|---------------------------|
| Not Available For Service | Not Available For Service | Not Available For Service | Not Available For Service | Not Available For Service |
| OFF | OFF | OFF | OFF | OFF |
| DISABLE | DISABLE | DISABLE | DISABLE | DISABLE |
| FORCE | FORCE | FORCE | FORCE | FORCE |
| 1234.5 | 1234.5 | 1234.5 | 1234.5 | 1234.5 |
| ETM (hours) | ETM (hours) | ETM (hours) | ETM (hours) | ETM (hours) |

High Level Pump Cutoff Active

Low-Low Level Pump Cutoff Active

All Pump Disable Active

FAULT CODE

FLC 1234

LFC 1234

RESET

Station Status - Float Backup Inputs - 6 Pumps

Float Backup Control Active

Previous Screen

FLOAT STATUS

- HIGH LEVEL
- OFF LEVEL
- 1ST ON LEVEL
- 2ND ON LEVEL
- 3RD ON LEVEL
- 4TH ON LEVEL
- 5TH ON LEVEL
- 6TH ON LEVEL
- LOW LEVEL

| PUMP 1 | PUMP 2 | PUMP 3 | PUMP 4 | PUMP 5 | PUMP 6 |
|---------------------------|---------------------------|---------------------------|---------------------------|---------------------------|---------------------------|
| Not Available For Service | Not Available For Service | Not Available For Service | Not Available For Service | Not Available For Service | Not Available For Service |
| OFF | OFF | OFF | OFF | OFF | OFF |
| DISABLE | DISABLE | DISABLE | DISABLE | DISABLE | DISABLE |
| FORCE | FORCE | FORCE | FORCE | FORCE | FORCE |
| 1234.5 | 1234.5 | 1234.5 | 1234.5 | 1234.5 | 1234.5 |
| ETM (hours) | ETM (hours) | ETM (hours) | ETM (hours) | ETM (hours) | ETM (hours) |

High Level Pump Cutoff Active

Low-Low Level Pump Cutoff Active

All Pump Disable Active

FAULT CODE

FLC 1234

LFC 1234

RESET

LEVEL CONTROL - Touchscreen HMI SCREENS

Pump Control & Alarm Setup - Level Setpoints

PUMP CONTROL and ALARM SETUP

PUMP ON / OFF LEVEL CONTROL (feet)

| | | | |
|---------|-------|-------|--------|
| 6th OFF | 123.4 | 123.4 | 6th ON |
| 5th OFF | 123.4 | 123.4 | 5th ON |
| 4th OFF | 123.4 | 123.4 | 4th ON |
| 3rd OFF | 123.4 | 123.4 | 3rd ON |
| 2nd OFF | 123.4 | 123.4 | 2nd ON |
| 1st OFF | 123.4 | 123.4 | 1st ON |

LEVEL ALARMS (feet)

HIGH 123.4

LOW 123.4

FAULT CODE

FLC 1234

LFC 1234

RESET

Previous Screen

Level Input Select

LEVEL INPUT SELECT

Level Input Select 1 Parameter: P.133

- 1 = Analog Level Meter - ALM1 - Single Transducer
- 2 = Analog Level Meter - ALM2 - Single Transducer
- 3 = Analog Level Meter - ALM1 & ALM2 - Manual Switching
- 4 = Analog Level Meter - ALM1 & ALM2 - Automatic Switching
- 5 = Level Probe Meter - LPM1 - Level Probe
- 6 = Float Switch Inputs
- 7 = Remote Control Level Input

Notes:

Selection 3 - Level Input is Manually switched from ALM1 to ALM2 using a Discrete Input.

Selection 4 - Level Input is Automatically switched from ALM1 to ALM2 upon a failure of ALM1.

Selection 5 - Level Probe with 10 Electrodes Connected to 10 Discrete Inputs.

Selection 6 - Float Switches as the primary (and only) Level Input.

Selection 7 - Remote Control Level Input written through SCADA to Parameter RC.02.

Previous Screen

LEVEL - ALM1

123.4

Parameter: Ld.01

LEVEL CONTROL - Touchscreen HMI SCREENS

Pump Alternation Setup

[Previous Screen](#)

PUMP ALTERNATION SETUP

1 **Alternation Sequence Mode**
Parameter: P.122

1 = Standard Alternation: Group 1: Pumps 1-6

2 = Pump 1 Always Lead: Group 1: Pump 1
Group 2: Pumps 2 - 6

3 = Split Alternation - 2&4: Group 1: Pumps 1 - 2
Group 2: Pumps 3 - 6

4 = Split Alternation - 3&3: Group 1: Pumps 1 - 3
Group 2: Pumps 4 - 6

5 = Split Alternation - 4&2: Group 1: Pumps 1 - 4
Group 2: Pumps 5 - 6

1 **Alternation Sequence Modifier A**
Parameter: P.124

0 = Group 1 Pump(s) Are Allowed to Run with Pumps from Group 2

1 = Group 1 Pump(s) Not Allowed to Run with Pumps from Group 2

Group 1 ScreenGroup 2 Screen

Pump Alternation Setup

[Previous Screen](#)

PUMP ALTERNATION SETUP

GROUP 1

Forced Lead Pump Position

1
Parameter: P.129

Force Alternation

1
Parameter: Ad.01

Current Lead Pump

1

0 = Alternate X = Number of Lead Pump

GROUP 1

Time Based Alternation (Internal Time Clock) (minutes)

12345
Parameter: P.131

0 = Disabled 480 = 8 hour
60 = 1 hour 1440 = 24 hour

LEVEL CONTROL - Touchscreen HMI SCREENS

Pump Alternation Setup

[Previous Screen](#)

PUMP ALTERNATION SETUP

GROUP 2

| | | | | |
|---------------------------|------------------|-------------------|------------------|-------------------|
| Forced Lead Pump Position | 1 | Force Alternation | 1 | Current Lead Pump |
| | Parameter: P.130 | | Parameter: Ad.02 | |

0 = Alternate X = Number of Lead Pump

GROUP 2

| | | |
|--|------------------|---|
| Time Based Alternation (Internal Time Clock) (minutes) | 12345 | 0 = Disabled 480 = 8 hour 60 = 1 hour 1440 = 24 hour |
| | Parameter: P.132 | |

Station Control Setup

[Previous Screen](#)

STATION CONTROL SETUP

| | | | |
|---|------------------|--|------------------|
| Pump Mode 1 = Pump Down 2 = Pump Up | 1 | Pump Re-Enable Delay After Low Level Pump Cutoff Float Opens (Pump Down Mode Only) (Seconds) | 123 |
| | Parameter: P.149 | | Parameter: P.153 |
| Lag Pump Delay (seconds) | 123 | | |
| | Parameter: P.150 | | |
| Low Level Alarm Mode 0 = Disable Low Level Alarm 1 = Enable Low Level Alarm | 1 | Pump Re-Enable Delay After High Level Pump Cutoff Float Opens (Pump Up Mode Only) (Seconds) | 123 |
| | Parameter: P.151 | | Parameter: P.154 |

LEVEL CONTROL - Touchscreen HMI SCREENS

VFD Control Setup

VARIABLE FREQUENCY DRIVE SPEED CONTROL SETUP [Previous Screen](#)

Level: ALM1

Pump 1 Pump 2 Pump 3 Pump 4 Pump 5 Pump 6

Level at 100% Speed (feet) Parameter: P.163

Level at Minimum Speed (feet) Parameter: P.162

Minimum Speed (% of full speed) Parameter: P.161

Calculated VFD Speed Reference % Parameter: Pd.41

Pump Start Speed Boost Time (seconds) Parameter: P.164

Speed of Pump Under Remote Control (0% - 100%) Parameter: P.165

Fault Code
 FLC
 LFC

123.4 feet

Flush Cycle Setup

FLUSH CYCLE SETUP & STATUS [Previous Screen](#)

Level: ALM1

Pump 1 Pump 2 Pump 3 Pump 4 Pump 5 Pump 6

Flush Cycle Mode 0 = Flush Cycle Disabled
1 = Flush Cycle Enabled
Parameter: P.171

Flush Cycle Start Level (Feet) Parameter: P.173

Flush Cycle Stop Level (Feet) Parameter: P.174

Normal Pump Operation

Waiting for Well to Fill Up

Calling All Pumps to Run

Time Remaining On Internal Time Delay (minutes)
Parameter: Pd.51

Delay Between Flush Cycles (minutes)
Parameter: P.172

123.4 feet

LEVEL CONTROL - Touchscreen HMI SCREENS

Flow Calculator Data Display

FLOW CALCULATOR - DATA DISPLAY
Previous Screen

Level

123.4

feet

Pump 1

Pump 2

Pump 3

Pump 4

Pump 5

Pump 6

Latest Inflow Rate

12,345

gallons / minute

Parameter: Fd.01

Time Measuring Latest Inflow Rate

123.45

minutes

Parameter: Fd.36

Inflow Totalizer

1,234,512,345

gallons

Parameters: Fd.02

Inflow Totalizer rolls over to zero at:
4,294,967,295 gallons

Inflow Totalizer Reset

Active Determining Latest Inflow Rate

Level Rising Too Fast

Active Forcing On Pump(s)

Next Screen

Flow Calculator Data Display

FLOW CALCULATOR - PUMP DATA DISPLAY
Previous Screen

| Pump Status | Pump Outflow Rate | Pump Run Cycle Time |
|-------------------------------------|---|--|
| Pump 1 <input type="checkbox"/> OFF | Active Determining Pump 1 Outflow Rate <div style="background-color: #e0e0e0; padding: 5px; font-size: 24px; color: cyan;">12,345</div> gallons / minute | <div style="background-color: #e0e0e0; padding: 5px; font-size: 24px; color: cyan;">123.45</div> minutes |
| Pump 2 <input type="checkbox"/> OFF | Active Determining Pump 2 Outflow Rate <div style="background-color: #e0e0e0; padding: 5px; font-size: 24px; color: cyan;">12,345</div> gallons / minute | <div style="background-color: #e0e0e0; padding: 5px; font-size: 24px; color: cyan;">123.45</div> minutes |
| Pump 3 <input type="checkbox"/> OFF | Active Determining Pump 3 Outflow Rate <div style="background-color: #e0e0e0; padding: 5px; font-size: 24px; color: cyan;">12,345</div> gallons / minute | <div style="background-color: #e0e0e0; padding: 5px; font-size: 24px; color: cyan;">123.45</div> minutes |
| Pump 4 <input type="checkbox"/> OFF | Active Determining Pump 4 Outflow Rate <div style="background-color: #e0e0e0; padding: 5px; font-size: 24px; color: cyan;">12,345</div> gallons / minute | <div style="background-color: #e0e0e0; padding: 5px; font-size: 24px; color: cyan;">123.45</div> minutes |
| Pump 5 <input type="checkbox"/> OFF | Active Determining Pump 5 Outflow Rate <div style="background-color: #e0e0e0; padding: 5px; font-size: 24px; color: cyan;">12,345</div> gallons / minute | <div style="background-color: #e0e0e0; padding: 5px; font-size: 24px; color: cyan;">123.45</div> minutes |
| Pump 6 <input type="checkbox"/> OFF | Active Determining Pump 6 Outflow Rate <div style="background-color: #e0e0e0; padding: 5px; font-size: 24px; color: cyan;">12,345</div> gallons / minute | <div style="background-color: #e0e0e0; padding: 5px; font-size: 24px; color: cyan;">123.45</div> minutes |

Parameters: Fd.04 - Fd.09
Parameters: Fd.28 - Fd.33

Level

123.4

feet

Pump Data Reset

Next Screen

LEVEL CONTROL - Touchscreen HMI SCREENS

Flow Calculator Data Display

[Previous Screen](#)

FLOW CALCULATOR - DATA DISPLAY

| | | | |
|---|--|--|--|
| Inflow Total Since the Start of a New Day | 1,234,512,345 gallons <small>Parameters: Fd.12</small> | Average Daily Inflow Total | |
| | | 1,234,512,345 gallons <small>Parameters: Fd.10</small> | |
| Complete Day's Data | Daily Inflow Total | | |
| Newest Data | Day 1 | 1,234,512,345 gallons | |
| | Day 2 | 1,234,512,345 gallons | |
| | Day 3 | 1,234,512,345 gallons | |
| | Day 4 | 1,234,512,345 gallons | |
| | Day 5 | 1,234,512,345 gallons | |
| | Day 6 | 1,234,512,345 gallons | |
| Oldest Data | Day 7 | 1,234,512,345 gallons | |
| | | <small>Parameters: Fd.14 - Fd.26</small> | |

Internal Time Clock
Time Elapsed Since the Start of a New Day
12,345 hours **12** minutes
Parameters: Fd.35 & Fd.34
[Start New Day](#)

[Next Screen](#)

Flow Calculator Setup

[Previous Screen](#)

FLOW CALCULATOR SETUP

1

Flow Calculator Mode
0 = Flow Calculator Disabled - All Flow Data is Reset to Zero
1 = Flow Calculator Enabled - Internal Time Clock
2 = Flow Calculator Enabled - External Time Clock
Parameter: P.175

Surface Area of Wet Well

1,234.5

 square feet
Parameter: P.176

Delay Before Forcing On Another Pump(s)

12

 minutes
Parameter: P.177

Latest Inflow Rate Reset Delay

123

 minutes
Parameter: P.178