

SC5000

INSTRUCTION MANUAL

SECTION 3

PRESSURE CONTROL

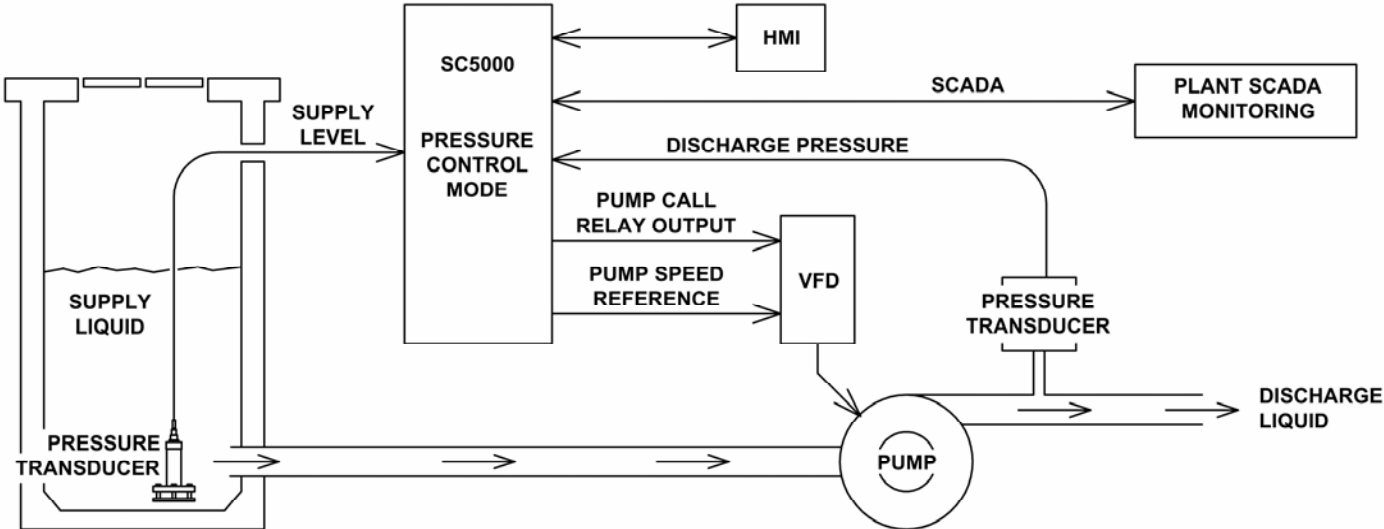

MOTOR PROTECTION ELECTRONICS, LLC

2464 Vulcan Road
Apopka, Florida 32703

Phone: (407) 299-3825
Website: www.mpelectronics.com

SECTION 3

PRESSURE CONTROL

TABLE OF CONTENTS

**Page
Number**

DESCRIPTION OF FEATURES

| | |
|--|-----|
| Description of Features Available in the Pressure Control Mode | 3-2 |
|--|-----|

CONTROL SETUP & DATA DISPLAY

| | |
|---|------|
| Master Control Mode | 3-7 |
| Pump Setup | 3-7 |
| Pump Alternation Setup and Status | 3-8 |
| Supply Level Input Setup and Data | 3-9 |
| Discharge Pressure Input Setup and Data | 3-10 |
| Discharge Pressure Setpoint | 3-11 |
| PID Controller Tuning | 3-11 |
| Pump Speed Reference Data | 3-11 |
| Turning On / Off of Pumps | 3-12 |
| Minimum Pump Speed | 3-12 |
| Pump Operation Enable / Disable | 3-13 |
| Discharge Pressure Setpoint Override - Upon Low Supply Pressure | 3-14 |
| Discharge Pressure Setpoint Override - During Start Up | 3-15 |
| First Pump Start Delay | 3-16 |
| Lag Pump Delay | 3-16 |
| Number of Pumps Required at Startup | 3-16 |
| Re-enable Delay - Pump Cutoff Low-Low Level | 3-16 |
| Pump Speed Acceleration / Deceleration Rate..... | 3-17 |
| Supply Level Alarms | 3-17 |
| Discharge Pressure Alarms | 3-17 |
| Pump Alternation Sequence | 3-18 |
| Analog Level Meters ALM1 and ALM2 | M-1 |
| Analog Pressure Meters APM1 and APM2 | N-1 |

CONNECTION DIAGRAMS

| | |
|---|------|
| Pressure Control Example | 3-19 |
| Analog Level Input Examples - Single and Dual Transducers | M-4 |
| Analog Pressure Input Examples | N-3 |

HMI

| | |
|--|------|
| SC5000-CTS-HMI Screens used for Pressure Control | 3-20 |
|--|------|

PRESSURE CONTROL

DESCRIPTION OF FEATURES

General Description

With the Master Control Mode (Parameter P.091) set for "Pressure Control" the SC5000 will function as a Pressure Controller, and all logic pertaining to "Level Control", "Flow Control" and "Booster Control" will be disabled.

In the Pressure Control Mode, a PID Controller (Proportional, Integral, Derivative) is provided to regulate the pump speed in order to maintain the Discharge Pressure at the Discharge Pressure Setpoint.

The Pressure Control logic also determines the number of pumps required to run in order to maintain the Discharge Pressure at the Discharge Pressure Setpoint.

The Pressure Control logic also alternates the pumps and provides a First Pump Start Delay, Lag Pump Delay, Number of Pumps Required at Startup, Low Level Alarm, High Level Alarm, Low Discharge Pressure Alarm, High Discharge Pressure Alarm, and Pump Cutoff upon Low Level. It also has parameters in the menu that allow the operator to set the Number of Pumps Present, the Maximum Number of Pumps Allowed to Run At the Same Time, and the Maximum Number of Pumps Allowed to Run While On a Generator.

The Pressure Control Mode requires that each pump have its own VFD.

The Pressure Control Mode also requires that the Controller be ordered with an optional Analog Output for each pump for the VFD speed reference (see Ordering Information).

HMI Features

The **SC500-CTS-HMI** is a **Color Touch Screen HMI** programmed with screens that show the Supply Level, Discharge Pressure, Pump Speed Reference, Pump Run Status, Pump Available for Service indication, High Supply Level and Low Supply Level alarms, High Discharge Pressure and Low Discharge Pressure alarms, Discharge Pressure Setpoint Override Active indication, Supply Level Too Low For Pump Operation alarm, Low-Low Level Pump Cutoff Active alarm, Elapsed Run Time meters for each pump, and any Fault Codes that may be present. All the control and alarm settings are made readily available to the operator for viewing or changing. An operator may also perform Level Simulation, reset the Elapsed Run Time meters, and reset any Fault Codes.

Discharge Pressure Setpoint

The Discharge Pressure Setpoint (Parameter P.445) must be set by the operator for the desired Discharge Pressure that the liquid should be pumped at as it leaves the pumping station.

At startup, the Pressure Control logic will bring on the Number of Pumps Required at Startup (Parameter P.470). If number of pumps called at startup are unable to bring the Discharge Pressure up to the Discharge Pressure Setpoint, then another pump will be started. If the setpoint is still not reached, then the control logic will call another pump to run and then another until the Discharge Pressure Setpoint is met. Additionally, the logic will turn off any unneeded pumps.

The PID Controller will follow what is set on the Discharge Pressure Setpoint as it regulates the Discharge Pressure, except when the supply liquid level is low. In this case the Controller may be setup to not strictly following the setpoint, but rather decrease the Discharge Pressure when the supply liquid level is low, and follow the Discharge Pressure Setpoint when the supply liquid level returns to the normal range.

First Pump Start Delay

After power is applied to the Controller and after all the initial conditions are satisfied and the First Pump Start Delay (Parameter P.468) has expired, the Number of Pumps Required at Startup (Parameter P.470) will be started, and the Lag Pump Delay (Parameter P.469) will set the minimum time period between each pump call. The following are the initial conditions which must first be met for the First Pump Start Delay to begin timing out:

There must be an adequate supply of liquid in the well or tank that the pumps are drawing from. The liquid level must be at or above what is set on the Pump Operation Enable Supply Level (Parameter P.459).

The "All Pump Disable" Discrete Input (Discrete Input Function 17) must be open.

The "Pump Cutoff Low-Low Level" Discrete Input (Discrete Input Function 59) must be open and the delay set on the pump Re-enable Delay (Parameter P.153) must have expired.

At least one pump must be available for service (Not having its Pump Disable Discrete Input closed (Discrete Input Functions 11 - 16)).

After all of the above conditions are met and the First Pump Start Delay times out, then the first pump will be started.

PRESSURE CONTROL

Lag Pump Delay

The Lag Pump Delay (Parameter P.469) sets the minimum time period between the calling of pumps to run at startup. It is also used to delay the turning on of the replacement pump when an operating pump is suddenly disabled, or when a time based alternation of the pumps is performed.

Number of Pumps Required at Startup

The Number of Pumps Required at Startup (Parameter P.470) sets the minimum number of pumps that are initially turned on in order to meet the Discharge Pressure Setpoint. When the First Pump Start Delay (Parameter P.468) expires, the first of the required pumps will be turned on and each additional required pump will wait for the Lag Pump Delay (Parameter P.469) to expire.

Pump Turn On and Off

Operating Principal

After the Number of Pumps Required at Startup (Parameter P.470) are started, the Pressure Control logic will then control the number of additional pumps that are required to run in order to maintain the Discharge Pressure at the Discharge Pressure Setpoint. The control logic determines when an additional pump is needed and when to turn off an unneeded pump based on the following operating principal:

The number of pumps required to run is regulated so that the PID Controller does not drive the pump speed reference significantly higher than or lower than a predetermined pump speed range.

See the [Discharge Pressure Versus Pump Speed graph on page 3-12](#).

Turning On Pumps

If at some point conditions in the system require that the pump speed be increased in order to maintain the Discharge Pressure Setpoint, then the pump speed reference will be increased as needed. If the pump speed reference were to be increased to the point that it were equal to or greater than what is set on the Pump Speed Upper Threshold (Parameter P.454), then one additional pump would be turned on, after the delay set on the Delay To Turn On One Pump (Parameter P.455) expires. This may be repeated again and again until all the available pumps are called to run, or until the pump speed becomes lower than the Pump Speed Upper Threshold (Parameter P.454).

Turning Off Pumps

If at some point in time the conditions in the system were to change such that a lower pump speed were required to maintain the Discharge Pressure Setpoint, then the pump speed reference would be decreased as needed. If the pump speed reference were to be decreased to the point where it was equal to or less than what is set on the Pump Speed Lower Threshold (Parameter P.456), then one of the pumps would be turned off, after the delay set on the Delay To Turn Off One Pump (Parameter P.457) expires. This may be repeated again and again until all but one pump is left running, or until the pump speed becomes higher than the Pump Speed Lower Threshold (Parameter P.456).

Pump Operation Enable / Disable

The pump operation in the Pressure Control Mode requires that there be an adequate supply of liquid in the well or tank. The following two parameters provide the operator with control over how low the supply liquid level is allowed to drop before turning off all the pumps and at what level pumping should be allowed to resume:

Pump Operation Enable Supply Level

To allow any pumps to start, the liquid level must first rise up to or be above what is set on the Pump Operation Enable Supply Level (Parameter P.459). See page 3-13.

Pump Operation Disable Supply Level

If the liquid level falls below what is set on the Pump Operation Disable Supply Level (Parameter P.460) then all the pumps will be turned off. See page 3-13.

Alarm Status

When pump operation is disabled, based on Parameters P.459 and P.460, the "Supply Level Too Low for Pump Operation" alarm status bit will be set and may be read from Modbus Coil 258 (Register 40017 Bit 1).

PRESSURE CONTROL

Controlling Setpoint

At start up, the PID Controller is sent a Controlling Setpoint (Parameter Pd.31) that is slowly increased until it equals the Discharge Pressure Setpoint (Parameter P.445). The rate of the increase is set by the Discharge Pressure Ramp Rate (Parameter P.465). [See the graph on page 3-15.](#)

After start up, as long as the Supply Level remains in the normal range (above what is set on Parameter P.462), the Controlling Setpoint will be kept equal to the Discharge Pressure Setpoint and the PID Controller will regulate the pump speed to keep the Discharge Pressure at or near what is set on the Discharge Pressure Setpoint (Parameter P.445).

During start up or at any time, if the Supply Level becomes low (below what is set on Parameter P.462), then the value of the Controlling Setpoint will be ramped down along the linear slope established by Parameters P.461, P.462, P.463 and P.445. [See the graph on page 3-14.](#)

If while the pumps are operating and the Discharge Pressure Setpoint is changed by an operator, then the Controlling Setpoint will be ramped up or down to the new value of the Discharge Pressure Setpoint using the Discharge Pressure Ramp Rate (Parameter P.465).

While the Controlling Setpoint is being ramped up or down to the Discharge Pressure Setpoint, the “PID Controller Setpoint Override Active” status bit will be set and may be read from Modbus Coil 257 (Register 40017 Bit 0).

Pump Alternation

Automatic Alternation

In the Pressure Control Mode the pump Alternation Sequence Mode (Parameter P.122) is fixed to always be in the Standard Alternation, and the pumps will be Alternated “First On First Off”. [See page 3-8.](#)

[See the alternation sequence diagram on page 3-18.](#)

Manual Pump Call Sequence

When manual control over the pump call sequence is desired, the operator can use the Forced Lead Pump Position feature (Parameter P.129) to set the Lead Pump Position. This sets the order the pumps are called in. The Lead Pump Position may also be set using a Lead Pump Selector switch that is connected to Discrete Inputs assigned to Functions 31 - 36. [See page 3-8.](#)

[See connection diagrams on page A-13.](#)

Time Based Alternation

Time Based Alternation is also available in the Pressure Control Mode. The Time Based Alternation logic may be triggered by an Internal Time Clock or from an External Time Clock. The Internal Time Clock alternation period is menu selectable (Parameter P.131). The External Time Clock may be triggered to alternate from either a External Time Clock connected to a Discrete Input on the Controller (set for Function 21), or it may be part of a SCADA system’s logic, where the SCADA system would set Modbus Coil 95 (Register 40006 Bit 14) to force the alternation of the pumps. [See page 3-8.](#)

Pump Cutoff Low-Low Level

The Pump Operation Enable / Disable feature (setup on Parameters P.459 and P.460) monitors the Analog Supply Level Input to determine if there is an adequate supply of liquid in the well or tank. By using a Low-Low Level Float Switch connected to a Discrete Input a redundant pump cut off may also be implemented. This Pump Cutoff Low-Low Level feature also includes a Re-enable Delay to prevent the short cycling of the pumps.

The Low-Low Level Float Switch must be connected to a Discrete Input assigned to Function 59.

The Re-enable Delay (Parameter P.153) starts timing out when the Discrete Input opens. When the Re-enable Delay expires the Pump Cutoff Low-Low Level feature will no longer prevent pump operation.

The “Pump Cutoff Active Low-Low Level” status is available from Modbus Coil 131 (Register 40009 Bit 2).

While the Pump Cutoff Low-Low Level input is closed, the Low Level Alarm will also be activated. The contacts of a relay assigned to the Low Level Alarm (Function 7) will also close.

PRESSURE CONTROL

Supply Level Input Select

The Pressure Control Mode requires an analog 4-20mA Level Input be provided to monitor the liquid level in the wet well. The default Level Input is connected to Analog Level Meter ALM1. If a second or backup Level Input is desired then it must be connected to Analog Level Meter ALM2. The Level Input Select (Parameter P.133) allows for the selection between two Analog Level Meters ALM1 or ALM2 as the Level Input source (each Level Meter must be connected to its own Pressure Transducer). The second analog 4-20mA Level Input may be either manually or automatically switched into service as the controlling Level Input. See Section M.

Discharge Pressure Input Select

The Pressure Control Mode requires that an analog Discharge Pressure Input be provided to the Controller to monitor the Discharge Pressure. The Discharge Pressure Input Select (Parameter P.441) is provided to allow for the selection one of two Analog Pressure Meters APM1, or APM2. See Section N.

PRESSURE CONTROL

Discrete Inputs

30 Discrete Inputs (D1 - D30) that may be setup to perform the following Functions:

- Pump Disable Inputs
- All Pump Disable - Phase Monitor Input
- On Generator - Limits number of pumps allowed to run
- Switch Between ALM1 & ALM2 for Level Input selection
- External Alternation - External Time Clock Input
- Sequence Inputs - Lead Pump Selector Switch Inputs
- Call Pump Last Inputs
- Pump Cutoff Low-Low Level Input
- High and Low Level Alarm Inputs
- Collection of Discrete Input Data for SCADA

Relay Outputs

12 Relay Outputs (ROX1 - ROX12) that may be setup to perform the following Functions:

- Up to Six Pump Call to Run Outputs
- High or Low Supply Level Alarm Outputs
- High or Low Discharge Pressure Alarm Outputs
- SCADA Remote Control Outputs

Analog Inputs

2 Standard Analog Inputs (AIX1 - AIX2) and up to 8 more Optional Analog Inputs (A1 - A8).

The Analog Inputs may be setup to perform one of the following Functions:

- Analog Level Meter ALM1 or ALM2
- Analog Flow Meter AFM1, AFM2 or AFM3
- Analog Pressure Meter APM1 or APM2
- Analog Current Meter ACMA, ACMB or APMC
- Collection of Analog Input Data for SCADA

Analog Outputs

1 Standard Analog Output (AOX1) and up to 6 more Optional Analog Outputs (AO1 - AO6).

The Analog Outputs may be setup to perform one of the following Functions:

- Analog Signal for Pumps 1 - 6 Speed Reference
- Analog Signal for Pumps Speed Reference any Pump (Always Active)
- Analog Signal that is a Copy of Wet Well Level

Pulse Counter Inputs

Option for up to 3 Pulse Counter Inputs (DPC1 - DPC3) that may be used to perform the following:

- Pulse Counter Input for Pulse Flow Meter PFM1, PFM2 or PFM3

PRESSURE CONTROL

| User / Operator Info. | | SCADA | | Description of Parameters and SCADA Notes |
|----------------------------|---------------|---------------|------------------|---|
| Parameter | Default Value | Current Value | Register Address | |
| Master Control Mode | | | | |
| P.091 | 1 | | 40091 | Master Control Mode 1 = Level Control 2 = Flow Control 3 = Pressure Control 4 = Booster Control Must Be Set On "3" for Pressure Control |
| Pump Setup | | | | |
| P.092 | 6 | | 40092 | Number of Pumps Present 1 = 1 Pump 2 = 2 Pumps 3 = 3 Pumps 4 = 4 Pumps 5 = 5 Pumps 6 = 6 Pumps |
| P.093 | 6 | | 40093 | Maximum Number of Pumps Allowed to Run at the Same Time 1 = 1 Pump 2 = 2 Pumps 3 = 3 Pumps 4 = 4 Pumps 5 = 5 Pumps 6 = 6 Pumps |
| P.094 | 6 | | 40094 | Maximum Number of Pumps Allowed to Run While On Generator 1 = 1 Pump 2 = 2 Pumps 3 = 3 Pumps 4 = 4 Pumps 5 = 5 Pumps 6 = 6 Pumps Note: Must Connect Transfer Switch Contact to Discrete Input assigned to Function 18. |

PRESSURE CONTROL

| User / Operator Info. | | | SCADA | Description of Parameters and SCADA Notes |
|--------------------------------|---------------|---------------|------------------|---|
| Parameter | Default Value | Current Value | Register Address | |
| Pump Alternation Setup | | | | |
| P.122 | 1 | 1 | 40122 | <p>Alternation Sequence Mode</p> <p>1 = Standard Alternation of Pumps 1 - 6 See page 3-18.</p> <p>Note: With the Master Control Mode set on Pressure Control the Alternation Sequence Mode will be fixed on Standard Alternation.</p> |
| P.129 | 0 | | 40129 | <p>Forced Lead Pump Position</p> <p>0 = Normal Alternation X = Pump X as Lead</p> |
| P.131 | 0 | | 40131 | <p>Time Based Alternation Range: 0 - 65535 minutes</p> <p>0 = Disabled 60 = 1 hour 480 = 8 hours 1440 = 24 hours</p> <p>Note: Pump Alternation may be triggered using the Internal Time Clock setup using Parameter P.131, or it can also be triggered by an External Time Clock, which may be either a hardware device connected to a Discrete Input setup to perform Function 21, or it may be triggered by having the SCADA system set Bit 14 in Register 40006.</p> |
| Pump Alternation Status | | | | |
| Ad.01 | - | - | 41888 | <p>Current Lead Pump Shows the number of the current Lead Pump.</p> |

PRESSURE CONTROL

| User / Operator Info. | | SCADA | | Description of Parameters and SCADA Notes |
|---------------------------------|---------------|---------------|------------------|---|
| Parameter | Default Value | Current Value | Register Address | |
| Supply Level Input Setup | | | | |
| P.133 | 1 | | 40133 | <p>Level Input Select</p> <p>1 = Analog Level Meter - ALM1 - Single Transducer 2 = Analog Level Meter - ALM2 - Single Transducer 3 = Analog Level Meter - ALM1 & ALM2 - Dual Transducers - Manual Switching 4 = Analog Level Meter - ALM1 & ALM2 - Dual Transducers - Automatic Switching</p> <p>Selection 1 - Level Input is from ALM1. See Section M. Selection 2 - Level Input is from ALM2. See Section M. Selection 3 - Level Input is Manually switched from ALM1 to ALM2. See Section M. Selection 4 - Level Input is Automatically switched from ALM1 to ALM2. See Section M.</p> |
| Supply Level Input Data | | | | |
| Ld.01 | - | - | 42143 | <p>Supply Level Input Data - For Numerical Display of Level</p> <p>Note: This is the value of the Supply Level Input selected on Parameter P.133 scaled into feet and 1/10 of feet for numerical display.</p> |
| Ld.02 | - | - | 42144 | <p>Supply Level Input Data - For Bar Graph Display of Level</p> <p>Note: This is the value of the Supply Level Input selected on Parameter P.133 scaled for display on a bar graph. It is scaled to a range of 0 - 4095. The Bar Graph Display scaling setup on the HMI device must be set for 0 - 4095.</p> |
| Ld.03 | - | - | 42145 | <p>Level Input Source Status</p> <p>1 = Analog Level Meter - ALM1 2 = Analog Level Meter - ALM2 3 = Level - Simulated</p> |

PRESSURE CONTROL

| User / Operator Info. | | SCADA | | Description of Parameters and SCADA Notes |
|---------------------------------------|---------------|---------------|------------------|---|
| Parameter | Default Value | Current Value | Register Address | |
| Discharge Pressure Input Setup | | | | |
| P.441 | 1 | | 40441 | Discharge Pressure Input Select 1 = Analog Pressure Meter APM1 2 = Analog Pressure Meter APM2 Note: This parameter establishes which Analog Pressure Meter's data will be used as the Process Variable (PV) that goes into the PID Controller used for Discharge Pressure Control. The Discharge Pressure data selected here is available to be read from Parameters Pd.21 and Pd.22. See pages N-1 and N-2. |
| P.442 | 100.0 psi | | 40442 | Discharge Pressure Input Bar Graph Span Note: This parameter sets the span of the Discharge Pressure Bar Graph for Parameter Pd.22. |
| Discharge Pressure Input Data | | | | |
| Pd.21 | - | - | 42231 | Discharge Pressure Input Data - For Numerical Display of Pressure Note: This is the value of the pressure data selected on Parameter P.441 scaled into psi for numerical display. |
| Pd.22 | - | - | 42232 | Discharge Pressure Input Data - For Bar Graph Display of Pressure Note: This is the value of the pressure data selected on Parameter P.441 scaled for display on a bar graph. It is scaled to a range of 0 - 4095 by using the "Discharge Pressure Input Bar Graph Span" (Parameter P.442). The Bar Graph Display scaling setup on the HMI device must be set for 0 - 4095. |

PRESSURE CONTROL

| User / Operator Info. | | SCADA | | Description of Parameters and SCADA Notes |
|---|-----------------------|---------------|------------------|--|
| Parameter | Default Value | Current Value | Register Address | |
| Discharge Pressure Setpoint | | | | |
| P.445 | 30.0 psi | | 40445 | Discharge Pressure Setpoint (SP) Range: 3.0 - 300.0 psi Note: This is the parameter that sets the desired Discharge Pressure of the liquid being pumped. |
| Pd.31 | - | - | 42233 | Controlling Setpoint Note: To ensure a smooth stable control of the Discharge Pressure during startup, the value of the Controlling Setpoint (Parameter Pd.31) sent to the PID Controller is ramped up to the value set on the Discharge Pressure Setpoint (Parameter P.445), using the ramp rate set on the Discharge Pressure Ramp Rate (Parameter P.465). If the Supply Level becomes low at startup or at any time (below what is set on Parameter P.462), then the value of the Controlling Setpoint will be ramped down along the linear slope established by Parameters P.461, P.462, P.463 and P.445, as shown on page 3-14. The rate at which it is ramped down (or up) the slope is set on the Discharge Pressure Ramp Rate (Parameter P.465), as shown on page 3-15. |
| At startup or at any time the Setpoint Override logic keeps the Controlling Setpoint from being equal to the Discharge Pressure Setpoint, the "PID Controller Setpoint Override Active" status bit will be set. Its status may be read from Modbus Coil 257 (Register 40017 Bit 0). | | | | |
| PID Controller Tuning | | | | |
| P.447 | 6.40 | | 40447 | Controller Gain (Kc) Range: 0.01 - 30.00 Note: This parameter is used to tune the proportional component of the PID Controller's Pump Speed Reference output. |
| P.448 | 0.02 minutes / repeat | | 40448 | Integral Time (Ti) Range: 0.01 - 60.00 minutes / repeat Note: This parameter is used to tune the integral component of the PID Controller's Pump Speed Reference output. Changes to this parameter may result in significant changes to the Pump Speed Reference. Therefore, it is recommended that only small changes are made to this parameter while the system is in operation. |
| P.449 | 0.00 minutes | | 40449 | Derivative Time (Td) Range: 0.00 - 2.00 minutes Note: This parameter is used to tune the derivative component of the PID Controller's Pump Speed Reference output. |
| Pump Speed Reference Data | | | | |
| Pd.41 | - | | 41877 | Pump Speed Reference Data Range: 0.0 - 100.0 percent Notes: 1. The Pump Speed Reference is determined by the PID Controller and is sent to the VFDs, as a 4-20mA signal, to control the pump speed 2. All operating pumps receive the same Speed Reference. 3. Parameter Pd.41 is the Pump Speed Reference as a percent of full speed. |

PRESSURE CONTROL

Turning On / Off Pumps

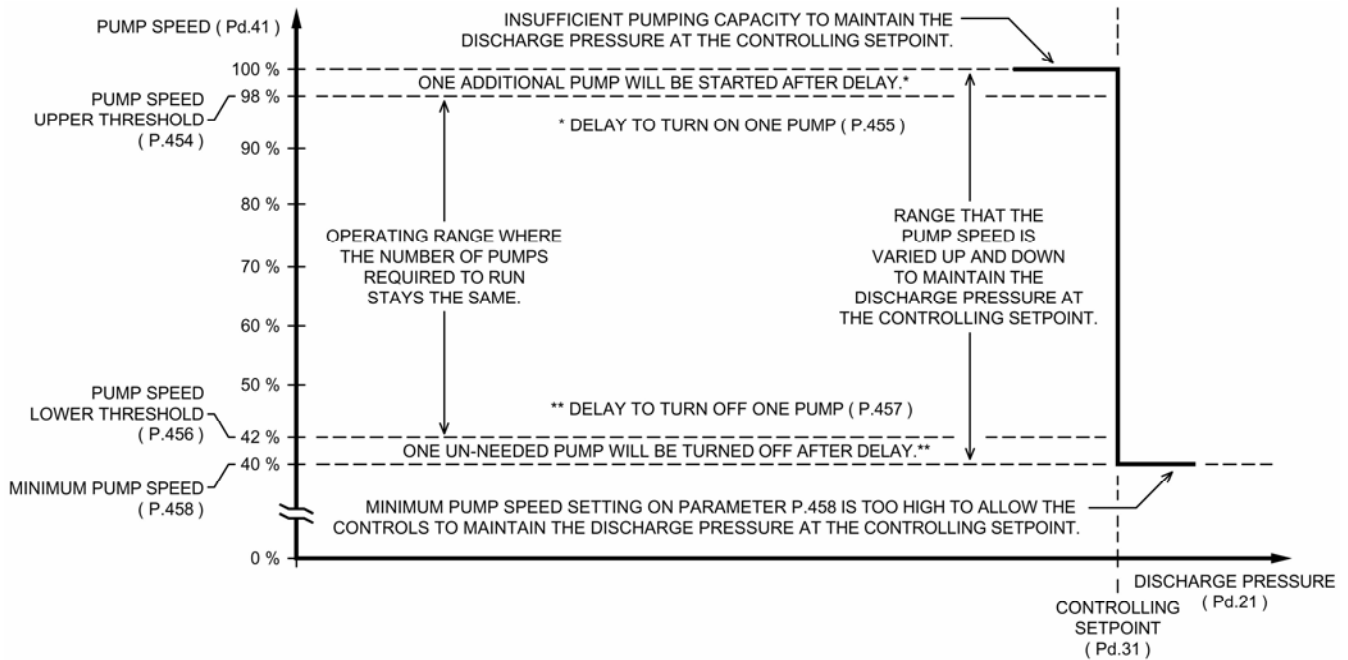

| User / Operator Info. | | SCADA | | Description of Parameters and SCADA Notes |
|-----------------------------|---------------|---------------|------------------|--|
| Parameter | Default Value | Current Value | Register Address | |
| Turning On of Pumps | | | | |
| P.454 | 98.0 % | | 40454 | Pump Speed Upper Threshold Range: 30.0% - 100.0% of Full Speed Note: When the Pump Speed Reference has increased to where it is greater than or equal to what is set on this parameter, the Delay To Turn On One Pump (Parameter P.455) is started. When the delay expires an additional pump will be turned on. |
| P.455 | 10 sec. | | 40455 | Delay To Turn On One Pump Range: 1 - 600 seconds Note: This delay starts when the Pump Speed Reference has increased to where it is greater than or equal to the Pump Speed Upper Threshold (Parameter P.454). When the delay expires an additional pump will be turned on. |
| Turning Off of Pumps | | | | |
| P.456 | 42.0 % | | 40456 | Pump Speed Lower Threshold Range: 10.0% - 90.0% of Full Speed Note: When the Pump Speed Reference has decreased to where it is less than or equal to what is set on this parameter, the Delay To Turn Off One Pump (Parameter P.457) is started. When the delay expires one pump will be turned off. |
| P.457 | 10 sec. | | 40457 | Delay To Turn Off One Pump Range: 1 - 600 seconds Note: This delay starts when the Pump Speed Reference has decreased to where it is less than or equal to the Pump Speed Lower Threshold (Parameter P.456). When the delay expires one pump will be turned off. |
| Minimum Pump Speed | | | | |
| P.458 | 40% | | 40458 | Minimum Pump Speed Range: 0% - 95% of full speed Note: For each application there is usually a minimum speed, below which pump operation is undesirable. This parameter sets the minimum pump speed allowed. With the Minimum Pump Speed set on Parameter P.458, care must be taken that there is not also a minimum speed set on the VFDs. |

PRESSURE CONTROL

Pump Operation Enable / Disable

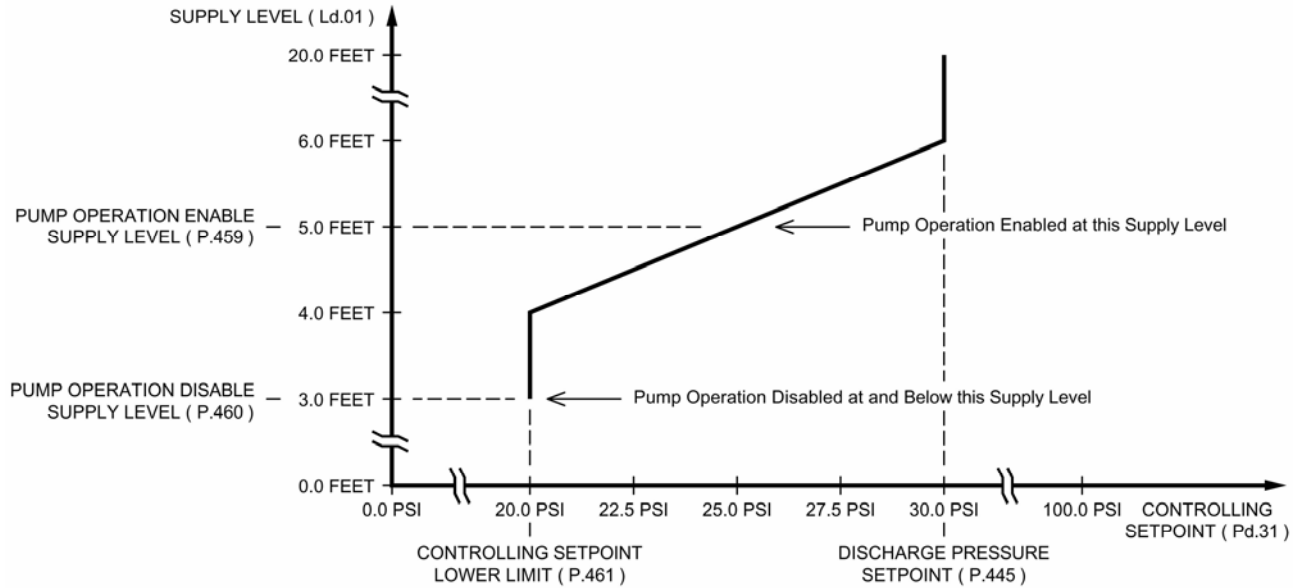

Supply Level Required to Enable Pump Operation

For cases where it is desirable to continue pumping, even when the Supply Level is low, the Controller has a Discharge Pressure Setpoint Override feature. The logic of the feature allows the operator to setup the Controller to continue pumping at a lower Discharge Pressure during a low Supply Level condition.

The purpose of the graph above is to point out the relationship between the Pump Operation Enable and Disable Parameters (P.459 and P.460) and the Discharge Pressure Setpoint Override Ramp, which will be discussed on the next page.

The Pump Operation Enable Supply Level (Parameter P.459) may be located higher or lower than what is shown above, but it must always be set higher than the Pump Operation Disable Supply Level (Parameter P.460).

| User / Operator Info. | | | SCADA | Description of Parameters and SCADA Notes |
|--|---------------|---------------|------------------|---|
| Parameter | Default Value | Current Value | Register Address | |
| Pump Operation Enable / Disable | | | | |
| P.459 | 5.0 feet | | 40459 | Pump Operation Enable Supply Level Range: 0.1 - 231.0 feet Note: This is the supply liquid level at which the operation of all available pumps will be enabled to run as needed to meet the Discharge Pressure Setpoint . |
| P.460 | 3.0 feet | | 40460 | Pump Operation Disable Supply Level Range: 0.1 - 231.0 feet Note: This is the supply liquid level at which all pump operation will be disabled and all pumps will be turned off in order to prevent the level from continuing to lower. |
| When pump operation is disabled, based on Parameters P.459 and P.460, the "Supply Level Too Low for Pump Operation" status bit will be set, and may be read from Modbus Coil 258 (Register 40017 Bit 1). | | | | |

PRESSURE CONTROL

Discharge Pressure Setpoint Override - Upon Low Supply Level

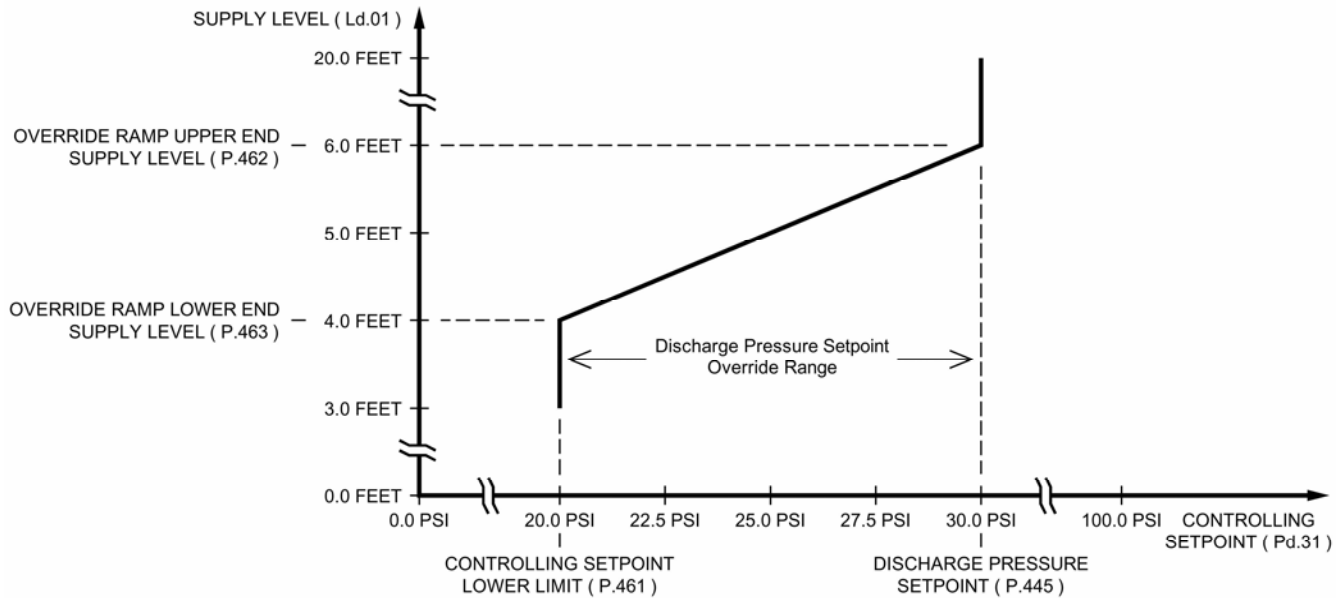

Discharge Pressure Setpoint Override - Upon a Low Supply Level

Upon a low Supply Level condition, where the Supply Level is lower than what is set on Parameter P.462, the Setpoint Override logic will ramp down the Controlling Setpoint as shown in the graph above. This is done to prevent the Supply Level from becoming so low that all pumping would need to be stopped.

Upon a low Supply Level condition the Controlling Setpoint Override logic makes the Controlling Setpoint (Pd.31) lower (or much lower) than the Discharge Pressure Setpoint (P.445). Then the PID Controller responds by ramping down the Pump Speed Reference (Pd.41). The reduced pump speed may prevent the Supply Level from going any lower or at least slow down the decline in Supply Level.

If the low Supply Level condition requires that the Pump Speed Reference (Pd.41) be decreased to the point where it is less than or equal to Parameter P.456, for the time set on Parameter P.457, then the control logic will turn off one or more of the pumps. See Parameters P.456 and P.457 on page 3-12.

| User / Operator Info. | | | SCADA | Description of Parameters and SCADA Notes |
|---|---------------|---------------|------------------|---|
| Parameter | Default Value | Current Value | Register Address | |
| Controlling Setpoint Lower Limit | | | | |
| P.461 | 20.0 psi | | 40461 | Controlling Setpoint Lower Limit Range: 3.0 - 300.0 psi Note: Parameter P.461 sets the lowest value that the Setpoint Override logic is allowed to make the Controlling Setpoint. |
| Override Ramp Upper End Supply Level | | | | |
| P.462 | 6.0 feet | | 40462 | Override Ramp Upper End Supply Level Range: 0.1 - 231.0 feet Note: Parameter P.462 sets the Supply Level that corresponds to where the Setpoint Override logic makes the Controlling Setpoint equal to the Discharge Pressure Setpoint (Parameter P.445). |
| Override Ramp Lower End Supply Level | | | | |
| P.463 | 4.0 feet | | 40463 | Override Ramp Lower End Supply Level Range: 0.1 - 231.0 feet Note: Parameter P.463 sets the Supply Level that corresponds to where the Setpoint Override logic makes the Controlling Setpoint equal to the Controlling Setpoint Lower Limit (Parameter P.461). |
| At startup or at any time the Setpoint Override logic keeps the Controlling Setpoint from being equal to the Discharge Pressure Setpoint, the "PID Controller Setpoint Override Active" status bit will be set. Its status may be read from Modbus Coil 257 (Register 40017 Bit 0). | | | | |

PRESSURE CONTROL

Discharge Pressure Controlling Setpoint - During Start Up

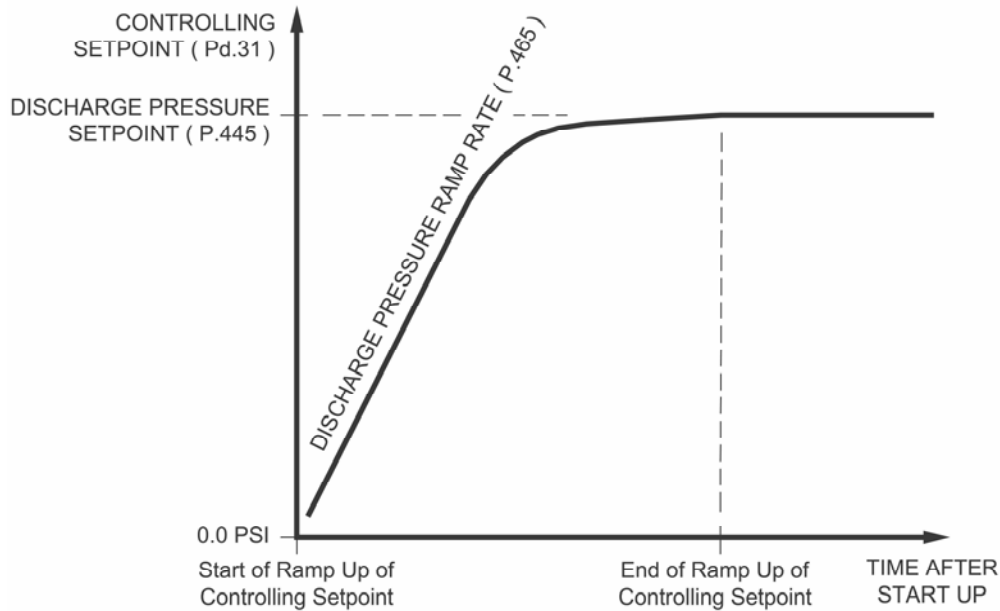

Start Up

During start up, the Pressure Control logic slowly ramps up the Controlling Setpoint (Parameter Pd.31), following the curve shown above. The Discharge Pressure Ramp Rate (Parameter P.465) is provided to set the start up ramp rate.

During start up, with an adequate Supply Level, the Controlling Setpoint (Parameter Pd.31) that is sent to the PID Controller is slowly ramped up until it matches the Discharge Pressure Setpoint (Parameter P.445).

However, if the Supply Level is below what is set on the Override Ramp Upper End Supply Level (Parameter P.462), the control logic will limit the Controlling Setpoint (Pd.31) as shown in the graph on page 3-14.

During start up, for the first 80% of the way to the Discharge Pressure Setpoint, the Controlling Setpoint is increased at the rate set on the Discharge Pressure Ramp Rate (Parameter P.465). Then for the last 20% of the way to the Discharge Pressure Setpoint, the ramp rate is slowly decreased as shown above.

The decrease in the ramp rate at the end of the curve shown above, is to reduce the overshooting of the Discharge Pressure Setpoint at start up.

At start up, if the Discharge Pressure is excessively overshooting the Discharge Pressure Setpoint, reduce the setting on the Discharge Pressure Ramp Rate (Parameter P.465) until the overshooting is within acceptable limits.

| User / Operator Info. | | | SCADA | Description of Parameters and SCADA Notes |
|---|------------------|---------------|------------------|---|
| Parameter | Default Value | Current Value | Register Address | |
| Discharge Pressure Ramp Rate | | | | |
| P.465 | 0.85 psi /sec | | 40465 | Discharge Pressure Ramp Rate Range: 0.10 - 10.00 psi / sec Note: Parameter P.465 sets the initial rate at which the control logic is allowed to change the Discharge Pressure's Controlling Setpoint (Parameter Pd.31). Parameter P.465 must be set so that during start up the Discharge Pressure does not overshooting of the Discharge Pressure Setpoint beyond the acceptable limit. |
| At startup or at any time the Setpoint Override logic keeps the Controlling Setpoint from being equal to the Discharge Pressure Setpoint, the "PID Controller Setpoint Override Active" status bit will be set. Its status may be read from Modbus Coil 257 (Register 40017 Bit 0). | | | | |

PRESSURE CONTROL

| User / Operator Info. | | | SCADA | Description of Parameters and SCADA Notes |
|--|---------------|---------------|------------------|---|
| Parameter | Default Value | Current Value | Register Address | |
| First Pump Start Delay | | | | |
| P.468 | 10 sec. | | 40468 | <p>First Pump Start Delay Range: 1 - 180 seconds</p> <p>Notes: The First Pump Start Delay period starts when all the following conditions are met:</p> <ol style="list-style-type: none"> 1. Power is applied to Controller. 2. The Supply Level is at or above the Pump Operation Enable Supply Level (Parameter P.459). 3. The "All Pump Disable" discrete input (Discrete Input Function 17) is open. 4. The "Pump Cutoff Low-Low Level" discrete input (Discrete Input Function 59) is open and the delay set on the pump Re-enable Delay (Parameter P.153) has expired. 5. At least one Pump is available for service and has its "Pump Disable" discrete input (Discrete Input Functions 11 - 16) open. |
| Lag Pump Delay | | | | |
| P.469 | 5 sec. | | 40469 | <p>Lag Pump Delay Range: 1 - 100 seconds</p> <p>Note: This is the minimum time period between the calling of pumps to run at startup. It is also used to delay the turning on of the replacement pump when an operating pump is suddenly disabled, or when a time based alternation of the pumps is performed.</p> |
| Number of Pumps Required at Startup | | | | |
| P.470 | 1 | | 40470 | <p>Number of Pumps Required at Startup Range: 1 - 6</p> <p>Note: This is the minimum number of pumps that are initially turned on in order to meet the Discharge Pressure Setpoint. When the First Pump Start Delay (Parameter P.468) expires, the first required pump will be turned on and each additional required pump will wait for the Lag Pump Delay (Parameter P.469) to expire.</p> |
| Re-enable Delay - Pump Cutoff Low-Low Level | | | | |
| P.153 | 10 sec. | | 40153 | <p>Re-enable Delay - Pump Cutoff Low-Low Level Range: 1 - 600 seconds</p> <p>Notes:</p> <ol style="list-style-type: none"> 1. While the Low-Low Level Float Switch is closed no pump operation will be allowed. 2. A Low-Low Level Float Switch must be connected to a Discrete Input assigned to Function 59. 3. The Delay starts timing out when the Discrete Input opens. When the Re-enable Delay expires the Pump Cutoff Low-Low Level feature will no longer prevent pump operation. 4. While the Pump Cutoff Low-Low Level input is closed the Low Level Alarm will be active. The contacts of a relay assigned to the Low Level Alarm (Function 7) will also be close. Also, Fault Code 1041 will be generated. |
| <p>The "Pump Cutoff Active Low-Low Level" status is available from Modbus Coil 131 (Register 40009 Bit 2).</p> <p>The "Low Level Alarm" status is available from Modbus Coil 47 (Register 40003 Bit 14).</p> | | | | |

PRESSURE CONTROL

| User / Operator Info. | | SCADA | | Description of Parameters and SCADA Notes |
|---|---------------|---------------|------------------|---|
| Parameter | Default Value | Current Value | Register Address | |
| Pump Speed Acceleration / Deceleration Rate | | | | |
| P.166 | 30 sec. | | 40166 | <p>Pump Speed Acceleration Rate Range: 1 - 100 seconds / 100% speed</p> <p>Notes:</p> <ol style="list-style-type: none"> When a pump is turned on, this is the rate at which the pump's Speed Reference will be increased until it matches the Pump Speed Reference produced by the PID Controller (Parameter Pd.41). This is also the rate at which a pump's Speed Reference will follow increases of the Pump Speed Reference produced by the PID Controller. The setting on Parameter P.166 is the time required for a pump's Speed Reference to go from 0% - 100%. The Controller performs the Acceleration of the pump speed of the individual pumps. Therefore, the Accel Parameter on the VFDs should be set to a value less than or equal to what is set on Parameter P.166. |
| P.167 | 30 sec. | | 40167 | <p>Pump Speed Deceleration Rate Range: 1 - 100 seconds / 100% speed</p> <p>Notes:</p> <ol style="list-style-type: none"> When a pump is turned off, this is the rate at which the pump's Speed Reference will be decreased to 0% speed. This is also the rate at which a pump's Speed Reference will follow decreases of the Pump Speed Reference produced by the PID Controller. The setting on Parameter P.167 is the time required for a pump's Speed Reference to go from 100% - 0%. When a pump is turned off, the pump's Control Relay contact will be kept closed during the Deceleration of the pump to 0% speed, then the contact will be opened. The Controller performs the Deceleration of the pump speed of the individual pumps. Therefore, the Decel Parameter on the VFDs should be set to a value less than or equal to what is set on Parameter P.167. |
| Supply Level Alarms | | | | |
| P.101 | 2.0 feet | | 40101 | <p>Low Level Alarm Range: 0.0 - 231.0 feet</p> <p>Notes:</p> <ol style="list-style-type: none"> This sets the level at which the Low Level Alarm will be activated. The Low Level Alarm operation is delayed for 90 seconds after power is applied. The Low Level Alarm does not act as a redundant pump off. A Float Switch connected to a Discrete Input assigned to either Function 59 or 61 will also activate the Low Level Alarm. Upon a Low Level Alarm, the contacts of a relay assigned to Function 7 will close. |
| The "Low Level Alarm" status is available from Modbus Coil 47 (Register 40003 Bit 14). | | | | |
| P.102 | 10.0 feet | | 40102 | <p>High Level Alarm Range: 0.1 - 231.0 feet</p> <p>Notes:</p> <ol style="list-style-type: none"> This sets the level at which the High Level Alarm will be activated. The High Level Alarm operation is delayed for 10 seconds after power is applied. A Float Switch connected to a Discrete Input assigned to Function 62 will also activate the High Level Alarm. Upon a High Level Alarm, the contacts of a relay assigned to Function 8 will close. |
| The "High Level Alarm" status is available from Modbus Coil 48 (Register 40003 Bit 15). | | | | |
| Discharge Pressure Alarms | | | | |
| P.393 | 20.0 psi | | 40393 | <p>Low Discharge Pressure Alarm Range: 0.0 - 300.0 psi</p> <p>Note: Upon a Low Discharge Pressure Alarm, the contacts of a relay assigned to Function 13 will close.</p> |
| The "Low Discharge Pressure Alarm" status is available from Modbus Coil 267 (Register 40017 Bit 10). | | | | |
| P.394 | 70.0 psi | | 40394 | <p>High Discharge Pressure Alarm Range: 0.1 - 300.0 psi</p> <p>Note: Upon a High Discharge Pressure Alarm, the contacts of a relay assigned to Function 14 will close.</p> |
| The "High Discharge Pressure Alarm" status is available from Modbus Coil 268 (Register 40017 Bit 11). | | | | |

PUMP ALTERNATION SEQUENCE

STANDARD ALTERNATION Parameter P.122 = 1

With the Master Control Mode set on Pressure Control the Alternation Sequence Mode will be fixed on Standard Alternation (Parameter P.122 = 1).

The pumps will be Alternated “First On First Off”.

Discrete Inputs assigned the Function of “Pump Disable” (Functions 11 - 16) inputs may be used to disable pumps so that they will not be called to run.

Discrete Inputs assigned the Function of “Call Pump Last” (Functions 41 - 46) may be used to assign pumps to standby status, where they will only be called to run if no other pumps are available.

Discrete Inputs assigned the Function of “Sequence Input” (Functions 31 - 36) may be used to set the lead pump.

The “Forced Lead Pump Position” (Parameter P.129) may be used to set the lead pump.

“Time Based Alternation” (Parameter P.131) may be setup to force an alternation using an Internal Time Clock.

A Discrete Input assigned the Function of “External Alternation” (Function 21) may be connected to an External Time Clock and used to force an alternation.

A SCADA system may initiate an alternation by momentarily setting Modbus Coil 95 (Register 40006, Bit 14).

Movement of Lead Pump Upon Alternation

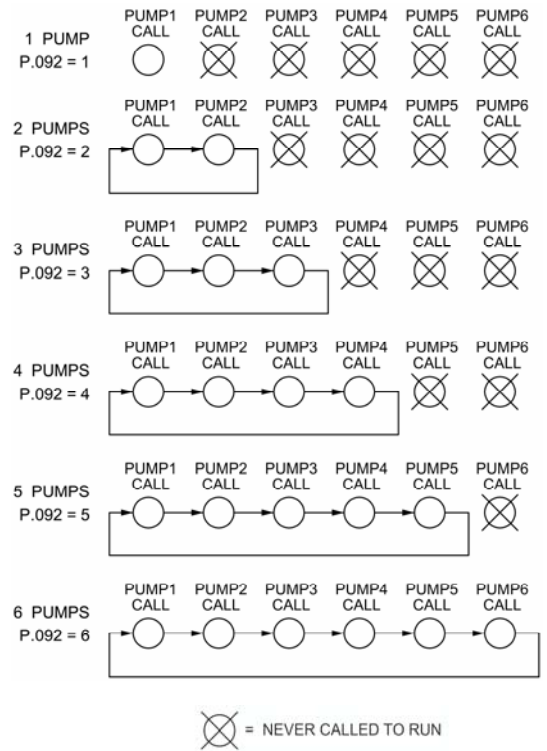

PRESSURE CONTROL EXAMPLE

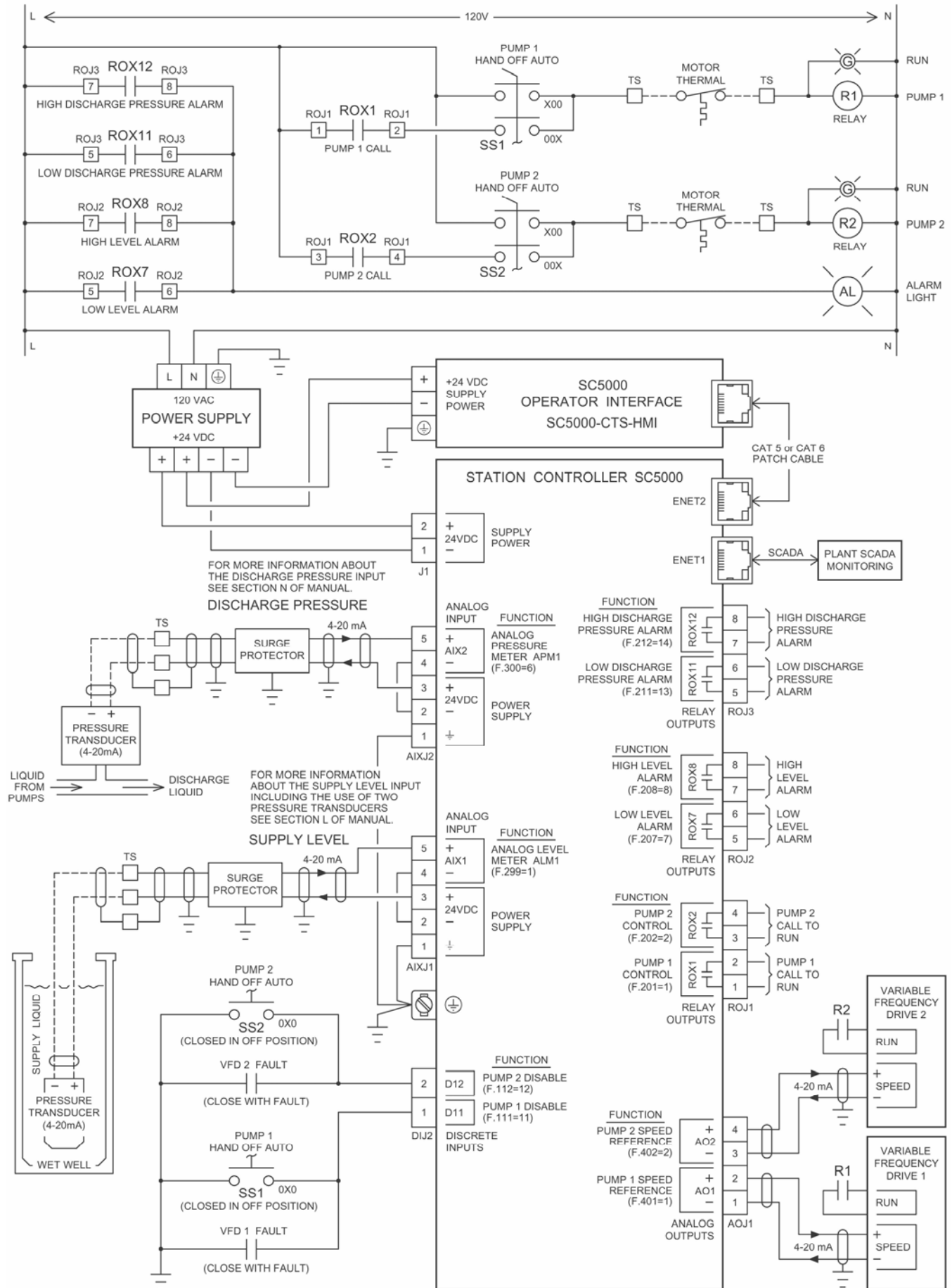

PRESSURE CONTROL - Touchscreen HMI SCREENS

Main Screen

The main screen of the Station Controller SC5000 is divided into several functional areas:

- Fault Code:** Displays FLC 1234 and LFC 1234 with a Reset button.
- I/O:** Includes buttons for Discrete Inputs, Relay Outputs, Analog Inputs, and Analog Outputs.
- Meters:** Features buttons for Level, Pressure, Flow, and Current.
- Control Mode Select:** A central menu with buttons for Pump Setup, Security Setup, SCADA Setup, and Backup / Restore.
- Parameter Security:** Shows PARAMETERS UNLOCKED and a Security Code Entry button.
- Station Status & Setup:** A large button at the bottom right for accessing station status and configuration.

Control Mode Select

The Control Mode Select screen displays the following information:

- CONTROL MODE SELECT:** The main title of the screen.
- Previous Screen:** A button to navigate back to the main screen.
- Master Control Mode:** A large box containing the number 1, indicating the selected mode.
- Parameter: P.091:** The parameter name for the selected mode.
- Mode Legend:**
 - 1 = Level Control
 - 2 = Flow Control
 - 3 = Pressure Control
 - 4 = Booster Control

PRESSURE CONTROL - Touchscreen HMI

Pump Setup

PUMP SETUP

[Previous Screen](#)

Number of Pumps Present
Parameter: P.092

Maximum Number of Pumps Allowed To Run At The Same Time
Parameter: P.093

Maximum Number of Pumps Allowed To Run While On Generator
(See Discrete Input Function 18) Parameter: P.094

Pressure Control Main Screen

SC5000 PRESSURE CONTROL

[Main Screen](#)

Fault Code
FLC
LFC

Parameter Security
PARAMETERS LOCKED

PRESSURE CONTROL - Touchscreen HMI SCREENS

Station Status

The Station Status screen displays the following information:

- Supply Level:** ALM1, High Alarm, Low Alarm, 123.4 feet, Push To Start Level Simulation.
- Discharge Pressure:** High Alarm, Low Alarm, 123.4 psi, Pump Speed Reference 123.4 %.
- Pumps 1-6:** All are 'Not Available For Service'. Each pump has buttons for OFF, DISABLE, FORCE, ELAPSED RUN TIME (HOURS), and RESET. Current FORCE values are 1234.5.
- Controlling Setpoint:** 123.4 psi.
- Pressure Setpoint:** 123.4 psi.
- Active Faults:** All Pump Disable Active, Supply Level Too Low for Pump Operation, Low-Low Level Pump Cutoff Active, Pressure Setpoint Override Active.
- Fault Codes:** FLC 1234, LFC 1234, with a RESET button.
- Navigation:** Previous Screen button.

Discharge Pressure Setup

The Discharge Pressure Setup screen includes the following configuration options:

- DISCHARGE PRESSURE SETUP:** Title and Previous Screen button.
- Discharge Pressure:** 123.4 psi (Parameter: Pd.21).
- Discharge Pressure Setpoint:** 123.4 psi (Parameter: P.445).
- Configuration Buttons:** Discharge Pressure Input Setup and PID Controller Tuning.

PRESSURE CONTROL - Touchscreen HMI SCREENS

Discharge Pressure Input Setup

DISCHARGE PRESSURE INPUT SETUP

Previous Screen

Discharge Pressure Input Select

1

Parameter: P.441

1 = Pressure Meter APM1
2 = Pressure Meter APM2

The selected Analog Pressure Meter APM1 or APM2 must be setup before using. To Setup go to the Main Screen and select "Pressure".

Discharge Pressure

Parameter: Pd.22

123.4

 psi

Discharge Pressure Input Bar Graph Span

123.4

 psi

Parameter: P.442

123.4

 psi

PID Controller Tuning

PID CONTROLLER TUNING

Previous Screen

Pump 1Pump 2Pump 3Pump 4Pump 5Pump 6

Supply Level

123.4

 feet

Discharge Pressure

123.4

 psi

Controller Gain (Kc)

12.34

Parameter: Ld.01 Parameter: Pd.21 Parameter: P.447

Discharge Pressure Setpoint

123.4

 psi

Discharge Pressure Controlling Setpoint

123.4

 psi

Integral Time (Ti) (minutes / repeat)

12.34

Parameter: P.445 Parameter: Pd.31 Parameter: P.448

Pump Speed Reference

123.4

 %

Derivative Time (Td) (minutes)

12.34

Speed Reference Component Values

Proportional

+

12,345,123

-

12,345,123

Integral

12,345,123

Derivative

+

12,345,123

-

12,345,123

Parameter: Pd.41 Parameter: P.449

Pressure Setpoint
Override Active

Supply Level Too Low
for Pump Operation

PRESSURE CONTROL - Touchscreen HMI SCREENS

Control Setup

CONTROL SETUP

[Previous Screen](#)

Setup To Turn On Pumps

| | | | |
|-------------------------------|---|---|---|
| Pump Speed Upper Threshold | <input style="width: 100%;" type="text" value="123.4"/> % | <input style="width: 100%;" type="text" value="123"/> | Delay To Turn On One Pump (seconds) |
| | <small>Parameter: P.454</small> | <small>Parameter: P.455</small> | |

Setup To Turn Off Pumps

| | | | |
|-------------------------------|---|---|--|
| Pump Speed Lower Threshold | <input style="width: 100%;" type="text" value="123.4"/> % | <input style="width: 100%;" type="text" value="123"/> | Delay To Turn Off One Pump (seconds) |
| | <small>Parameter: P.456</small> | <small>Parameter: P.457</small> | |

| | | |
|-----------------------|--|--|
| Minimum Pump Speed | <input style="width: 100%;" type="text" value="12"/> % | |
| | <small>Parameter: P.458</small> | |

[Next Screen](#)

Control Setup

CONTROL SETUP

[Previous Screen](#)

**Pump Operation Enable
Supply Level**

| |
|--|
| <input style="width: 100%;" type="text" value="123.4"/> feet |
| <small>Parameter: P.459</small> |

**Pump Operation Disable
Supply Level**

| |
|--|
| <input style="width: 100%;" type="text" value="123.4"/> feet |
| <small>Parameter: P.460</small> |

[Next Screen](#)

PRESSURE CONTROL - Touchscreen HMI SCREENS

Control Setup

CONTROL SETUP

[Previous Screen](#)

| | |
|--|---|
| <p>Override Ramp Upper End Supply Level</p> <div style="border: 1px solid blue; padding: 5px; display: inline-block; font-size: 24px; margin-right: 10px;">123.4</div> feet <small>Parameter: P.462</small> | <p>Controlling Setpoint Lower Limit</p> <div style="border: 1px solid blue; padding: 5px; display: inline-block; font-size: 24px; margin-right: 10px;">123.4</div> psi <small>Parameter: P.461</small> |
| <p>Override Ramp Lower End Supply Level</p> <div style="border: 1px solid blue; padding: 5px; display: inline-block; font-size: 24px; margin-right: 10px;">123.4</div> feet <small>Parameter: P.463</small> | <p>Discharge Pressure Ramp Rate</p> <div style="border: 1px solid blue; padding: 5px; display: inline-block; font-size: 24px; margin-right: 10px;">12.34</div> psi / sec <small>Parameter: P.465</small> |

[Next Screen](#)

Control Setup

CONTROL SETUP

[Previous Screen](#)

| | |
|--|--|
| <p>First Pump Start Delay</p> <div style="border: 1px solid blue; padding: 5px; display: inline-block; font-size: 24px; margin-right: 10px;">123</div> seconds <small>Parameter: P.468</small> | <p>Lag Pump Delay</p> <div style="border: 1px solid blue; padding: 5px; display: inline-block; font-size: 24px; margin-right: 10px;">123</div> seconds <small>Parameter: P.469</small> |
| <p>Re-Enable Delay Pump Cutoff Low-Low Level</p> <div style="border: 1px solid blue; padding: 5px; display: inline-block; font-size: 24px; margin-right: 10px;">123</div> seconds <small>Parameter: P.153</small> | <p>Number of Pumps Required at Startup</p> <div style="border: 1px solid blue; padding: 5px; display: inline-block; font-size: 24px; margin-right: 10px;">123</div> <small>Parameter: P.470</small> |

Note: The Discrete Input used for Pump Cutoff Low-Low Level must have its Discrete Input Setup parameter set for Function 59.

[Next Screen](#)

PRESSURE CONTROL - Touchscreen HMI SCREENS

Control Setup

CONTROL SETUP

Previous Screen

**Pump Speed
Acceleration Rate**

123

seconds / 100% speed
(The time required to go from 0% to 100% speed.)

Parameter: P.166

**Pump Speed
Deceleration Rate**

123

seconds / 100% speed
(The time required to go from 100% to 0% speed.)

Parameter: P.167

Note:
The Controller performs the Acceleration and Deceleration of the pump speed.
The Accel and Decel Parameters on the VFDs should be set to values less than or equal to what is set above.

Next Screen

Control Setup

CONTROL SETUP

Previous Screen

Level Input Select

1

Parameter: P.133

- 1 = Analog Level Meter - ALM1 - Single Transducer
- 2 = Analog Level Meter - ALM2 - Single Transducer
- 3 = Analog Level Meter - ALM1 & ALM2 - Manual Switching
- 4 = Analog Level Meter - ALM1 & ALM2 - Automatic Switching

Supply Level

ALM1

123.4feet

Parameter: Ld.01

Notes:
Selection 3 - Level Input is Manually switched from ALM1 to ALM2 using a Discrete Input.
Selection 4 - Level Input is Automatically switched from ALM1 to ALM2 upon a failure of ALM1.

PRESSURE CONTROL - Touchscreen HMI SCREENS

Pump Alternation Setup

[Previous Screen](#)

PUMP ALTERNATION SETUP

Forced Lead Pump Position

Parameter: P.129

Force Alternation

Parameter: Ad.01

Current Lead Pump

0 = Alternate
1 = Pump 1 Lead Pump
2 = Pump 2 Lead Pump
3 = Pump 3 Lead Pump
4 = Pump 4 Lead Pump
5 = Pump 5 Lead Pump
6 = Pump 6 Lead Pump

Time Based Alternation
(Internal Time Clock)

0 = Disabled
60 = 1 hour
480 = 8 hour
1440 = 24 hour

minutes

Parameter: P.131

Alarms Setup

[Previous Screen](#)

ALARMS SETUP

Supply Level Alarms

High Level Alarm

feet

Parameter: P.102

Low Level Alarm

feet

Parameter: P.101

Discharge Pressure Alarms

High Discharge Pressure Alarm

psi

Parameter: P.394

Low Discharge Pressure Alarm

psi

Parameter: P.393