

# SECTION I

## FLOAT BACKUP & FLOAT CONTROL

Revision Date: 4-29-24

### Float Backup

The Float Backup feature uses Float Switches connected to Discrete Inputs as a backup for the other types of level input (Transducer Input, Level Probe Input or Remote Control Level Input (Parameter P.22 = 1, 2 or 4)).

Float Backup will operate in the background and is capable of adding to the number of pumps that may be called to run by the primary level controls. It will operate for both Pump Down and Pump Up applications.

When the Float Backup logic is active calling one or more pumps to run, the Fault LED will be turned on, and fault code of 1050 will be generated. The Fault LED and Fault Code signals the operator of a possible issue with the primary controls.

For more information on Float Backup see page I-4.

### Float Control

The Float Control feature uses Float Switches connected to Discrete Inputs as the primary and only level input. All other level inputs (Transducer, Level Probe and Remote Control Input) are ignored and not used to call pumps to run.

For Float Control to be the primary and only means to control the pumps, the Level Input Select (Parameter P.22) must be set for Float Switch Inputs (Parameter P.22 = 3).

The Float Control feature will operate for both Pump Down and Pump Up applications.

In the Float Control mode (Parameter P.22 = 3) the following changes are made to the Controller's operation:

The Level Display is made blank rather than displaying – 0.0 feet.

The Fault LED will not be turned on every time the Float Control is active calling pumps to run, and the fault code of 1050 will not be generated.

Float Out of Sequence logic will be active generating Fault Codes to aid in troubleshooting float issues. Fault Codes 1051, 1052, and 1053 are provided to indicate which float is out of sequence.

For more information on Float Control see page I-5.

### Pump Cutoff - Low-Low Level (Pump Down Mode)

When a Discrete Input assigned the Function of "Pump Cutoff - Low-Low Level" (Function 13) is closed, the Low Level Alarm will be activated, pump operation (Pump Down Mode only) will be disabled and Fault Code 1041 will be generated.

This feature when activated disables all pump operation from both the primary and backup control.

This feature will only operate in the Pump Down Mode (Parameter P.31 = 1).

Pump operation will not be re-enabled until the Low-Low Level input opens and the Pump Re-enable Delay - Pump Cutoff Low-Low Level (Parameter P.35) expires.

When a Discrete Input assigned the Function of "Pump Cutoff - Low-Low Level" (Function 13) is closed an Output Relay, assigned Relay Output Function 2, will close its contacts.

### Pump Cutoff - High-High Level (Pump Up Mode)

When a Discrete Input assigned the Function of "Pump Cutoff - High-High Level" (Function 14) is closed, the High Level Alarm will be activated, pump operation (Pump Up Mode only) will be disabled and Fault Code 1042 will be generated.

This feature when activated disables all pump operation from both the primary and backup control.

This feature will only operate in the Pump Up Mode (Parameter P.31 = 2).

Pump operation will not be re-enabled until the High-High Level input opens and the Pump Re-enable Delay - Pump Cutoff High-High Level (Parameter P.36) expires.

When a Discrete Input assigned the Function of "Pump Cutoff - High-High Level" (Function 14) is closed an Output Relay, assigned Relay Output Function 1, will close its contacts.

## DISCRETE INPUT SETUP

User / Operator Info.			SCADA	Description of Parameters and SCADA Notes
Parameter	Default Value	Current Value	Register Address	
<b>Discrete Input Setup</b>				
<b>Discrete Input Function</b>			<b>Discrete Input</b>	
F.01	1		40301	Discrete Input - D1
F.02	2		40302	Discrete Input - D2
F.03	3		40303	Discrete Input - D3
F.04	4		40304	Discrete Input - D4
F.05	5		40305	Discrete Input - D5
F.06	6		40306	Discrete Input - D6
F.07	7		40307	Discrete Input - D7
F.08	8		40308	Discrete Input - D8
F.09	9		40309	Discrete Input - D9
F.10	10		40310	Discrete Input - D10
F.11	11		40311	Discrete Input - D11
F.12	12		40312	Discrete Input - D12

**Function of Discrete Input:**

Alarm Only

11 = Low Level Alarm Only ..... Float Switch  
 12 = High Level Alarm Only ..... Float Switch

Pump Cutoff & Alarm

13 = Pump Cutoff - Low-Low Level (Pump Down Mode).... Float Switch  
 14 = Pump Cutoff - High-High Level (Pump Up Mode) ..... Float Switch

Pump Control & Alarm

15 = Pump Control – Off Level ..... Float Switch  
 16 = Pump Control – 1st On Level ..... Float Switch  
 17 = Pump Control – 2nd On Level ..... Float Switch  
 18 = Pump Control – 3rd On Level ..... Float Switch  
 19 = Pump Control – High Level (Pump Down Mode).....Float Switch

**Connect To:**

## PUMP CUTOFF SETUP

User / Operator Info.			SCADA	Description of Parameters and SCADA Notes
Parameter	Default Value	Current Value	Register Address	
P.35	10 sec.		40135	<p>Pump Re-enable Delay - Pump Cutoff Low-Low Level Range: 1 - 600 sec.</p> <p>Notes:</p> <ol style="list-style-type: none"> <li>1. This is only used in the Pump Down Mode (Parameter P.31 = 1).</li> <li>2. While the Low-Low Level Float Switch is closed no pump operation will be allowed.</li> <li>3. A Low-Low Level Float Switch must be connected to a Discrete Input assigned to Function 13.</li> <li>4. The Delay starts timing out when the Discrete Input opens. When the Re-enable Delay expires the Pump Cutoff Low-Low Level feature will no longer prevent pump operation.</li> <li>5. While the Pump Cutoff Low-Low Level input is closed the Low Level Alarm will be active. The contacts of a relay assigned to the Low Level Alarm (Function 2) will also be close. Also, Fault Code 1041 will be generated.</li> </ol>
P.36	10 sec.		40136	<p>Pump Re-enable Delay - Pump Cutoff High-High Level Range: 1 - 600 sec.</p> <p>Notes:</p> <ol style="list-style-type: none"> <li>1. This is only used in the Pump Up Mode (Parameter P.31 = 2).</li> <li>2. While the High-High Level Float Switch is closed no pump operation will be allowed.</li> <li>3. A High-High Level Float Switch must be connected to a Discrete Input assigned to Function 14.</li> <li>4. The Delay starts timing out when the Discrete Input opens. When the Re-enable Delay expires the Pump Cutoff High-High Level feature will no longer prevent pump operation.</li> <li>5. While the Pump Cutoff High-High Level input is closed the High Level Alarm will be active. The contacts of a relay assigned to the High Level Alarm (Function 1) will also be close. Also, Fault Code 1042 will be generated.</li> </ol>

# SCADA STATUS

SCADA Register Address	Description of Register Contents (Where a Modbus Coil is represented by a Bit in a Register)																
	40001	16	15	14	13	12	11	10	9	8	7	6	5	4	3	2	1
								Float Control Active Calling Pump(s) to Run							Low Level Alarm Status From All Source	High Level Alarm Status From All Source	
15		14	13	12	11	10	9	8	7	6	5	4	3	2	1	0	Bit
40008	128	127	126	125	124	123	122	121	120	119	118	117	116	115	114	113	Coil
	Low Level Alarm Float Status Discrete Input Functions 11, 13	Pump Control - 1st On Level Discrete Input Function 16	Pump Control - 2nd On Level Discrete Input Function 17	Pump Control - 3rd On Level Discrete Input Function 18					High Level Alarm Float Status Discrete Input Functions 12, 14, 19	Pump Control - Off Level Discrete Input Function 15							
	15	14	13	12	11	10	9	8	7	6	5	4	3	2	1	0	Bit
40009	144	143	142	141	140	139	138	137	136	135	134	133	132	131	130	129	Coil
											Float Control Fault Status Float Out of Sequence		Pump Cutoff High-High Level Active Disabling Pump Operation	Pump Cutoff Low-Low Level Active Disabling Pump Operation	Low Level Alarm Status From All Source	High Level Alarm Status From All Source	
	15	14	13	12	11	10	9	8	7	6	5	4	3	2	1	0	Bit

# FLOAT BACKUP - PUMP DOWN

The Float Backup feature uses Float Switches connected to Discrete Inputs as a backup for the other types of level input (Transducer Input, Level Probe Input or Remote Control Level Input (Parameter P.22 = 1, 2 or 4)).

## Typical Float Backup

To form a typical float backup system, there must be an Off Float, 1st On, 2nd On, and 3rd On Floats as needed for the number of pumps at the lift station.

## Two Float Backup

To form a two float backup system, there must be an Off Float but the 1st On, 2nd On and 3rd On Floats may all be replaced with the High Level Float connected to an input assigned Function 19.

When the "Pump Control - Off Level" (Function 15) input is closed, closure of the "Pump Control - High Level" (Function 14) will cause the Pump Control logic to issue a pump call to run for all available pumps, with a Lag Pump Delay between each pump call.

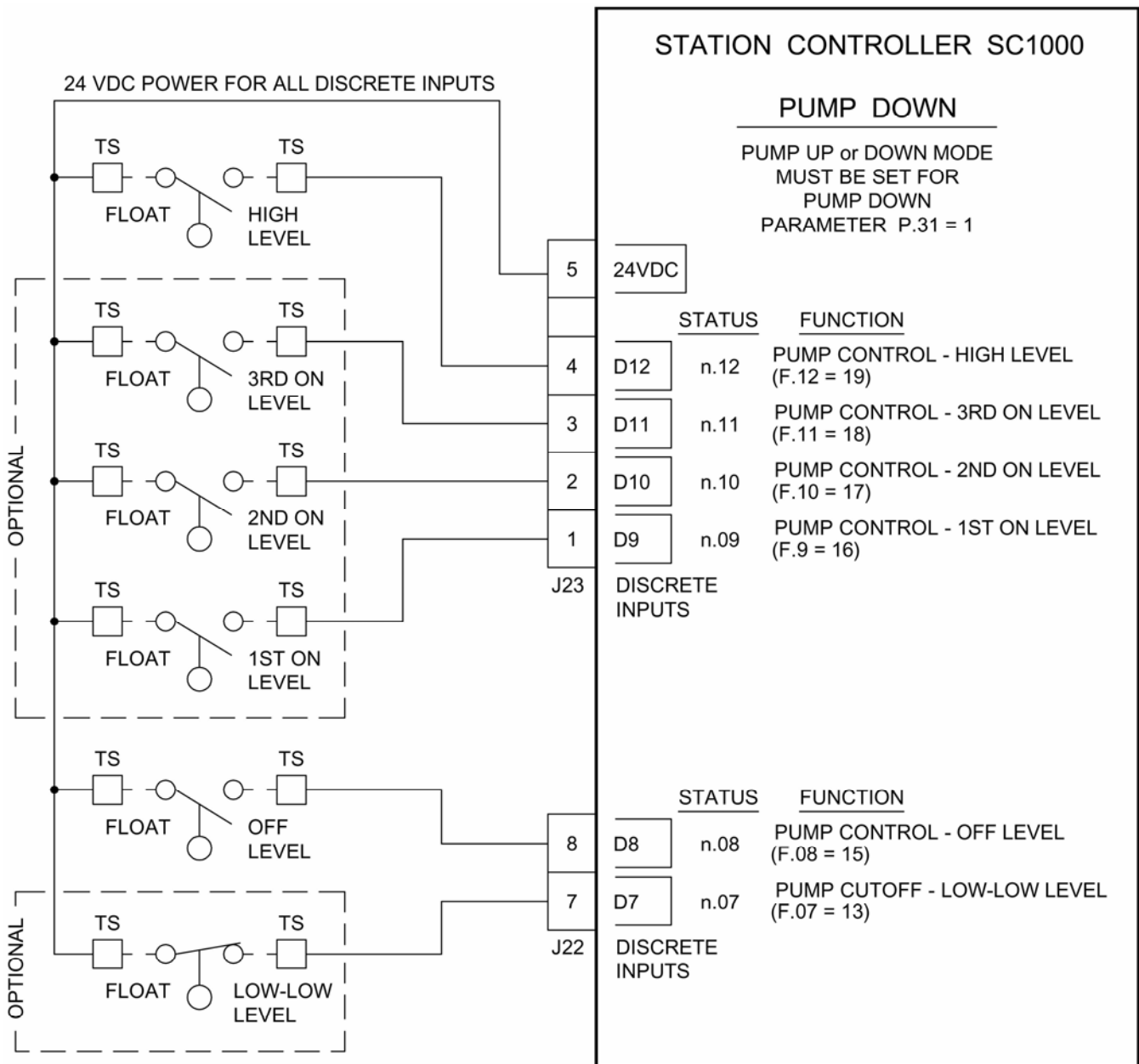

# FLOAT CONTROL - PUMP DOWN

The Float Control feature uses Float Switches as the primary and only level input.

For Float Control to be the primary and only means to control the pumps, the Level Input Select (Parameter P.22) must be set for Float Switch Inputs (Parameter P.22 = 3).

When Float Switches are used as the primary level input (Parameter P.22 = 3), all other level inputs (Transducer, Level Probe and Remote Control Input) are ignored and not used to call pumps to run.

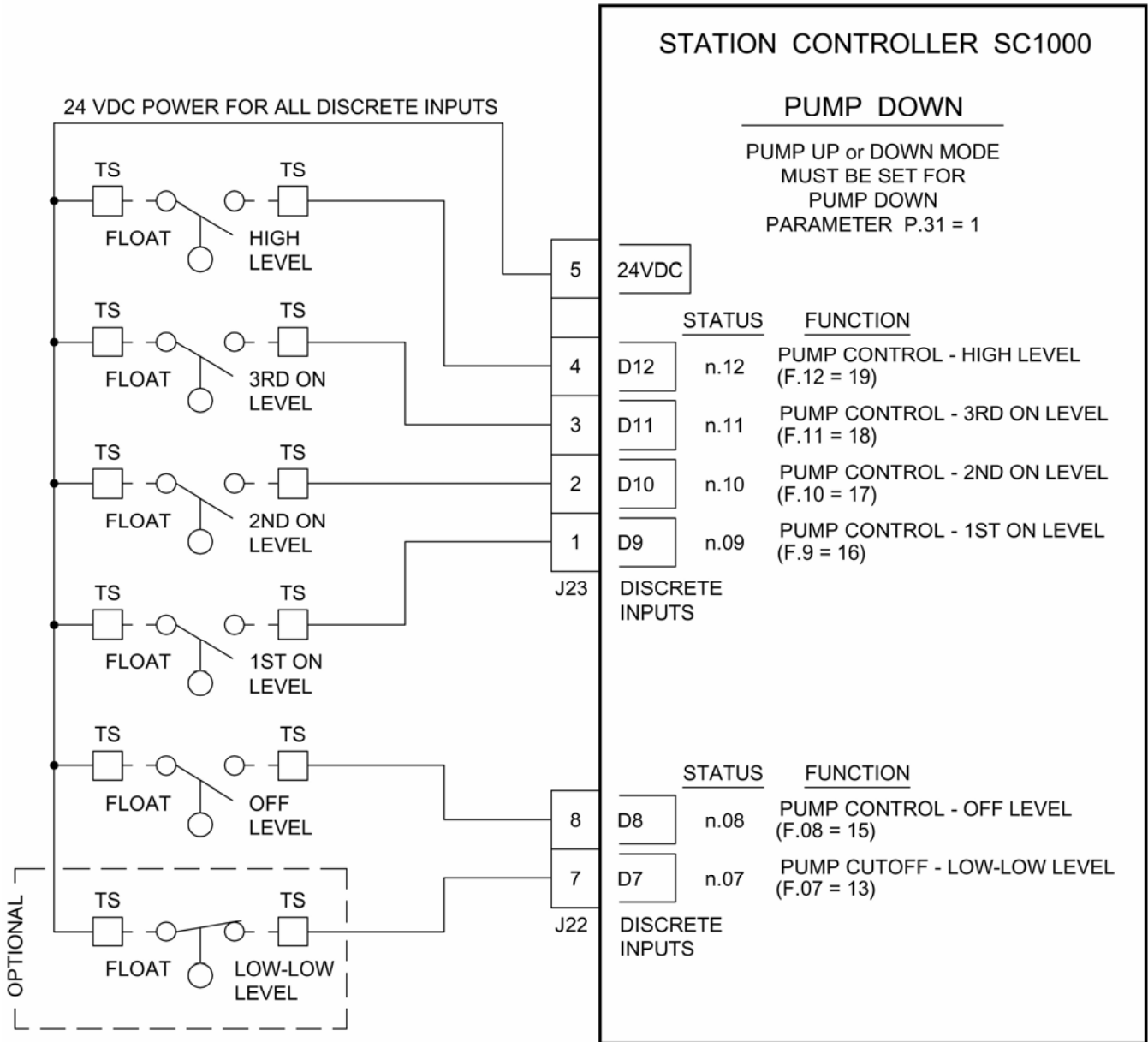

# FLOAT BACKUP or FLOAT CONTROL - PUMP UP

