

SC1000

INSTRUCTION MANUAL



MOTOR PROTECTION ELECTRONICS, INC.

**2464 Vulcan Road
Apopka, Florida 32703**

**Phone: (407) 299-3825
Website: www.mpelectronics.com**

STATION CONTROLLER SC1000

APPLICATIONS

- Simplex, Duplex, or Triplex Liquid Level Control
- Pump Down (Empty a Tank) or Pump Up (Fill a Tank)
- Where Connection to a SCADA System is Required

STANDARD FEATURES

- All Setup Parameters Values may be viewed or changed from the front of the unit
- Level Input Source - Menu Selectable:
 - Analog Level Input [4-20mA from Pressure Transducer]
 - Level Probe [Conductance Probe with 10 Electrodes]
- Regulated +20VDC power for Analog Level Input
- RS-232 Serial Port with Modbus RTU Protocol
- High and Low Level Alarm Relays and Alarm Indication
- Adjustable Lag Pump(s) Delay
- Alternation Schemes - Menu Selectable:
 - Standard Alternation
 - Pump 1 Always Lead - Stays On with other Pumps
 - Pump 1 Always Lead - Turns Off with other Pumps On
 - Split Alternation - Pumps 1&2, and Pumps 3 Always Last
 - Fixed Sequence - Pump 1 Always Lead
 - Stepped On/Off - Only One Pump Runs at a TimeAlternator Logic Skips Disabled Pumps
First On - First Off or First On - Last Off Alternation
- Level Simulation (Automatically ends after 1 minute)
- 12 Discrete Inputs programmable for the following functions:
 - Pump disable with HOA in OFF, or pump fault
 - External Lead Pump Selector Switch
 - All pump disable - for connection to Phase Monitor
 - Limit number of pumps called while on emergency power
 - Alternation by External Time Clock
 - Freeze wet well level during a bubbler tube purge
 - Float switch backup
 - Low Level Pump Cutoff
 - Start Flush Cycle
 - A variety of SCADA functionsStatus of Discrete Inputs may be viewed from front of Controller
- Backup Control, and High & Low Alarms using a Level Probe
- Output Relays may be programmed for control through SCADA
- Automatic Flush Cycle to reduce sludge build up
- Flow Calculator that provides the following Flow Data:
 - Latest Inflow Rate
 - Average Daily Inflow Total (Average of Last 7 Days)
 - Pump Outflow Rate (Latest for Each Pump)

OPTIONAL FEATURES

- 4-20mA Analog Level Input may be ordered as an Isolated Input
- Ethernet Port with the following protocols:
Modbus TCP or Modbus RTU

SPECIFICATIONS

- Input Power: 120 VAC $\pm 10\%$, 13 VA max
- External Dimensions: 6.9" x 8.5" x 4.1"
- Agency Approvals: UL 508, CAN/CSA
- Ambient Operating Temperature:
-20°C to +65°C (-4°F to +149°F)
- Level Display: 3 Digit, 7 Segment LED
- Level Display Range: 0 - 999 feet
(Decimal Point Position is Selectable)
- Indicators: LED
- Color: White with Blue Lettering
- Relays: 6A @ 250VAC
- Analog Level Input: 4-20mA, 250 Ω Load, Transient Protected
- Level Probe Inputs: $\pm 8V$, 60Hz Square Wave, $\pm 0.8mA$ max, Transient Protected
- Discrete Inputs: 24VDC, Transient Protected
- Power for Discrete Inputs: Unregulated +24VDC, Transient Protected
- Power for Analog Level Input: Regulated +20VDC $\pm 1V$, Transient Protected

ORDERING INFORMATION

Part Number: SC1000 - X X

Blank = RS232 Port
E = RS232 Port & Ethernet Port

Blank = Non-Isolated Analog Level Input
S = Isolated Analog Level Input

OPERATOR INTERFACE FUNCTIONS

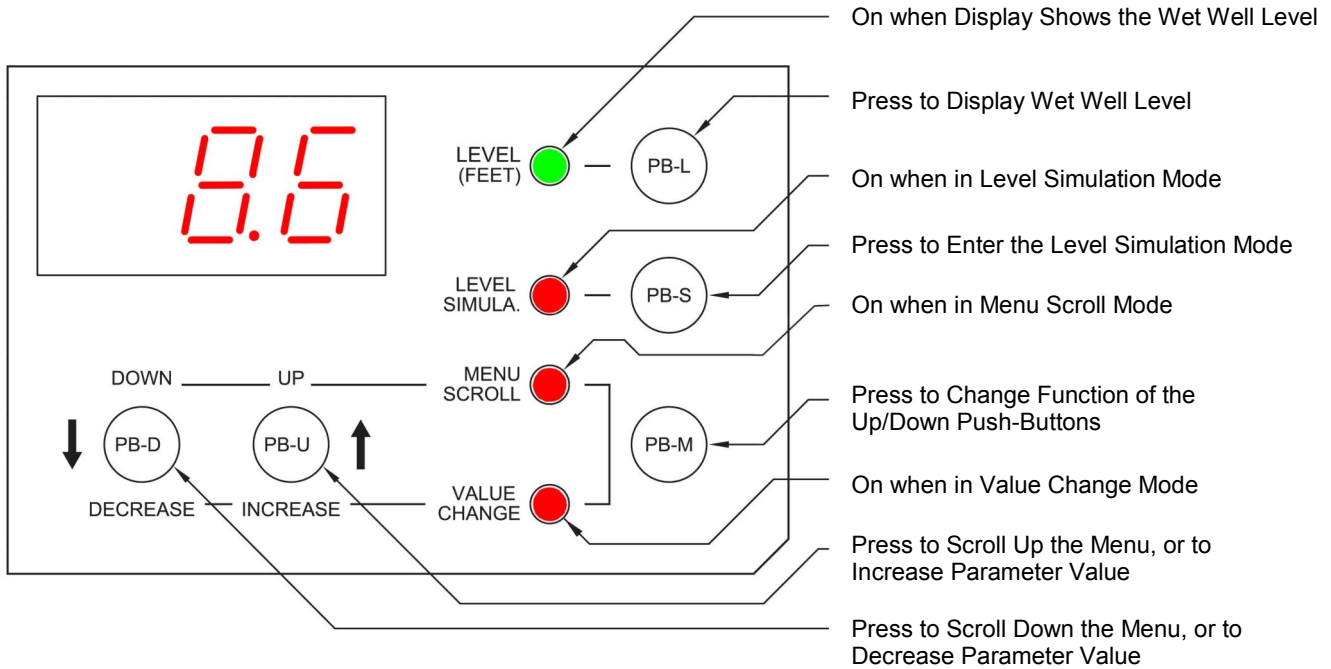

Note: There is a 4 second Delay on Changing Parameter Values.

How to View a Setup Parameter Value

1. Press push-button PB-M until the Menu Scroll Mode indicator comes on.
2. Press push-button PB-D or PB-U as needed to arrive at the Parameter you wish to view.

3. Parameters Shown on Front of Controller:
The value of the Parameter is displayed whenever the indicator next to the Parameter label is on.

Parameters in the System Setup Sub-Menu:
The value of a Parameter in the System Setup Sub-Menu may be viewed by using the push-button PB-M to toggle from the Parameter number (P.13, for example) to the Parameter value.

How to Change a Setup Parameter Value

1. Press push-button PB-M until the Menu Scroll mode indicator comes on.
2. Press push-button PB-D or PB-U as needed to arrive at the Parameter you wish to change.

3. Parameters Shown on Front of Controller:
Press push-button PB-M until the Value Change indicator comes on.

Parameters in the System Setup Sub-Menu:
Press push-button PB-M until the Value Change indicator comes on. The current value of the Parameter will then be displayed.

4. Press and hold for 4 seconds, either push-button PB-D or PB-U, to change the Parameter to the desired new value.
5. Press push-button PB-M or PB-L to exit the Value Change mode.

How to Simulate Levels

1. Press push-button PB-S.
Note: The Simulation starts from the actual level displayed prior to entering the Level Simulation mode.
2. Press push-button PB-D or PB-U as needed to change the simulated level.
3. To end the level simulation press push-button PB-L.
Note: If you do not exit the Level Simulation mode, normal operation will resume automatically 60 seconds after the last time the PB-U, PB-D, or PB-S push-buttons were pressed.

MENU - SYSTEM SETUP

All Level Settings Have the Decimal Point Artificially Inserted Based on Parameter P.36.

Parameter	Default Value	Current Value	Setting Definitions
-	2.0 feet		Low Level Alarm SCADA Register 40021 Range: 0.1 - 99.9 feet Note: To Disable Alarm see Parameter P.50.
-	3.0 feet		1st Pump Off Level SCADA Register 40013 Range: 0.2 - 99.9 feet
-	6.0 feet		1st Pump On Level SCADA Register 40012 Range: 0.2 - 99.9 feet
-	4.0 feet		2nd Pump Off Level SCADA Register 40015 Range: 0.2 - 99.9 feet
-	7.0 feet		2nd Pump On Level SCADA Register 40014 Range: 0.2 - 99.9 feet
-	4.5 feet		3rd Pump Off Level SCADA Register 40017 Range: 0.2 - 99.9 feet
-	8.0 feet		3rd Pump On Level SCADA Register 40016 Range: 0.2 - 99.9 feet
-	10.0 feet		High Level Alarm SCADA Register 40020 Range: 0.5 - 99.9 feet
P.12	5 sec.		Lag Pump(s) Delay Range: 1 - 100 seconds
P.13	3		Number of Pumps Present See Page 9. 1 = 1 Pump 2 = 2 Pumps 3 = 3 Pumps
P.14	3		Number of Pumps Allowed to Run at the Same Time See Page 9. 1 = 1 Pump 2 = 2 Pumps 3 = 3 Pumps
P.15	3		Number of Pumps Allowed to Run On Generator See Page 9. 1 = 1 Pump 2 = 2 Pumps 3 = 3 Pumps Note: Must Connect Transfer Switch Contacts to Discrete Input Programmed for Function 6.
P.16	1		Alternator Sequence Mode See Page 11. 1 = Standard Alternation See Page 11. 2 = Pump 1 Always Lead - Stays On With Other Pumps See Page 12. 3 = Pump 1 Always Lead - Turns Off With Other Pumps See Page 12. 4 = Split Alternation - Pumps 1&2, and Pump 3 Always Last See Page 13. 5 = Fixed Sequence - Pump 1 Always Lead See Page 13. 6 = Stepped On/Off - Only One Pump Runs at a Time See Page 13.
P.17	2		Pump Stop Mode See Page 10. 1 = First On Last Off 2 = First On First Off
P.18	1		Automatic Alternation See Page 10. 1 = Enabled 2 = Disabled
P.19	1		Pump Up or Down Mode 1 = Pump Down - Empty a Tank 2 = Pump Up - Fill a Tank Note: When Parameter P.19 is Changed New Default Level Parameter Values will be loaded.
P.24	11.5 feet		Level Input Calibration - Span Range: 0.9 - 99.9 feet See Page 20. Notes: 1. 20mA is Typically Applied to the Analog Input while Setting the Span. 2. Parameter P.24 Shows the Wet Well Level, while allowing the Up & Down Push-buttons to Change the Internal Number used to Calculate the Displayed Level. 3. When Controller is set to Operate using a Level Probe, Parameter P.24 shows "77.7".
P.25	0.0 feet		Level Input Calibration - Zero See Page 20. Notes: 1. 4.0mA is Typically Applied to the Analog Input while Setting the Zero. 2. Parameter P.25 Shows the Wet Well Level, while allowing the Up & Down Push-buttons to Change the Internal Number used to Zero the Displayed Level. 3. When Controller is set to Operate using a Level Probe, Parameter P.25 shows "77.7".
P.28	1		Slave Address See Page 24.
P.29 - P.32	-		RS232 Serial Port Setup See Page 25.

MENU - SYSTEM SETUP

All Level Settings Have the Decimal Point Artificially Inserted Based on Parameter P.36.

Parameter	Default Value	Current Value	Setting Definitions
P.33	1		Register Access Mode See Page 24.
P.35	1 sec.		Stop Pump Delay Range: 1 - 100 seconds Note: This is the Time Period that the Wet Well Level Must Remain At or Below (At or Above for Pump Up P.19 = 2) the Respective OFF Level Setting in order to Turn Off a Pump.
P.36	1		Display Decimal Point Position 0 = No Decimal Point 1 = XX.X 2 = X.XX
P.37	1 min.		Pump Re-enable Delay after Float Backup Low Level (High Level) Notes: Range: 1 - 255 minutes 1. Pump Down (Parameter P.19 = 1) - Delay Starts when the Low Level Float Input Opens. 2. Pump Up (Parameter P.19 = 2) - Delay Starts when the High Level Float Input Opens.
P.38	1 min.		Delay Canceling Remote Control Commands Notes: Range: 1 - 254 minutes 1. Delay Starts when Serial Communication is Lost. 2. To Allow all Remote Commands to Remain in Effect (Until Power Loss) Set P.38 = 255.
P.39	0		Forced Lead Pump Position SCADA Register 40022 See Page 10. 0 = Normal Alternation 1(2,3) = Pump 1(2,3) as Lead
P.40 - P.43	-		Flush Cycle Setup See Page 21.
P.44 - P.47	-		Flow Calculator Setup See Pages 22 - 23.
P.49	240		Analog Level Input - Signal Conditioning Control Range: 1 - 254 10 = Very Slow 100 = Slow 240 = Normal 250 = Fast
P.50	1		Low Level Alarm Mode 0 = Disabled 1 = Enabled Note: Setting "0" Disables Low Level Alarms from the Analog Level Input or Level Probe Inputs.
P.51	0		Time Based Alternation Range: 1 - 255 1/6 hour See Page 10. 0 = Disabled 1 = 1/6 hour 6 = 1 hour 48 = 8 hours 144 = 24 hours
P.52	0		Pump 1 (2,3) Disable - Discrete Input Mode 0 = Normal 1 = Logic Inverted
FLC	-		Fault Code SCADA Register 40047 See Fault Code Table on Pages 18 -19. Note: This Automatically Returns to Zero when the Fault Clears (Except for Faults 20-29).
LFC	-		Last Fault Code SCADA Register 40048 See Fault Code Table on Pages 18 -19. Note: This is a Copy of the Last Non-Zero Fault Code that was shown on Parameter FLC.
oPr	-		Operating Program Revision Number - Controller SCADA Register 40063
EPr	-		Operating Program Revision Number - Ethernet Board

MENU - SYSTEM SETUP

All Level Settings Have the Decimal Point Artificially Inserted Based on Parameter P.36.

Parameter	Default Value	Current Value	Setting Definitions
F.01	1		Discrete Input 1 Function
F.02	2		Discrete Input 2 Function
F.03	3		Discrete Input 3 Function
F.04	4		Discrete Input 4 Function
F.05	5		Discrete Input 5 Function
F.06	6		Discrete Input 6 Function
F.07	7		Discrete Input 7 Function
F.08	8		Discrete Input 8 Function
F.09	9		Discrete Input 9 Function
F.10	10		Discrete Input 10 Function
F.11	11		Discrete Input 11 Function
F.12	12		Discrete Input 12 Function
<p>Function of Input:</p> <p>0 = No Function</p> <p>1 = Pump 1 Disable HOA and Fault Logic</p> <p>2 = Pump 2 Disable HOA and Fault Logic</p> <p>3 = Pump 3 Disable HOA and Fault Logic</p> <p>4 = Level Freeze Bubbler Tube Purge Logic</p> <p>5 = External Alternation External Time Clock</p> <p>6 = On Generator Automatic Transfer Switch</p> <p>7 = All Pump Disable Phase Monitor</p> <p>8 = Sequence Input 1 Lead Select Switch - 1 as Lead</p> <p>9 = Sequence Input 2 Lead Select Switch - 2 as Lead</p> <p>10 = Sequence Input 3 Lead Select Switch - 3 as Lead</p> <p>11 = Low Level Alarm Low Level Float Switch</p> <p>12 = High Level Alarm High Level Float Switch</p> <p>13 = Telemetry E Telemetry Contact</p> <p>14 = Telemetry F Telemetry Contact</p> <p>15 = Telemetry G Telemetry Contact</p> <p>16 = Telemetry J Telemetry Contact</p> <p>17 = Telemetry K Telemetry Contact</p> <p>18 = Telemetry L Telemetry Contact</p> <p>19 = Telemetry A Telemetry Contact</p> <p>20 = Telemetry B Telemetry Contact</p> <p>21 = Telemetry C Telemetry Contact</p> <p>22 = Telemetry D Telemetry Contact</p> <p>23 = Normal Pump Operation Disable Fault Contact</p> <p>24 = Float Backup – Low Level Low Level Float Switch</p> <p>25 = Float Backup – Off Level Off Level Float Switch</p> <p>26 = Float Backup – 1ST On Level 1ST On Level Float Switch</p> <p>27 = Float Backup – 2ND On Level 2ND On Level Float Switch</p> <p>28 = Float Backup – 3RD On Level 3RD On Level Float Switch</p> <p>29 = Float Backup – High Level High Level Float Switch</p> <p>30 = Start Flush Cycle External Time Clock</p> <p>Connect To:</p>			
<p>Notes:</p> <ol style="list-style-type: none"> Function of Discrete Inputs may be set to "0" when Input is used only to collect data for SCADA and no other Function is desired. All Discrete Inputs may be read from SCADA Registers 40035 - 40037, regardless of the Function assigned to the Input. See pages 14 - 16 for description of each of the above Functions. Pump 1(2,3) Disable logic may be inverted. See Parameter P.52. 			
F.19	1		<p>Level Input Source</p> <p>1 = Analog Level Input (4-20mA) on J21</p> <p>2 = Level Probe Input on J25</p> <p>3 = Level Probe Input on J25 (Flashes Level Probe Electrode No. of Level Settings.)</p> <p>4 = Remote Level Input (Follows the Level written to SCADA Register 40025.)</p> <p>Note: Level Probe not suitable for applications measuring Storm Water or Well Water.</p>
F.20	12 inch		<p>Level Probe Electrode Spacing</p> <p>Range: 3 - 24 inches</p>
F.21	0.0 feet		<p>Level Offset</p> <p>Range: 0.0 - 5.0 feet</p> <p>Note: This adds to the level from the Analog Level Input or Level Probe Input.</p>
F.22	100		<p>Level Probe Sensitivity</p> <p>Range: 90 - 210</p> <p>100 = Typical Sewage 150 = Light Sewage</p> <p>Check value of Parameter L.10 with Electrode 10 covered, add 40 to it, and enter value for F.22.</p> <p>Note: Level Probe not suitable for applications measuring Storm Water or Well Water.</p>

MENU - SYSTEM SETUP

Parameter	Default Value	Current Value	Setting Definitions
F.31	1		HI Relay Output Function 0 = Disabled 1 = High Level Alarm 2 = Remote Control (SCADA Coil 25) Note: High Level indicator on front of unit will operate regardless of setting.
F.32	1		LO Relay Output Function 0 = Disabled 1 = Low Level Alarm 2 = Remote Control (SCADA Coil 26) Note: Low Level indicator on front of unit will operate regardless of setting.
F.33	1		P1 Relay Output Function 0 = Disabled 1 = Pump 1 Call 2 = Remote Control (SCADA Coil 27) Note: When set on "0" or "2" Pump 1 will be skipped over in all Alternation Sequence Modes.
F.34	1		P2 Relay Output Function 0 = Disabled 1 = Pump 2 Call 2 = Remote Control (SCADA Coil 28) Note: When set on "0" or "2" Pump 2 will be skipped over in all Alternation Sequence Modes.
F.35	1		P3 Relay Output Function 0 = Disabled 1 = Pump 3 Call 2 = Remote Control (SCADA Coil 29) Note: When set on "0" or "2" Pump 3 will be skipped over in all Alternation Sequence Modes.
E.01 - E.62	-		Ethernet Port Setup See Page 26.
			Level Probe Backup Functions
b.01	0		Low Level Alarm
b.02	0		Pump Control – Off Level
b.03	0		Pump Control – 1ST On Level
b.04	0		Pump Control – 2ND On Level
b.05	0		Pump Control – 3RD On Level
b.06	0		High Level Alarm
0 = Function Not Used 1 = Electrode Input 1 on Connector J25-1 2 = Electrode Input 2 on Connector J25-2 3 = Electrode Input 3 on Connector J25-3 4 = Electrode Input 4 on Connector J25-4 5 = Electrode Input 5 on Connector J25-5 6 = Electrode Input 6 on Connector J25-6 7 = Electrode Input 7 on Connector J25-7 8 = Electrode Input 8 on Connector J25-8 9 = Electrode Input 9 on Connector J25-9 10 = Electrode Input 10 on Connector J25-10			
Notes For Level Probe Backup Functions: For status of Level Probe inputs see Coils 583 - 592 in SCADA Register 40037.			
1. When the controller is set up to follow a 10 Electrode Conductance Level Probe as the primary level input source (Parameter F.19 = 2 or 3), the backup functions described here are not needed and will not operate.			
2. If a Function (such as Pump Control – 3RD On Level) is not desired set the respective parameter equal to zero.			
3. An effective Backup Pump Control would involve having a 3 point Level Probe placed high in the wet well. The Level Probe would be connected to Connector J25 terminals 1, 2, and 3. The Off Level should be made to operate from the bottom Electrode by setting Parameter b.02 = 3. The 1ST On Level should be set to operate from Electrode 2 by setting Parameter b.03 = 2. The 2ND On Level should be set to operate from Electrode 1 by setting Parameter b.04 = 1. If pump three is present set the 3RD On Level to operated from Electrode 1 by setting Parameter b.05 = 1.			
4. If a Backup High Level Alarm is desired, set Parameter b.06 to the number of the Electrode Input that the High Level Probe is connected to. This feature is for alarm and telemetry only and will not function as a redundant pump call. See SCADA notes page 31.			
5. If a Backup Low Level Alarm is desired, set Parameter b.01 to the number of the Electrode Input that the Low Level Probe is connected to. This feature is for alarm and telemetry only and will not function as a redundant pump off. See SCADA notes page 31.			
6. Whenever the Backup Pump Control is active the Fault indicator will be on and Fault Code of 30 will be present in Parameter FLC, and set Coil 15 in SCADA Register 40001.			

MENU - DATA DISPLAY

Parameter	Data Description	
L.01	Electrode 1 Status Value	<p>Level Probe Electrode Status Values</p> <p>Normal Range when Un-Covered: 240 - 255</p> <p>Normal Range when Covered by Typical Sewage: 55 - 70</p> <p>Notes:</p> <ol style="list-style-type: none"> The Controller compares each of the Electrode Status Values with what is set on Parameter F.22. When the value drops below the setting on Parameter F.22, the Controller logic considers the Electrode to be covered by liquid. Parameters L.01 - L.10 are also used to diagnose Out of Sequence Faults (Fault Codes 21 - 29). For the status of the Level Probe inputs see Coils 583 - 592 in SCADA Register 40037.
L.02	Electrode 2 Status Value	
L.03	Electrode 3 Status Value	
L.04	Electrode 4 Status Value	
L.05	Electrode 5 Status Value	
L.06	Electrode 6 Status Value	
L.07	Electrode 7 Status Value	
L.08	Electrode 8 Status Value	
L.09	Electrode 9 Status Value	
L.10	Electrode 10 Status Value	
L.11	Level Probe Test Signal Status	<p>Normal Range: 230 - 254</p> <p>Note: This is a Measure of the $\pm 8V$, 60Hz Square Wave Sent Out to Each Electrode to read the level. If the value is below 210, a malfunction has occurred in the circuit that provides the Square Wave used to read the level. In this case the wet well level display will show zero, the Fault indicator will be turned on, and Fault Code 20 will be generated.</p>
FLH	Flow Calculator - Latest Inflow Rate	FLH , FLL Gallons Per Minute
FLL	See Pages 22 - 23.	SCADA Register 40080
FdH	Flow Calculator - Average Daily Inflow Total	FdH , FdL Units set by Parameter P.45.
FdL	See Pages 22 - 23.	SCADA Register 40081
F1H	Flow Calculator - Pump 1 Outflow Rate	F1H , F1L Gallons Per Minute
F1L	See Pages 22 - 23.	SCADA Register 40082
F2H	Flow Calculator - Pump 2 Outflow Rate	F2H , F2L Gallons Per Minute
F2L	See Pages 22 - 23.	SCADA Register 40083
F3H	Flow Calculator - Pump 3 Outflow Rate	F3H , F3L Gallons Per Minute
F3L	See Pages 22 - 23.	SCADA Register 40084

MENU - DATA DISPLAY

Parameter	Data Description		
n.01	Discrete Input 1 Status	Discrete Input Status 0 = Input Open 1 = Input Closed Notes: 1. Discrete Input Status is used when troubleshooting the wiring and logic connected to the Discrete Inputs. 2. Discrete Input Status data may be read by SCADA at Registers 40035 - 40036. See Page 28.	
n.02	Discrete Input 2 Status		
n.03	Discrete Input 3 Status		
n.04	Discrete Input 4 Status		
n.05	Discrete Input 5 Status		
n.06	Discrete Input 6 Status		
n.07	Discrete Input 7 Status		
n.08	Discrete Input 8 Status		
n.09	Discrete Input 9 Status		
n.10	Discrete Input 10 Status		
n.11	Discrete Input 11 Status		
n.12	Discrete Input 12 Status		
d.01	Voltage of +5 Volt Power Supply	SCADA Register 40049	Normal Range: 8.5V - 11.3V Note: Voltage is measured ahead of Voltage Regulator.
d.02	Voltage of +24 Volt Power Supply	SCADA Register 40050	Normal Range: 21.1V - 25.5V
d.07	Serial Communication Activity Indicator	See Page 33.	
d.08	Serial Communication – Shows the Address of the Last Slave Polled by the Master.	See Page 33.	
d.09	Serial Communication – Shows the Last Modbus Function Code Received.	See Page 33.	
d.10-d.86	Serial Communication – Shows the Entire Rest of the Last Modbus Message Received.		

PUMP CALL SEQUENCE - Setup Parameters

Pump Stop Mode - Parameter P.17

This Parameter establishes which pump is the next one to be stopped, when there are two or more pumps on.

The Controller has a corresponding "Pump Off Level" setting for each of the "Pump On Level" settings. For the "Pump Stop Mode" feature to operate, the "Pump Off Level" settings must be set on different levels. If all the "Pump Off Level" settings are set on the same level it does not matter what Parameter P.17 is set on.

First On Last Off - In this mode, as the level reaches one of the "Pump Off Level" settings, the pump that was most recently turned on is turned off, leaving the one that was call to run first still running.

First On First Off - In this mode, as the level reaches one of the "Pump Off Level" settings, the pump that was most recently turned on is left on and the pump that has been on the longest is turned off. This results in a longer cool down period for each pump between starts. This mode works the best in stations where one pump is required to run for a long period of time, with an occasional need for an additional pump.

Parameter	Default Value	Setting Definitions
P.17	2	Pump Stop Mode 1 = First On Last Off 2 = First On First Off

Automatic Alternation - Parameter P.18

This Parameter is provided so that normal automatic alternation may be disabled (turned off). Typically, normal alternation is disabled only in applications that have an external Time Clock used to alternated the pumps.

(The Time Clock would be connected to a Discrete Input programmed for "External Alternation" , Function 5.)

Parameter	Default Value	Setting Definitions
P.18	1	Automatic Alternation 1 = Enabled 2 = Disabled

Forced Lead Pump Position - Parameter P.39

This Parameter is provided so that a fixed sequence may be established with the selected pump always as lead.

For example setting Parameter P.39 on 1 will cause a fixed pump call sequence of 1-2-3. Parameter P.39 may also be changed by writing a 0,1,2, or 3 to SCADA Register 40022.

Parameter	Default Value	Setting Definitions
P.39	0	Forced Lead Pump Position SCADA Register 40022 0 = Normal Alternation 1(2,3) = Pump 1(2,3) as Lead

Time Based Alternation - Parameter P.51

This feature may be used to ensure that alternation periodically occurs even in applications that tend to run one pump for a long period of time. The internal Time Clock starts and runs whenever at least one pump is called to run. When it times out, it forces the alternation of the pumps and then resets the Time Clock. The Time Clock is also reset each time a Normal Alternation Occurs.

Parameter	Default Value	Setting Definitions
P.51	0	Time Based Alternation Time Clock Range: 1 - 255 1/6 hour 0 = Disabled 1 = 1/6 hour 6 = 1 hour 48 = 8 hours 144 = 24 hours

ALTERNATION SEQUENCE MODE

STANDARD ALTERNATION

Parameter P.16 = 1

Notes:

1. Unless there is some special circumstance that requires a more complicated pump call sequence, this is the sequence that should be used.
2. Parameter P.17 must be used to select either First On Last Off or First On First Off.
3. Discrete Inputs programmed as Pump 1-3 Disable inputs may be used to disable pumps.
4. Discrete Inputs programmed as Sequence Inputs 1-3 may be used to set the lead pump.
5. Parameter P.39 may be used to set the lead pump.
6. A Discrete Input programmed for External Alternation (Function 5) may be used to force alternation. When this feature is used, Automatic Alternation would normally be disabled by setting Parameter P.18 to Disabled.
7. If connected to a SCADA system, alternation may be initiated by momentarily setting Coil 136, or by forcing the lead pump by writing to Register 40022 (Same as Parameter P.39).
8. Parameter P.51 may be used to select and setup Time Based Alternation.

Movement of Lead Pump Upon Alternation

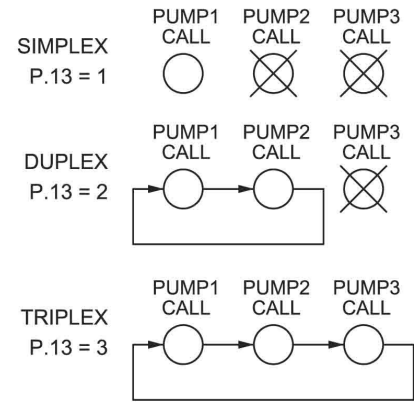

= Never Called To Run

PUMP 1 ALWAYS LEAD Stays On With Other Pumps

Parameter P.16 = 2

Notes:

1. This sequence is used when it is required that pump 1 always be lead pump. This sequence keeps pump 1 on, when the other pumps are called to run.
2. Parameter P.17 must be used to select either First On Last Off or First On First Off.
3. Discrete Inputs programmed as Pump 1-3 Disable inputs may be used to disable pumps.
4. For Triplex applications Discrete Inputs programmed as Sequence Inputs 2-3 may be used to set the lead pump.
5. For Triplex applications Parameter P.39 may be used to set the lead pump among pumps 2 and 3.
6. If pump 1 is disabled another pump will be called in its place.
7. A Discrete Input programmed for External Alternation (Function 5) may be used to force alternation. When this feature is used, Automatic Alternation would normally be disabled by setting Parameter P.18 to Disabled.
8. If connected to a SCADA system, alternation may be initiated by momentarily setting Coil 136, or by forcing the lag pump by writing to Register 40022 (Same as Parameter P.39).
9. Parameter P.51 may be used to select and setup Time Based Alternation.

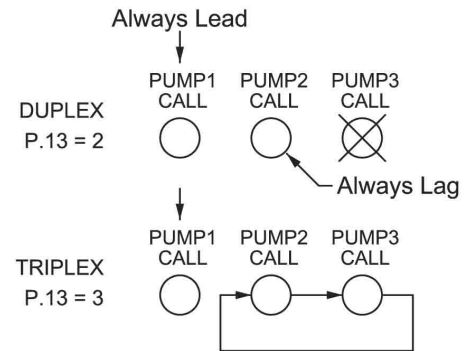

ALTERNATION SEQUENCE MODE

PUMP 1 ALWAYS LEAD Turns Off With Other Pumps On

Parameter P.16 = 3

Notes:

1. This sequence is used when it is required that pump 1 always be lead, and when it must be turned off when another pump(s) comes on. When a pump from the second group is required, pump 1 is first turned off, then after the Lag Pump Delay, the other pump is turned on.
2. For Triplex applications Parameter P.17 must be used to select either First On Last Off or First On First Off.
3. Discrete Inputs programmed as Pump 1-3 Disable inputs may be used to disable pumps.
4. For Triplex applications Discrete Inputs programmed as Sequence Inputs 2-3 may be used to set the lead pump.
5. For Triplex applications Parameter P.39 may be used to set the lead pump among pumps 2 and 3.
6. If pump 1 is disabled, another pump will Not be called in its place. The 1ST Pump On/Off Level parameters are dedicated to pump 1 and will not call another pump.
7. A Discrete Input programmed for External Alternation (Function 5) may be used to force alternation. When this feature is used, Automatic Alternation would normally be disabled by setting Parameter P.18 to Disabled.
8. If connected to a SCADA system, alternation may be initiated by momentarily setting Coil 136, or by forcing the lag pump by writing to Register 40022 (Same as Parameter P.39).
9. Parameter P.51 may be used to select and setup Time Based Alternation.

Movement of Lead Pump Upon Alternation

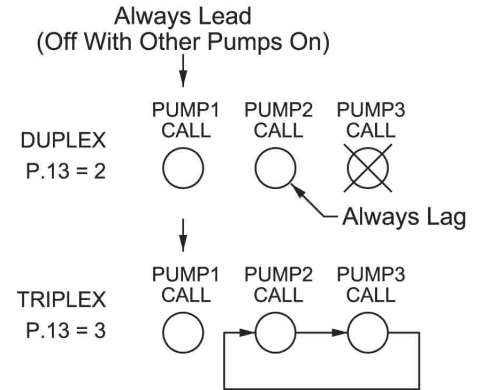

= Never Called To Run

SPLIT ALTERNATION

Parameter P.16 = 4

Notes:

1. This sequence is used when it is required that pumps 1 and 2 alternate among themselves and pump 3 must always be called last.
2. For Triplex applications Parameter P.17 must be used to select either First On Last Off or First On First Off.
3. Discrete Inputs programmed as Pump 1-3 Disable inputs may be used to disable pumps.
4. Discrete Inputs programmed as Sequence Inputs 1-2 may be used to set the lead pump.
5. Parameter P.39 may be used to set the lead pump. Setting Parameter P.39 on 3 has no effect.
6. If either Pump 1 or 2 is disabled, then Pump 3 will be called to take its place.
7. A Discrete Input programmed for External Alternation (Function 5) may be used to force alternation. When this feature is used, Automatic Alternation would normally be disabled by setting Parameter P.18 to Disabled.
8. If connected to a SCADA system, alternation of Pumps 1 and 2 may be initiated by momentarily setting Coil 136, or by forcing the lead pump position by writing to Register 40022 (Same as Parameter P.39).
9. Parameter P.51 may be used to select and setup Time Based Alternation.

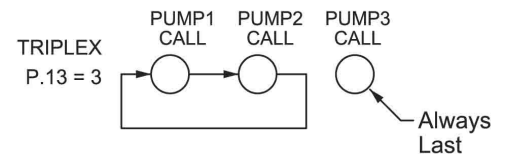

ALTERNATION SEQUENCE MODE

FIXED ALTERNATION

Parameter P.16 = 5

Notes:

1. This sequence is used when no alternation is required and when pump 1 should normally be lead pump. Other pumps may be made lead by setting Parameter P.39.
2. Discrete Inputs programmed as Pump 1-3 Disable inputs may be used to disable pumps.
3. Discrete Inputs programmed as Sequence Inputs 1-3 may be used to set the lead pump.
4. Parameter P.39 may be used to set the lead pump.
5. The Pump Stop Mode (Parameter P.17) has no effect on this sequence.
6. Automatic Alternation Enable/Disable (Parameter P.18) has no effect on this sequence.
7. The External Alternation feature will not function when using this sequence.
8. If connected to a SCADA system, the lead pump position may be set by writing to Register 40022 (Same as Parameter P.39).
9. Time Based Alternation using Parameter P.51 will not function when using this sequence.

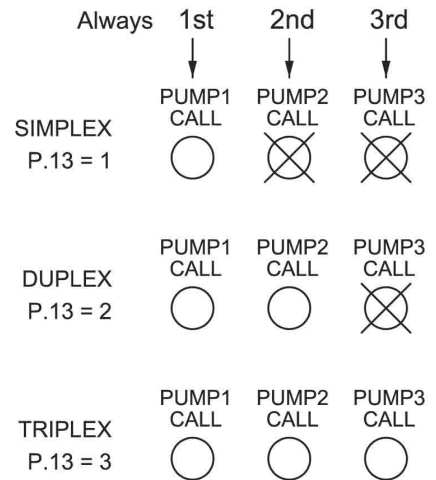

⊗ = Never Called To Run

STEPPED ON/OFF SEQUENCE Only One Pump Runs at a Time

Parameter P.16 = 6

Notes:

1. This sequence is used in stations where there is a significant difference in the size of the pumps, and when only one pump is to be allowed to run at a time. When there is a need for more pumping, the smaller pump is turned off and the next larger pump is called to run. As the need for pumping decreases, the larger pump is turned off and a smaller pump is called to run in its place (provided the Off Levels are staggered).
2. The Lag Pump Delay operates to give the check valve of the pump being turned off time to close before another pump is called to run.
3. Discrete Inputs programmed as Pump 1-3 Disable inputs should be used to disable pumps that are not able to run. It is critical that the largest pump in the group, have some type of pump fault logic connected to the respective Pump Disable discrete input.
4. Discrete Inputs programmed as Sequence Inputs 1-3 will not function when using this sequence.
5. Parameter P.39 has no effect on this sequence.
6. The Pump Stop Mode (Parameter P.17) has no effect on this sequence.
7. Automatic Alternation Enable/Disable (Parameter P.18) has no effect on this sequence.
8. The External Alternation feature will not function when using this sequence.
9. The On Generator (Parameter P.15) has no effect on this sequence.
10. Time Based Alternation using Parameter P.51 will not function when using this sequence.

DISCRETE INPUT FUNCTIONS

The following is a description of the Functions that may be assigned to the Discrete Inputs using Parameters F.01 - F.12:

- Notes:
1. All Discrete Inputs are originally programmed with default Functions, but they may be changed at any time using Parameters F.01 - F.12.
 2. Each of the Functions may only be assigned to one Discrete Input. If assigned to more than one input, the Fault indicator will come on and Fault Code 8 will be generated.

Pump 1 (2, 3) Disable - Functions 1 - 3

With Parameter P.52 = 0 (Normal Mode)

When a Discrete Input programmed as a "Pump 1 (2, 3) Disable" is **closed**, the respective pump will be disabled (not allowed to run) and skipped over in the pump call sequence.

With Parameter P.52 = 1 (Logic Inverted Mode)

When a Discrete Input programmed as a "Pump 1 (2, 3) Disable" is **open**, the respective pump will be disabled (not allowed to run) and skipped over in the pump call sequence.

Whenever a pump is disabled the next available pump is called in its place when needed. The one exception to this, is the Alternation Sequence - Pump 1 Always Lead (Parameter P.16 = 3), where disabling pump 1 will not result in another pump taking its place.

Level Freeze - Function 4

When a Discrete Input programmed for "Level Freeze" is first closed, the Wet Well Level is held steady or frozen so that a bubbler system's bubbler tube may be purge without causing the Level to jump up or down. The external logic that performs the bubbler tube purge must provide the Discrete Input closure prior to a significant change in the 4-20mA analog Level input. The Level Freeze logic keeps the Level frozen for 10 seconds and then releases it, regardless of whether the Discrete Input had re-opened or not. It does not matter how long the input remains closed, but it must be opened to reset the logic.

External Alternation - Function 5

Each time the Discrete Input programmed for "External Alternation" transitions from open to closed, alternation of the pumps will occur. It does not matter how long the input remains closed, but it must be opened to reset the logic. If no pumps were running when the Discrete Input is closed, the alternation of the designated lead pump will still occur. Typically this input is connected to contacts from an external Time Clock.

On Generator - Function 6

In cases where the Emergency Generator is not sized large enough to run all the available pumps, closing a Discrete Input programmed for "On Generator" will limit the number of pumps called to run to the number preset using Parameter P.15. Typically a contacts from the Transfer Switch are connected to this input.

All Pump Disable - Function 7

When a Discrete Input programmed for "All Pump Disable" is closed, all the pumps are disabled (not allowed to run), the Fault indicator will come on, the Power indicator will flash, and Fault Code 18 will be generated. This Function also disables pump operation from Float Backup using Functions 24 - 29, or Level Probe Backup using Parameters b.01 - b.06. The Discrete Input is typically connect to Phase Monitor contacts.

When the Discrete Input opens, the Lag Pump Delay must expire before the first pump is allowed to run. If any additional pumps are required, the Lag Pump Delay must expire between each one called to run.

Sequence Input 1 (2, 3) - Functions 8 - 10

When a Discrete Input programmed as a "Sequence Input 1 (2, 3)" is closed, it disables normal alternation and forces one of the pumps to always be lead pump. For example, closing "Sequence Input 1" forces pump 1 to be lead and sets the sequence of 1 - 2 - 3 (assuming Parameter P.16 = 1). See page 35 for connection diagrams.

DISCRETE INPUT FUNCTIONS

Low Level Alarm - Function 11

When a Discrete Input programmed for “Low Level Alarm” is closed, the Low Level indicator will come on and the Low Level Alarm relay contacts will close. This Function is for alarm and indication only and will not disable pump operation. Also see Function 24.

High Level Alarm - Function 12

When a Discrete Input programmed for “High Level Alarm” is closed, the High Level indicator will come on and the High Level Alarm relay contacts will close. This Function is for alarm and indication only and will not affect pump operation. Also see Function 29.

Telemetry E - D - Functions 13 - 22

When the Discrete Input(s) programmed for “Telemetry E-D” are closed, no control Function in the Controller is performed, only the status of the Discrete Inputs is placed in predetermined Coils in SCADA Registers 40001 and 40008. These Functions are used to assign any of the available Discrete Inputs to a specific Coil. See Page 27.

Normal Pump Operation Disable - Function 23

When a Discrete Input programmed for “Normal Pump Operation Disable” is closed, all the pumps are disabled (not allowed to run), the Fault indicator will come on, and Fault Code 15 will be generated. However, this Function does allow pump operation from Float Backup using Functions 24 - 29, or Level Probe Backup using Parameters b.01 - b.06.

This Function is used when it is required that a backup system have complete control of the pumps. The Discrete Input must be connected to contacts that closes when external logic determines that switching control of the pumps to the backup system is necessary.

Float Backup - Low Level - Function 24

When a Discrete Input programmed for “Float Backup - Low Level” is closed, the Low Level indicator will come on and the Low Level Alarm relay contacts will close. Also see Function 11.

Pump Down Mode (Parameter P.19 = 1)

All pump operation will be disabled when the “Float Backup - Low Level” input closes.

When the “Float Backup - Low Level” input opens the “Pump Re-enable Delay” (set using Parameter P.37), must expire before pump operation is allowed.

Pump Up Mode (Parameter P.19 = 2)

All available pumps will be called to run when the “Float Backup - Low Level” input closes, assuming that the “Float Backup - Off Level” input is closed.

See Page 38.

DISCRETE INPUT FUNCTIONS

Float Backup - Off Level - Function 25

When a Discrete Input programmed for “Float Backup - Off Level” closes, the Float Backup logic will be armed and made ready to latch in one pump call for each of the “Float Backup - 1st , 2nd, 3rd On Level” inputs that close.

As the “Float Backup - 1st , 2nd, 3rd On Level” inputs open, the pump calls remain latched until the Off Level input also opens, then the latch is broken on all the pump calls, and the pumps are turned off.

Note: For a two float backup system, the “Float Backup - 1st , 2nd, 3rd On Level” inputs may be replaced with the High Level input for the Pump Down mode, or the Low Level input for the Pump Up mode.

See Page 38.

Float Backup - 1st On Level - Function 26

When a Discrete Input programmed for “Float Backup - 1st On Level” closes, the Float Backup logic will issue one pump call assuming that the “Float Backup - Off Level” is closed. See Page 38.

Float Backup - 2nd On Level - Function 27

When a Discrete Input programmed for “Float Backup - 2nd On Level” closes, the Float Backup logic will issue one pump call assuming that the “Float Backup - Off Level” is closed. See Page 38.

Float Backup - 3rd On Level - Function 28

When a Discrete Input programmed for “Float Backup - 3rd On Level” closes, the Float Backup logic will issue one pump call assuming that the “Float Backup - Off Level” is closed. See Page 38.

Float Backup - High Level - Function 29

When a Discrete Input programmed for “Float Backup - High Level” is closed, the High Level indicator will come on and the High Level Alarm relay contacts will close. Also see Function 12.

Pump Down Mode (Parameter P.19 = 1)

All available pumps will be called to run when the “Float Backup - High Level” input closes, assuming that the “Float Backup - Off Level” input is closed.

Pump Up Mode (Parameter P.19 = 2)

All pump operation will be disabled when the “Float Backup - High Level” input closes.

When the “Float Backup - High Level” input opens the “Pump Re-enable Delay” (set using Parameter P.37), must expire before pump operation is allowed.

See Page 38.

Start Flush Cycle - Function 30

When a Discrete Input programmed for “Start Flush Cycle” closes, the Flush Cycle will start (assuming that the Flush Cycle Mode Parameter P.40 = 2). It does not matter how long the input remains closed, but it must be opened to reset the logic. Typically this input is connected to contacts from an external Time Clock. See Page 21.

SYSTEM STATUS

High Level Alarm

- Upon a High Level Alarm, the indicator will come on and the relay contacts will close.
- A High Level Alarm is delayed for ten seconds after power is applied.
- The High Level Alarm relay contacts will be closed when there is no power on the controller.
- The moment electrical power is applied to the controller, the High Level Alarm relay contacts open.
- The High Level Alarm relay contacts will close if there is a complete failure of the controller.
- The High Level Alarm will be activated as the level rises to or above the High Level Alarm level setting.
- A High Level float will activate the alarm. The Discrete Input used must be assigned Function 12 or 29.
- A High Level from a Level Probe input will activate the alarm. See Parameter b.06.
- With the Level Input Source set for the Level Probe (Parameter F.19 = 2 or 3), if not already on, the High Level Alarm will be activated when Electrode 1 is covered with liquid.

Low Level Alarm

- Upon a Low Level Alarm, the indicator will come on and the relay contacts will close.
- A Low Level Alarm is delayed for 90 seconds after power is applied.
- The Low Level Alarm relay contacts will be open when there is no power on the controller.
- The Low Level Alarm will be activated when the level is at or below the Low Level Alarm level setting.
- A Low Level float will activate the alarm. The Discrete Input used must be assigned Function 11 or 24.
- A Low Level from a Level Probe input will activate the alarm. See Parameter b.01.
- The Low Level Alarm will not function as a redundant pump off, except for the Low Level Alarm from Float Backup using a Discrete Input programmed for Function 24, which will turn off the pumps.
- With the Level Input Source set for the Level Probe (Parameter F.19 = 2 or 3), if not already on, the Low Level Alarm will be activated when Electrode 10 is uncovered, unless it is disabled using Parameter P.50.
- Low Level Alarm operation may be disabled by setting Parameter P.50 = 0. This disables Low Level Alarm operation from either the Analog Level Input (Parameter F.19 = 1) or from a Level Probe (Parameter F.19 = 2 or 3). However, it will not disable alarm operation from a Low Level float input using a Discrete Input (Function 11 or 24), or from the Backup Low Level Probe input (See Parameter b.01).

Fault Indication

The Fault indicator shows when there is something wrong with the system, and that there is a non-zero Fault Code present in Parameter FLC. Please see the Fault Code Table on pages 18 - 19.

Fault Code - Parameter FLC

The current Fault Code may be viewed at Parameter FLC. Fault Codes 20 - 29 latch into memory but are reset when the power is cycled, or may be reset by pressing the down push-button while viewing the Fault Code. The Fault Code may also be reset remotely by setting Coil 31 in SCADA Register 40002.

Last Fault Code - Parameter LFC

The Last Fault Code (Parameter LFC) is a copy of the last non-zero Fault Code that was present in Parameter FLC. Parameter LFC is reset when power is cycled, or may be reset by pressing the down push-button while viewing the Last Fault Code. The Last Fault Code may also be reset remotely by setting Coil 31 in SCADA Register 40002.

FAULT CODE TABLE

Fault Code	Description of Condition
0	Normal
1	Communication Fault - Overrun Error reading incoming message.
2	Communication Fault - Time out error reading incoming message.
3	Communication Fault - Time out error responding to message.
4	Communication Fault - Incoming message failed Checksum Test.
5	Communication Fault - Invalid Modbus Function Code.
6	Communication Fault - Trying to preset more than 35 registers using Function Code No. 16.
7	Communication Fault - Trying to force to more than 100 Coils using Function Code No. 15.
8	Parameter Setup Fault - More than one Discrete Input is assigned to the same Function.
9	Parameter Setup Fault - Pump On & Pump Off parameters are set too close together. (They must be at least 0.2 feet apart with P.36 = 1, or 2 feet apart with P.36 = 0, or 0.02 feet apart with P.36 = 2.)
10	Parameter Setup Fault - Pump On & Pump Off parameters are upside down. (Pump Off Level must be lower than the Pump On Level, for a pump down application.)
13	Communication Fault - The UART detected a Framing Error reading the incoming message. It did not find Stop Bit where expected.
14	Communication Fault - Noise Detected on incoming message.
15	Normal Pump Operation Disabled - Discrete Input programmed for Function 23 is closed. Pump Operation will only be allowed from Float Backup or Level Probe Backup.
16	Pump Operation on Float Backup.
17	Backup Float Switch Out of Sequence. Note: Fault will clear when normal operation is verified.
18	All Pump Disable - Discrete Input programmed for Function 7 is closed (Typically connected to Phase Monitor).
19	One of the Pump On or Pump Off level control Parameters (or Parameters P.42, or P43) is set too low. One of them is set in the part of the display range that is artificially created by the Level Offset Parameter F.21. See page 5 for a description of Parameter F.21. All level control Parameters must be set higher than what is set on Parameter F.21.
20	Level Probe Fault - Test Signal Status Below Normal Range. See notes on Parameter L.11 on page 7.
Fault Codes 21 - 29 Level Probe Fault Electrodes Covered Out of Sequence	
21	Electrode 1 Covered before Electrode 2
22	Electrode 2 Covered before Electrode 3
23	Electrode 3 Covered before Electrode 4
24	Electrode 4 Covered before Electrode 5
25	Electrode 5 Covered before Electrode 6
26	Electrode 6 Covered before Electrode 7
27	Electrode 7 Covered before Electrode 8
28	Electrode 8 Covered before Electrode 9
29	Electrode 9 Covered before Electrode 10
30	Pump(s) are Called to Operate by the Level Probe Backup Pump Control.

Notes:

1. Level Probe Fault Codes 20-29 must be present for at least 60 seconds for the fault to be latched into memory.
2. To reset the fault, scroll to and view Parameter FLC. Record the Fault Code, then press the Down push-button while viewing the Fault Code. Cycling power to the controller will also reset the Fault Code.
3. The analog value associated with each of the Level Probe Electrodes may be viewed from Parameters L.01 - L.10. See Page 7.

FAULT CODE TABLE

Fault Code	Description of Condition
31	Communication Fault - Write Attempt to Register Not Marked for "Write" using Function Code No. 05.
32	Communication Fault - Write Attempt to Register Not Marked for "Write" using Function Code No. 06.
33	Communication Fault - Write Attempt to Register Not Marked for "Write" using Function Code No. 15.
34	Communication Fault - Write Attempt to Register Not Marked for "Write" using Function Code No. 16.
35	Communication Fault - Write Attempt made with Register Access Mode Parameter set for Read Only.
36	Flow Calculator Setup Fault - Average Daily Inflow Total is too Large to Display. Set Parameter P.45 = 2.
37	Communication Lost - While Setup for Remote Level Input from SCADA (Parameter F.19 = 4).

ANALOG LEVEL INPUT (4-20mA Input) – CALIBRATION PROCEDURE

The following calibration is for the 4-20mA Analog Level Input (Parameter F.19 = 1) and does not apply when a 10 Electrode Level Probe is used (Parameter F.19 = 2 or 3).

Parameters P.24 and P.25 show the Wet Well Level, while allowing the Up & Down push-buttons to be used to change the internal numbers involved in calculating the displayed level. Therefore, the appropriate 4-20mA signal must be applied to the Level Input during each step of the calibration procedure.

If Parameters P.24 and P.25 show 77.7 feet in the display, then Parameter F.19 is setup to follow the Level Probe input. To calibrate the level display when using the Level Probe, the distance between the electrodes must be set on Parameter F.20, and Parameters P.24 and P.25 are not used.

The 4-20mA Analog Level Input signal conditioning may be slowed down or speeded up using Parameter P.49.

LEVEL INPUT ZERO - Parameter P.25

This parameter is used to make the display read zero feet of water with a Wet Well Level input of 4.0mA.

Calibration Procedure:

1. Apply a 4.0mA signal to the Wet Well Level Analog Input.
(Alternate Procedure - Pull the pressure transducer or bubbler tube out of the water.)
2. Scroll to the place in the System Setup Sub-Menu where Parameter P.25 is displayed.
3. Press the Scroll / Change mode push-button. (The Wet Well Level will be displayed.)
4. Use the Up / Down push-buttons to make the display read zero feet. Note: It is slow to change at first.
5. Perform the procedure below to calibrate the "LEVEL INPUT SPAN" Parameter.

LEVEL INPUT SPAN - Parameter P.24

This parameter is used to establish the Wet Well Level (in feet) that corresponds to an analog input of 20mA.

Calibration Procedure:

1. Apply a 20mA signal to the Wet Well Level Analog Input.
(Alternate Procedure – Subject the pressure transducer or bubbler tube to a known depth of water.)
2. Scroll to the place in the System Setup Sub-Menu where Parameter P.24 is displayed.
3. Press the Scroll / Change mode push-button. (The Wet Well Level will be displayed.)
4. Use the Up / Down push-buttons to make the display read the level (in feet of water) that your 20mA signal represents. Note: It is slow to change at first.

(Alternate Procedure – Use the Up / Down push-buttons to make the display read the number of feet of water that the pressure transducer or the end of the bubbler tube is submerged under.)
5. Repeat the procedure above for the "LEVEL INPUT ZERO" Parameter.

LEVEL DISPLAY SPAN VERSUS TRANSDUCER CALIBRATION

		Transducer Calibration						
		4.33psi @ 20mA	5.0psi @ 20mA	10psi @ 20mA	15psi @ 20mA	30psi @ 20mA	60psi @ 20mA	
Level Display Span	-	-	-	-	-	139 feet	231 feet	P.36 = 0
	-	11.5 feet	23.1 feet	34.6 feet	69.3 feet	-	-	P.36 = 1
	9.99 feet	-	-	-	-	-	-	P.36 = 2

Notes:

1. Level Display Span is what is displayed with a 20mA Level Input.
2. Parameter P.36 is used to set the decimal point position.
3. To find the Level Input Span Setting for other transducers use the following equation:

$$\text{Pressure (psi)} \times 2.309 = \text{Level (feet of water)}$$

FLUSH CYCLE

The Flush Cycle feature is provided to periodically maximize the lift station's discharge flow rate, to flush the sludge build up from the bottom of the wet well and from the discharge pipe.

Flush Cycle Steps:

1. The "LEVEL" indicator begins to flash to indicate that the Flush Cycle has started.
2. Normal pump operation is suspended. Any pumps currently running are turned off.
3. Waits for the level to rise to the "Flush Cycle Start Level" set on Parameter P.43.
4. Turns on all available pumps with the Lag Pump Delay between each additional pump call.
5. Pumps the level down to the "Flush Cycle Stop Level" set on Parameter P.42.
6. Turns off all pumps.
7. The "LEVEL" indicator returns to normal to indicate that the Flush Cycle has ended.

Automatically Starting Flush Cycle:

- A. Internal Time Delay - Expiration of "Delay Between Flush Cycles" set on Parameter P.41.
- B. External Time Clock - Closure of a Discrete Input that is programmed to perform Function 30.
- C. Programming the SCADA system to momentarily set Coil 139 in SCADA Register 40009.

Manually Starting / Stopping Flush Cycle:

Start - Press and hold the LEVEL Push-Button until the "LEVEL" indicator begins to flash.
(Momentarily set Coil 139 in SCADA Register 40009.)

Stop - Press and hold the LEVEL Push-Button until the "LEVEL" indicator returns to normal.
(Momentarily set Coil 140 in SCADA Register 40009.)
(Ends Flush Cycle even if it was started by the Time Delay or External Time Clock.)

Notes:

1. The Flush Cycle Feature only works in the "Pump Down" mode, (P.19 = 1). If Parameter P.19 is changed to "Pump Up" mode (P.19 = 2), then Parameter P.40 will be set to "0".
2. Use of an External Time Clock to start the Flush Cycle may be preferred, because it would provide control over when the Flush Cycle occurs.
3. The number of pumps called to run by the Flush Cycle logic is always limited by the following:
 - A. Parameter P.14 - Number of Pumps Allowed to Run At the Same Time.
 - B. Closed Discrete Inputs that are Programmed for Pump 1 (2, 3) Disable, or All Pump Disable.
4. All backup systems must be setup so that they do not activate within the Flush Cycle operating range set on Parameters P.42 and P.43.
5. The Low Level Float Backup (Discrete Input programmed for Function 24) will turn off all pumps upon low level. Therefore, the Flush Cycle Stop Level must be set higher than the Low Level Float.
6. The Flush Cycle Status (Active or Inactive) may be read from Coil 141 in SCADA Register 40009.

FLUSH CYCLE - Setup Parameters

Parameter	Default Value	Current Value	Setting Definitions
P.40	0		Flush Cycle Mode 0 = Flush Cycle Disabled 1 = Activated by Internal Time Delay as set on Parameter P.41 2 = Activated by External Time Clock by the Closure of a Discrete Input programmed to perform Function 30. Note: Time Clock Contacts may stay closed indefinitely, but must re-open in order to reset logic for next Flush Cycle.
P.41	24 hours		Delay Between Flush Cycles Range: 1 - 255 hours
P.42	2.5 feet		Flush Cycle Stop Level Range: 0.2 - 99.9 feet
P.43	9.0 feet		Flush Cycle Start Level Range: 0.2 - 99.9 feet

FLOW CALCULATOR

Latest Inflow Rate - The Most Recently Determined Flow Rate into the Lift Station

The Flow Calculator determines the “Latest Inflow Rate” of liquid flowing into the lift station by observing how long it takes for the wet well level to rise a “known distance”, while all pumps are off. Knowing the surface area of the wet well (Parameter P.46), the volume of liquid per minute flowing into the wet well is calculated. The “known distance” used in the calculation is a change in level of one foot when a Pressure Transducer is used (F.19 = 1), or the distance between electrodes (Parameter F.20) when using a Level Probe (F.19 = 2 or 3). The “Latest Inflow Rate”, in Gallons Per Minute, may be viewed from Parameters FLH & FLL, and is also available for SCADA at Register 40080.

Average Daily Inflow Total - The Flow Totals from the Last 7 days Averaged Together

The Flow Calculator uses the “Latest Inflow Rate” to keep a running total of how much liquid flows into the lift station during a 24 hour period. This is done for each 24 hour period. The flow totals from the previous 7 days are all kept stored. These flow totals are added together and divided by 7. This value is displayed as either “Gallons Per Day” or “Thousand Gallons Per Day” (See Parameter P.45). The “Average Daily Inflow Total” may be viewed from Parameters FdH & FdL, and is also available for SCADA at Register 40081. The 7 days of flow data are also available for SCADA at Registers 40086 - 40092.

Pump Outflow Rate - The Most Recently Determined Outflow Rate of Each Pump

The Flow Calculator determines and updates the “Pump Outflow Rate” of each pump whenever it completes a pumping cycle by itself. This is done by first calculating the volume of liquid in the wet well between the “1st On Level” and the “1st Off Level”, and adding to it what flows in while the pump is running (“Latest Inflow Rate” multiplied by the “Pump Run Time”). This total volume of liquid is divided by the “Pump Run Time” to arrive at the “Pump Outflow Rate”. The most recent “Pump Outflow Rate” of each pump in Gallons Per Minute, may be viewed from Parameters F1H & F1L, F2H & F2L, F3H & F3L and is also available for SCADA at Register 40082 - 40085.

Notes:

1. The Flow Calculator operates for “Pump Down - Empty a Tank” applications only, (Parameter P.19 = 1).
2. The “Average Daily Flow Total” is not valid until after 7 days of operation with Parameter P.44 = 1.
3. In order to have an accurate flow measurement the Flow Calculator must have recently acquired the “ Latest Inflow Rate”. Since this is only acquired while all pumps are off, the station must periodically pump all the way down, and turn off all pumps. Therefore, Parameter P.47 is provided to set the “Delay Before Forcing On Another Pump(s)”. When this delay expires an additional pump or pumps are called to run, and the wet well is pumped down. After calling the first additional pump, there is a 4 minute delay before another is called.
4. While attempting to update the value of the “Latest Inflow Rate”, if the level rises too fast (faster than 1 foot in 15 seconds, with Parameter F.19 = 1, or faster than one Level Probe Electrode spacing in 15 seconds, with Parameter F.19 = 2 or 3, the logic aborts the measurement, and keeps the previously determined value.

FLOW CALCULATOR - Setup Parameters

Parameter	Default Value	Current Value	Setting Definitions
P.44	0		0 = Flow Calculator Disabled 1 = Flow Calculator Enabled Note: All Registers that store Flow Data will be Reset to Zero if P.44 is set on 0.
P.45	2		<u>Average Daily Inflow Total</u> - Display Range 1 = 0 - 65,535 Gallons per Day 2 = 0 - 65,535 Thousand Gallons per Day Note: Parameter P.45 also sets the Display Range of the Daily Inflow Total (Day 1 - 7) read by SCADA at Registers 40086 - 40092.
P.46	79 Square Feet		Surface Area of Wet Well Range: 3 - 999 Square Feet
P.47	30 Minutes		Delay Before Forcing On Another Pump(s) Range: 10 - 60 Minutes

FLOW CALCULATOR - Surface Area Calculation

Gallons = 7.48052 x Cubic Feet

Rectangular Wet Well

$$\text{Area} = \text{Length} \times \text{Width}$$

Where Length & Width Measurements are in: Feet

Circular Wet Well

$$\text{Area} = \pi \left[\frac{1}{2} \text{Diameter} \right]^2 \quad \pi = 3.14159$$

Where Diameter is in: Feet

FLOW CALCULATOR - Display Parameters

Display Range: 0 - 65,535

Latest Inflow Rate

FLH , **FLL**

Thousand Gallons , Gallons Per Minute

SCADA Register: 40080

With: **P.45 = 1**

Average Daily Inflow Total

FdH , **FdL**

Thousand Gallons , Gallons Per Day

With: **P.45 = 2**

FdH , **FdL**

Million Gallons , Thousand Gallons Per Day

SCADA Register: 40081

Note: If Fault Code 36 Appears, Average Daily Inflow Total is too Large to Display. Set Parameter P.45 = 2

Pump 1 Outflow Rate

F1H , **F1L**

Thousand Gallons , Gallons Per Minute

SCADA Register: 40082

Pump 2 Outflow Rate

F2H , **F2L**

Thousand Gallons , Gallons Per Minute

SCADA Register: 40083

Pump 3 Outflow Rate

F3H , **F3L**

Thousand Gallons , Gallons Per Minute

SCADA Register: 40084

Daily Inflow Total (Day 1 - 7)

SCADA Registers: 40086 - 40092

COMMUNICATION WITH A SCADA SYSTEM

A SCADA system may communicate with the controller through either the RS232 Serial Port or through the Optional Ethernet Port. The controller operates as a MODBUS slave, where all communication is initiated by the MODBUS master.

MODBUS Functions Supported

Function Code	Function Description	Notes
01	Read Coil Status	
02	Read Input Status	
03	Read Holding Registers	
04	Read Input Registers	
05	Force Single Coil	
06	Preset Single Register	
08	Diagnostics - Sub-function 00 (Return Query Data)	
15	Force Multiple Coils	Limited to 100 Coils
16	Preset Multiple Registers	Limited to 35 Registers

Setup for Connection to a SCADA System

Parameter	Default Value	Current Value	Setting Definitions
P.28	1		Slave Address (See note 1 below.) Range: 0 - 247
P.33	1		Register Access Mode (See note 2 below.) 1 = Read & Write 2 = Read Only

Notes:

1. Each controller in a SCADA system using the Modbus protocol, is assigned a unique Slave Address so that it can be polled by the SCADA system Master using that unique Slave Address. However, if communication is through the optional Ethernet Port, each controller will already have a unique IP Address. When the Slave Address Parameter P.28 is set on zero, the controller will not reject messages based on the Slave Address, and it will copy the incoming Slave Address for use in the Response.
2. The Register Access Mode Parameter (P.33) is provided to prevent (when set on Read Only) malicious attempts to remotely control the pumps, or change setup parameter values. Unless greatly needed, the Register Access Mode should be left on Read & Write.

RS232 SERIAL PORT

The RS232 serial port allows a SCADA system to communicate with the Controller using the Modbus RTU protocol.

Setup of RS232 Serial Port

The controller's RS232 serial port must be setup to communicate with the device it is connected to. The Baud Rate, Parity Mode and Stop Bits Parameter values of the two devices must be set to match.

The Delay Before Response Parameter (P.32) is provided for cases where the modem needs additional time to prepare itself before receiving a response back from the controller.

Parameter	Default Value	Current Value	Setting Definitions
P.29	4		Baud Rate 1 = 1200 bps 2 = 2400 bps 3 = 4800 bps 4 = 9600 bps
P.30	0		Parity Mode 0 = No Parity 1 = Odd Parity 2 = Even Parity
P.31	2		Stop Bits 1 = 1 Stop Bit 2 = 2 Stop Bits (The 2 nd Stop Bit is available only when No Parity is selected)
P.32	1 ms		Delay Before Response Range: 1 – 100 ms

Serial Port

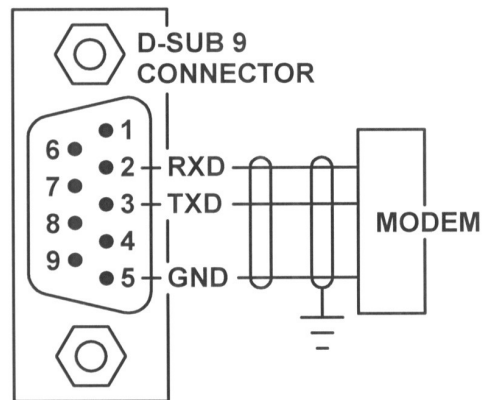

ETHERNET PORT - Option

Features

The Ethernet Port has the following features:

- Protocols Supported: Modbus TCP or Modbus RTU
- IEEE 802.3 Compliant
- 100 Mbps communication speed
- Full-Duplex operation
- Link, and Active status LED indicators

LED Indicator	OFF	ON
LINK (Green)	Not Linked	Linked
ACTIVE (Yellow)	Idle	Active Communication

RJ45 Connector

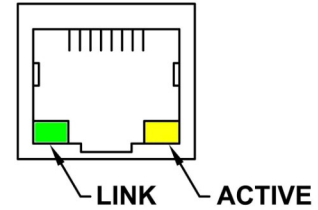

Setup of Ethernet Port

Parameter	Default Value	Current Value	Parameter Definitions
E.01	2		Protocol 1 = Modbus RTU 2 = Modbus TCP
E.14 - E.11	192 . 168 . 80 . 12 (E.14 . E.13 . E.12 . E.11)		IP Address Range: 0 - 255 Identifier for the device on an IP network.
E.44 - E.41	255 . 255 . 255 . 0 (E.44 . E.43 . E.42 . E.41)		Subnet Mask Range: 0 - 255 Range of IP addresses that can be Directly connected in the network.
E.54 - E.51	192 . 168 . 80 . 1 (E.54 . E.53 . E.52 . E.51)		Default Gateway Range: 0 - 255 A node on the network that serves as an entrance to another network when no direct connection exists.
E.62 - E.61	0 , 502 (E.62 , E.61)		Port Number Range: 1 - 65,535

Note:

The Ethernet Port reads the setup values upon power up; any changes require the power to be cycled before the new values are used.

Parameter	Fixed Value	Parameter Definition
E.36 - E.31	0 : 80 : 194 : 219 : XXX : XXX (E.36 : E.35 : E.34 : E.33 : E.32 : E.31)	MAC Address Unique number that identifies each field device. It is set at the factory, and can not be changed.

SCADA REGISTERS

Register Address	Read	Write	Description of Register Contents (Where a Coil is represented by a Bit in a Register)															
40001	✓		Coil															
			16	15	14	13	12	11	10	9	8	7	6	5	4	3	2	1
			Bit															
40002	✓	✓	Coil															
			32	31	30	29	28	27	26	25	24	23	22	21	20	19	18	17
			Bit															
40003	✓		Pump 1 Elapsed Time Meter (hours and 1/10 hours) Range: 0.0 - 6553.5 hours															
40004	✓		Pump 2 Elapsed Time Meter (hours and 1/10 hours) Range: 0.0 - 6553.5 hours															
40005	✓		Pump 3 Elapsed Time Meter (hours and 1/10 hours) Range: 0.0 - 6553.5 hours															
40008	✓		Coil															
			128	127	126	125	124	123	122	121	120	119	118	117	116	115	114	113
			Bit															
40009	✓	✓	Coil															
			144	143	142	141	140	139	138	137	136	135	134	133	132	131	130	129
			Bit															

40010	√	√	160	159	158	157	156	155	154	153	152	151	150	149	148	147	146	145	Coil	
												Pump 3 Remote Control Disable Pump Operation	Pump 2 Remote Control Disable Pump Operation	Pump 1 Remote Control Disable Pump Operation		Pump 3 Called to Run	Pump 2 Called to Run	Pump 1 Called to Run		
			15	14	13	12	11	10	9	8	7	6	5	4	3	2	1	0		Bit
40011	√		Wet Well Level (As shown on display with no decimal point)																	
40012	√	√	Setup Parameter - 1st Pump On Level																	
40013	√	√	Setup Parameter - 1st Pump Off Level																	
40014	√	√	Setup Parameter - 2nd Pump On Level																	
40015	√	√	Setup Parameter - 2nd Pump Off Level																	
40016	√	√	Setup Parameter - 3rd Pump On Level																	
40017	√	√	Setup Parameter - 3rd Pump Off Level																	
40020	√	√	Setup Parameter - High Level Alarm																	
40021	√	√	Setup Parameter - Low Level Alarm																	
40022	√	√	Remote Control - Forced Lead Pump Position (Same as Parameter P.39) 0 = Alternate 1 = Pump 1 Lead 2 = Pump 2 Lead 3 = Pump 3 Lead																	
40023	√		Current Lead Pump Position																	
40025	√	√	Remote Level Input (Must set Parameter F.19 = 4.)																	
40035	√		560	559	558	557	556	555	554	553	552	551	550	549	548	547	546	545	Coil	
												Discrete Input 8	Discrete Input 7	Discrete Input 6	Discrete Input 5	Discrete Input 4	Discrete Input 3	Discrete Input 2		Discrete Input 1
			15	14	13	12	11	10	9	8	7	6	5	4	3	2	1	0		Bit
40036	√		576	575	574	573	572	571	570	569	568	567	566	565	564	563	562	561	Coil	
																Discrete Input 12	Discrete Input 11	Discrete Input 10		
			15	14	13	12	11	10	9	8	7	6	5	4	3	2	1	0		Bit
40037	√		592	591	590	589	588	587	586	585	584	583	582	581	580	579	578	577	Coil	
			Level Probe Electrode 10	Level Probe Electrode 9	Level Probe Electrode 8	Level Probe Electrode 7	Level Probe Electrode 6	Level Probe Electrode 5	Level Probe Electrode 4	Level Probe Electrode 3	Level Probe Electrode 2	Level Probe Electrode 1								
			15	14	13	12	11	10	9	8	7	6	5	4	3	2	1	0		Bit

40047	√		Fault Code (Same as Parameter FLC)
40048	√		Last Fault Code (Same as Parameter LFC)
40049	√		Voltage of +5 Volt Power Supply (Same as Parameter d.01)
40050	√		Voltage of +24 Volt Power Supply (Same as Parameter d.02)
40063	√		Operating Program Revision Number - Controller (Same as Parameter oPr)
40080	√		Flow Calculator - Latest Inflow Rate (Gallons Per Minute) (Same as Param. FLH,FLL)
40081	√		Flow Calculator - Average Daily Inflow Total (Gallons or Thousand Gallons Per Day) (Same as Param. FdH,FdL)
40082	√		Flow Calculator - Pump 1 Outflow Rate (Gallons Per Minute) (Same as Param. F1H,F1L)
40083	√		Flow Calculator - Pump 2 Outflow Rate (Gallons Per Minute) (Same as Param. F2H,F2L)
40084	√		Flow Calculator - Pump 3 Outflow Rate (Gallons Per Minute) (Same as Param. F3H,F3L)
40086	√		Flow Calculator - Daily Inflow Total - Day 1 (Gallons or Thousand Gallons Per Day)
40087	√		Flow Calculator - Daily Inflow Total - Day 2 (Gallons or Thousand Gallons Per Day)
40088	√		Flow Calculator - Daily Inflow Total - Day 3 (Gallons or Thousand Gallons Per Day)
40089	√		Flow Calculator - Daily Inflow Total - Day 4 (Gallons or Thousand Gallons Per Day)
40090	√		Flow Calculator - Daily Inflow Total - Day 5 (Gallons or Thousand Gallons Per Day)
40091	√		Flow Calculator - Daily Inflow Total - Day 6 (Gallons or Thousand Gallons Per Day)
40092	√		Flow Calculator - Daily Inflow Total - Day 7 (Gallons or Thousand Gallons Per Day)

SCADA FEATURES

Level

Level Monitoring

The Level may be monitored by reading SCADA Register 40011. The value will be just what is displayed on the front of the controller but with no decimal point. If an operator has the Controller in the Level Simulation Mode, Register 40011 will show the simulated level.

Remote Level Input

In cases where the pumps empty or fill a remote tank, the SCADA system Master may be programmed to collect the level data from the remote tank and write the level to SCADA Register 40025 in the Controller. For the Controller to follow the value in Register 40025, Parameter F.19 must be set on 4. Also, the value written to Register 40025 must already be scaled into feet as it would be displayed on the front of the Controller, but with no decimal point. The decimal point is artificially inserted by the Controller based on Parameter P.36. For example, a level of 8.6 feet would be written as 86 (assuming that Parameter P.36 = 1).

If SCADA communication is lost, Register 40025 will no longer receive current level data. With the loss of communication the Controller will turn off all pumps and turn on the Fault indicator and place Fault Code 37 in Parameter FLC. The Level Display will also flash and show the last value written to Register 40025. Loss of communication is established when the delay set on Parameter P.38 expires. The time delay setting on Parameter P.38 must be set long enough so that it will not time out during the interval between normal communication events.

Discrete Inputs

The status of all the Discrete Inputs may always be read from Coils 545 - 552 in Register 40035, and Coils 561 - 564 in Register 40036, regardless of what function may be assigned to the inputs.

Discrete Inputs assigned Functions 13 - 22 (Telemetry A - L) place their status in predetermined Coils, but do not perform any other function. The status of these inputs may be read from Coils in Registers 40001, and 40008.

Discrete Inputs assigned with Functions 6 - 7, 11 - 12 and 24 - 29 perform their respective function and place their status in predetermined Coils. The status of these inputs may be read from Coils in Registers 40001, and 40008.

Pump On / Off and Alarm Levels

The Pump On, Pump Off, High Alarm, and Low Alarm levels may be viewed and changed at Registers 40012 - 40021.

Disabling Pump Operation

To Disable a Pump set Coil 149, 150, or 151 in Register 40010. To return a pump to normal operation, clear the respective Coil.

Upon a loss of serial communication, the Pump Disable Logic will be automatically reset, and any pump that had been remotely disabled will be re-enabled after the delay set on Parameter P.38. For this feature to work properly, the master must poll the Controller at intervals shorter than the time set on Parameter P.38. However, if Parameter P.38 is set on 255 the pumps will remain disabled until power is lost.

Forcing a Pump On

To Force a Pump On set Coil 17, 18, or 19 in Register 40002. To return the pump to normal operation, clear the respective Coil.

Upon a loss of serial communication, the Force Pump On Logic will be automatically reset, and any pump that had been remotely forced on will be turned off after the delay set on Parameter P.38. For this feature to work properly, the master must poll the Controller at intervals shorter than the time set on Parameter P.38. However, if Parameter P.38 is set on 255 the pumps will remain on until power is lost.

SCADA FEATURES

Forcing Pump Alternation

To force Pump Alternation, momentarily set Coil 136 in Register 40009. When alternation is to be regularly performed through the SCADA system, automatic alternation should be disabled by setting Parameter P.18 to equal 2.

Forcing Lead Pump Position

The Forcing of the Lead Pump Position may be accomplished by writing a 1,2, or 3 to Register 40022. To return to normal alternation, write a zero to the register. Setting Register 40022 does not guarantee that the pump selected will be lead. If the pump selected as lead is disabled (by a pump disable Discrete Input), then the next available pump will be made lead. A lead pump selector switch connected to Discrete Inputs, programmed as sequence inputs, will also override what is written to Register 40022. The setting may also be changed at Parameter P.39. The content of Register 40022 is saved in non-volatile memory. The current lead pump position may be read from Register 40023.

Remote Control of Relays

Relays that are not needed for pump control or alarm outputs, may be controlled remotely by setting their Output Function (Parameters F.31 - 35) to 2 .

Remote control is accomplished by setting or clearing Coils 25 - 29 in Register 40002.

Upon a loss of serial communication, Coils 25 - 29 will automatically be cleared after the delay set on Parameter P.38. For this feature to work properly, the master must poll the Controller at intervals shorter than the time set on Parameter P.38. However, if Parameter P.38 is set on 255 the relays will remain as commanded, until power is lost.

The HI Relay operates differently from the others. It has a normally closed contact, with the logic inverted. Setting Coil 25 in Register 40002 de-energizes the HI Relay closing the contact. When power is lost to the Controller the HI Relay contact will close.

Flush Cycle

To Start Flush Cycle, momentarily set Coil 139 in Register 40009.

To Stop Flush Cycle, momentarily set Coil 140 in Register 40009.

Flush Cycle Active / Inactive status may be read from Coil 141 in Register 40009.

Flow Calculator Data

Flow Calculator Data may be read from Registers 40080 - 40092. See Pages 22 - 23.

High Level Telemetry

The **High Level Alarm** is generated from a comparison of the displayed Level with the High Level alarm setting. This alarm works when Parameter F.19 is set on either 1, 2 or 3. The status of this alarm may be read from Coil 129 in Register 40009. This alarm will also set Coil 1 in Register 40001.

The **High Float Alarm** is generated by the closure a float switch connected to a discrete input programmed for either function 12 or 29. The status of this alarm may be read from Coil 120 in Register 40008. This alarm will also set Coil 1 in Register 40001.

The **Probe Backup High Level Alarm** is generated when liquid covers the High Level Electrode of a Level Probe Input. Parameter b.06 must be setup with the number of the Level Probe Input used to read the High Level. The status of this alarm may be read from Coil 122 in Register 40008. This alarm will also set Coil 1 in Register 40001.

SCADA FEATURES

Low Level Telemetry

The **Low Level Alarm** is generated from a comparison of the displayed Level with the Low Level alarm setting. This alarm works when Parameter F.19 is set on either 1, 2 or 3. The status of this alarm may be read from Coil 130 in Register 40009. This alarm will also set Coil 2 in Register 40001.

The **Low Float Alarm** is generated by the closure a float switch connected to a discrete input programmed for either function 11 or 24. The status of this alarm may be read from Coil 128 in Register 40008. This alarm will also set Coil 2 in Register 40001.

The **Probe Backup Low Level Alarm** is generated when liquid uncovers the Low Level Electrode of a Level Probe Input. Parameter b.01 must be setup with the number of the Level Probe Input used to read the Low Level. The status of this alarm may be read from Coil 121 in Register 40008. This alarm will also set Coil 2 in Register 40001.

Fault Codes

The Fault Code (Parameter FLC) may be read from Register 40047.

The Last Fault Code (Parameter LFC) may be read from Register 40048.

The Fault Code and the Last Fault Code may be reset by setting Coil 31 in Register 40002.

Elapsed Time Meters

Pump 1-3 Elapsed Time Meters may be read from Registers 40003 - 40005. The values read from these registers are intended for use in comparing the pump run time of one pump with the run time of the other pumps at the station, for the purpose of checking for uneven run times. (Uneven run times is an indication of a maintenance problem with one of the pumps.) Periodically the comparison of run times should be made and the registers should reset to zero. The ETM data is stored in non-volatile memory just prior to a total loss of internal 5V power, so the data is not lost during a power outage. (However, if the serial port is being polled as a power outage occurs, the most recent data may occasionally be lost.) To reset one of the ETMs to zero, momentarily set the respective Coil (21 - 23) in Register 40002.

SCADA TROUBLESHOOTING

Communication Activity Indicator

The Communication Activity Indicator (Parameter d.07) may be used to help troubleshoot communication issues.

It typically pulses from "0" to "1" momentarily to indicate that the master is sending a message. It may stay "1" if there is very little time between messages.

It does not indicate that a valid communication has occurred, only that there is activity on either the RS232 port or the Ethernet port.

When using the Ethernet Port, the Ethernet Board logic will block messages with the wrong IP Address, or when there are setup issues with the Ethernet Port. For the Activity Indicator to be pulsed, the message must be accepted and passed through the Ethernet Board to the Main Controller Board.

Address of Last Slave Polled by Master

The Address of Last Slave Polled by Master (Parameter d.08) may be used to help troubleshoot communication issues.

When using the RS232 port, it shows the address of the last slave that was polled by the master.

When using the Ethernet Port, the Ethernet Board logic will block messages with the wrong IP Address, or when there are setup issues with the Ethernet Port. For Parameter d.08 to show the slave address, the message must be accepted and passed through the Ethernet Board to the Main Controller Board.

Record of Last Modbus Message

If the Slave Address is acceptable and the message does not have an Overrun Error (FLC = 1), Time Out Error (FLC = 2), Framing Error (FLC = 13), or Noise Error (FLC = 14) then the entire Modbus message will be present in data Parameters d.08 - d.86. If the Slave Address is not acceptable or if any of these errors are encountered, the rest of the message is rejected and does not show up in Parameters d.08 - d.86. If the entire message is received (present at Parameters d.08 - d.86), it may fail the Checksum Test (FLC = 4), have an Invalid Modbus Function Code (FLC = 5), or have one of 7 other faults (FLC = 6, 7, or 31 - 35). Failing any of these tests will cause the logic to not perform the Function and not send out a Response.

Communication Fault Codes

Communication Faults will often generate a Fault Code (Parameters FLC and LFC) that may be used to help determine the cause of a communication problem. When this occurs the Fault Indicator will come on.

A valid communication after a Fault will zero Parameter FLC, and will make the Fault Indicator turn off, but the Fault Code will still be available at Parameter LFC. See the Fault Code Table for the description of the communication Fault Codes 1 - 7, 13 - 14, 31 - 35 and 37.

CONNECTION DIAGRAM - STANDARD FEATURES

GENERAL NOTES:

1. ALL DEVICES EXTERNAL TO THE CONTROLLER ARE CUSTOMER SUPPLIED, UNLESS OTHERWISE INDICATED.
2. THE HIGH LEVEL ALARM RELAY CONTACT IS NORMALLY CLOSED WHEN THERE IS NO POWER ON THE CONTROLLER. THE RELAY CONTACT CLOSURES UPON A HIGH LEVEL ALARM CONDITION.
3. USE SHIELDED WIRE FOR ALL DISCRETE INPUT WIRING. GROUND SHIELD AT ONE END.

LEVEL PROBE NOTES:

1. PARAMETER F.19 MUST BE SET ON 2 OR 3 FOR THE CONTROLLER TO FOLLOW THE LEVEL PROBE.
2. PARAMETER F.20 MUST BE SET ON THE DISTANCE BETWEEN THE ELECTRODES (IN INCHES) FOR ACCURATE DISPLAY OF LEVEL.
3. PARAMETER F.22 (LEVEL PROBE SENSITIVITY) MUST BE SET FOR THE TYPE OF LIQUID BEING MEASURED.
4. THE LIQUID IN THE WET WELL MUST BE GROUNDED TO THE CONTROL PANEL GROUND. WHERE A SUBMERSIBLE PUMP IS PRESENT THE GROUNDED HOUSING OF THE PUMP IS SUFFICIENT.

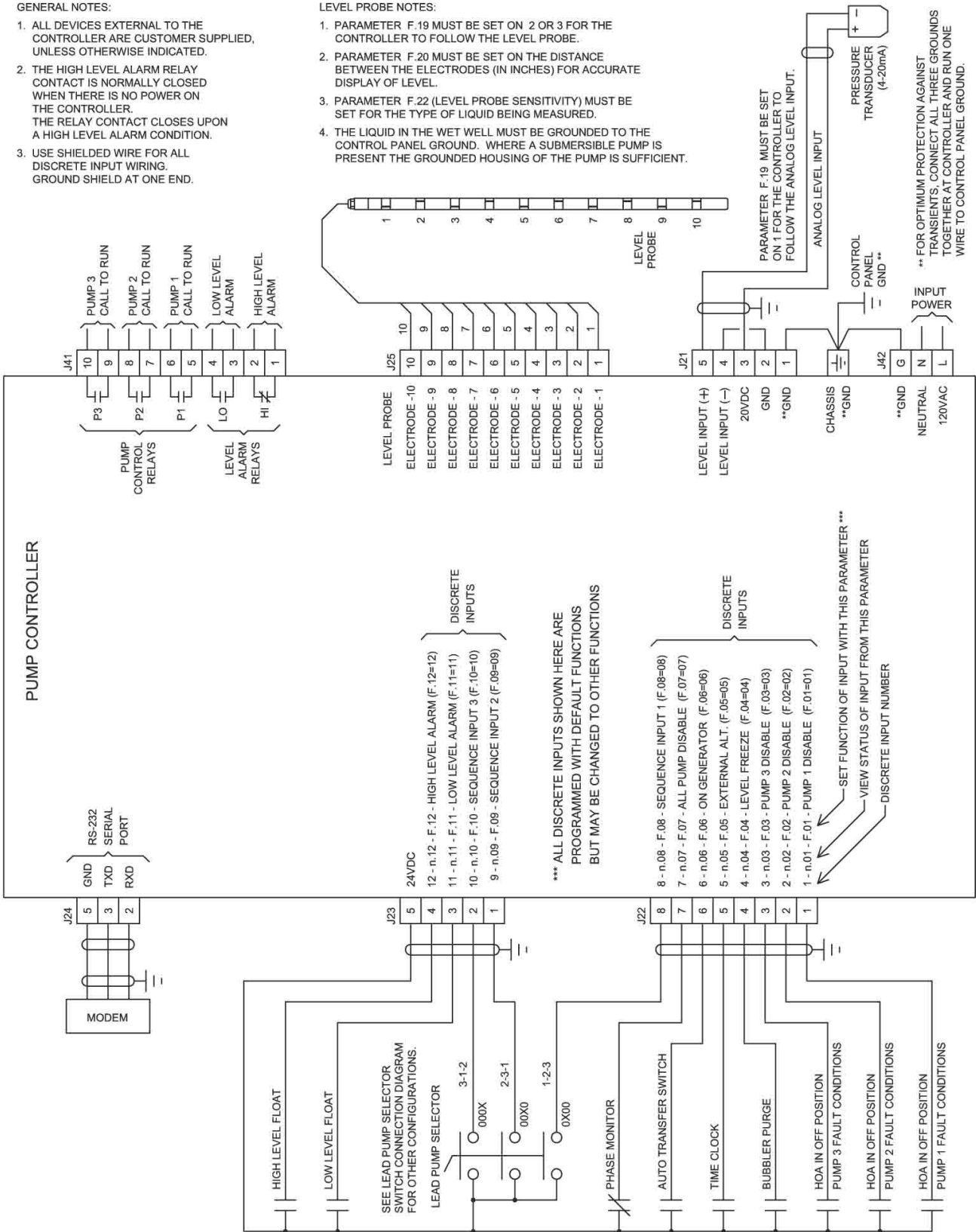

CONNECTION DIAGRAM - LEAD PUMP SELECTOR SWITCH

DUPLEX - STANDARD ALTERNATION

NUMBER OF PUMPS PRESENT: P.13 = 2
 ALTERNATION SEQUENCE MODE: P.16 = 1

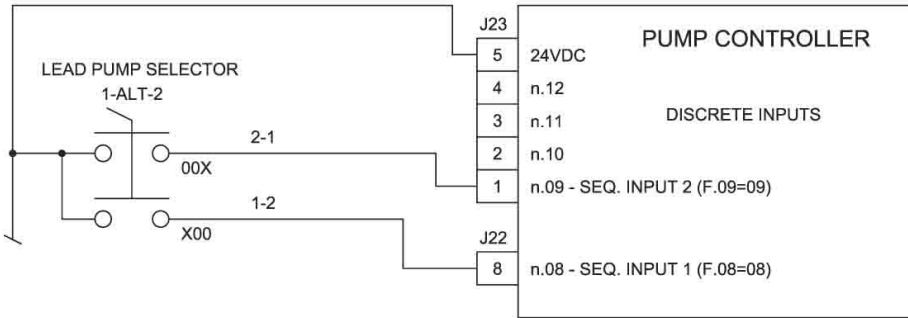

TRIPLEX - STANDARD ALTERNATION

NUMBER OF PUMPS PRESENT: P.13 = 3
 ALTERNATION SEQUENCE MODE: P.16 = 1

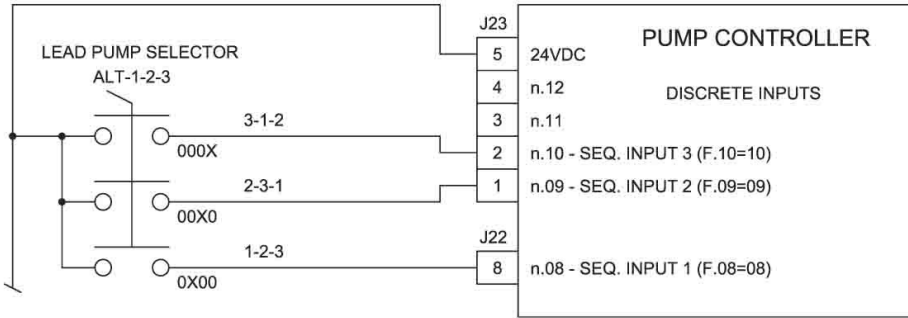

TRIPLEX - PUMP 1 ALWAYS LEAD - PUMPS 2 & 3 ALTERNATE

NUMBER OF PUMPS PRESENT: P.13 = 3
 ALTERNATION SEQUENCE MODE: P.16 = 2 OR 3

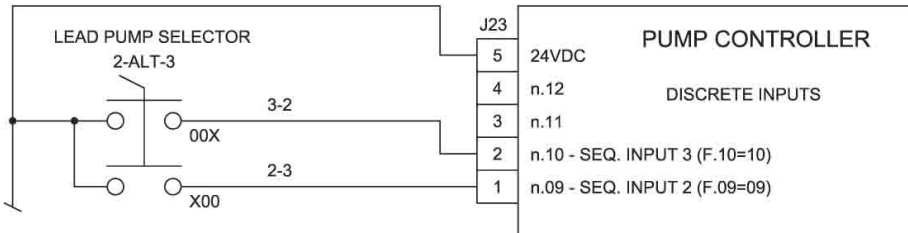

TRIPLEX - PUMPS 1 & 2 ALTERNATE - PUMP 3 ALWAYS LAST

NUMBER OF PUMPS PRESENT: P.13 = 3
 ALTERNATION SEQUENCE MODE: P.16 = 4

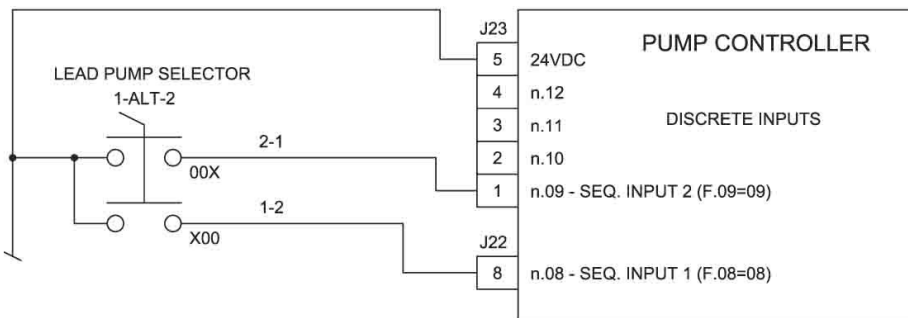

CONNECTION DIAGRAM - ANALOG LEVEL INPUT (4-20mA Input)

SUBMERSIBLE PRESSURE TRANSDUCER CONNECTION

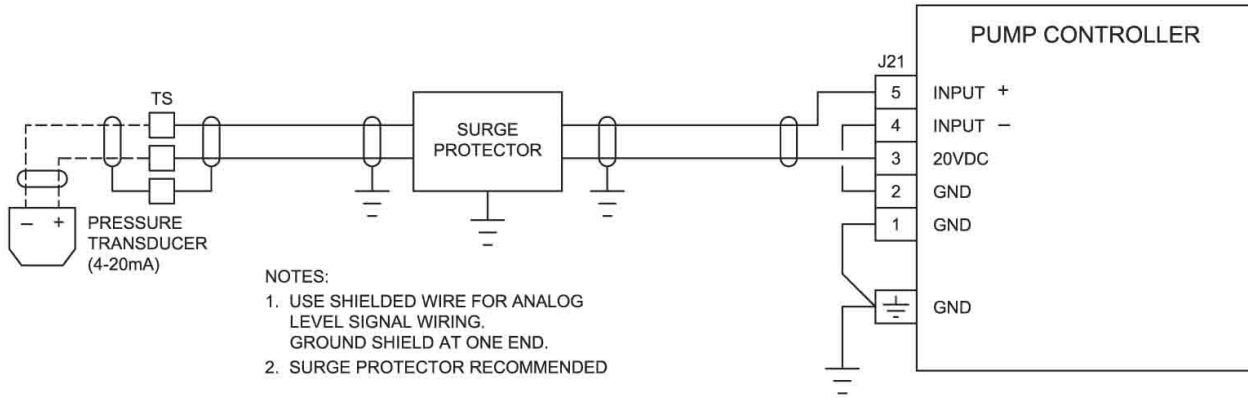

SUBMERSIBLE PRESSURE TRANSDUCER CONNECTION WITH INTRINSICALLY SAFE BARRIER

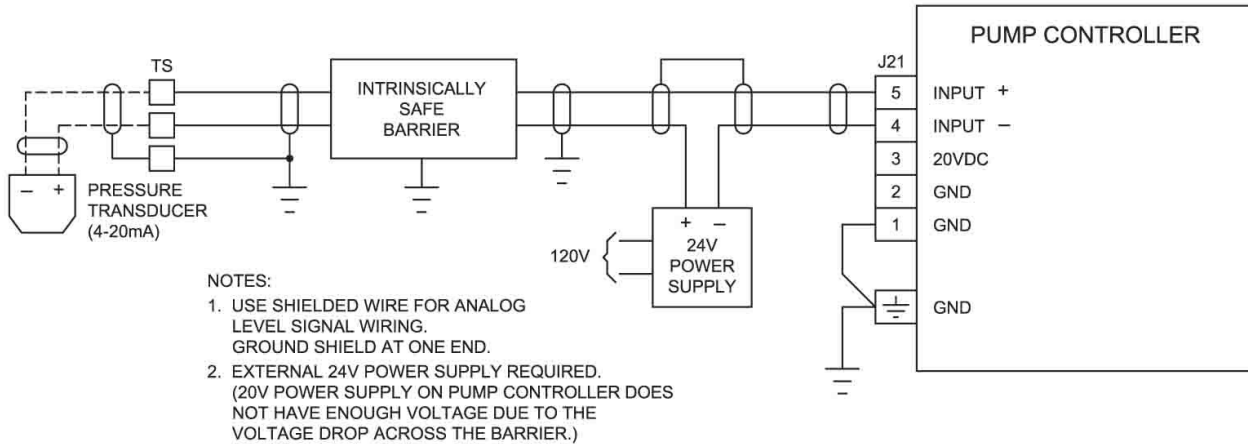

BUBBLER SYSTEM BS2000 CONNECTION

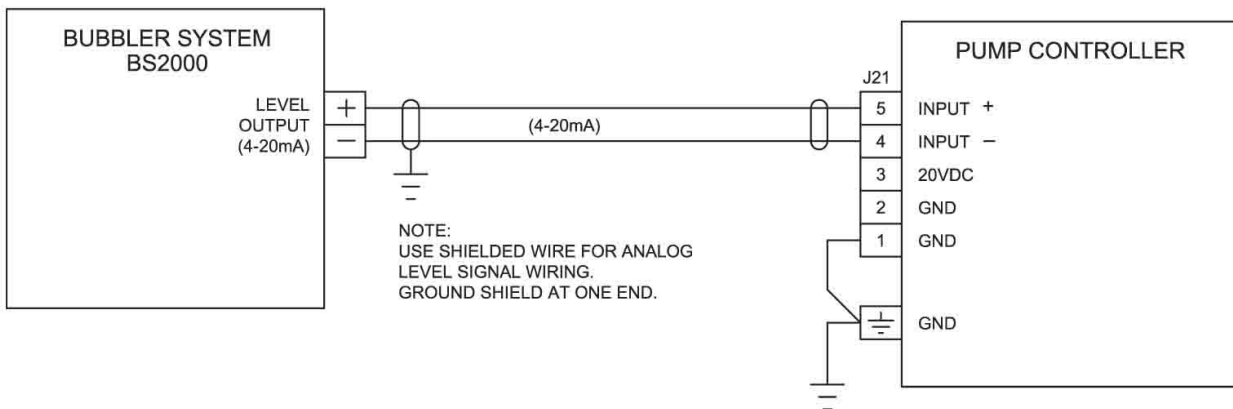

CONNECTION DIAGRAM - LEVEL PROBE

NOTES:

1. INTRINSICALLY SAFE BARRIER IS OPTIONAL.
2. THE LIQUID IN THE WET WELL MUST BE GROUNDED TO THE CONTROL PANEL GROUND. WHERE A SUBMERSIBLE PUMP IS PRESENT THE GROUNDED HOUSING OF THE PUMP IS SUFFICIENT.
3. PARAMETER F.19 MUST BE SET ON 2 OR 3 FOR THE CONTROLLER TO FOLLOW THE LEVEL PROBE.
4. PARAMETER F.20 MUST BE SET ON THE DISTANCE BETWEEN THE ELECTRODES (IN INCHES) FOR ACCURATE DISPLAY OF LEVEL.
5. PARAMETER F.22 (LEVEL PROBE SENSITIVITY) MUST BE SET FOR THE TYPE OF LIQUID BEING MEASURED.
6. PARAMETERS L.01 - L.11 AND FAULT CODES 20 - 29 ARE PROVIDED AS A TROUBLESHOOTING AID.

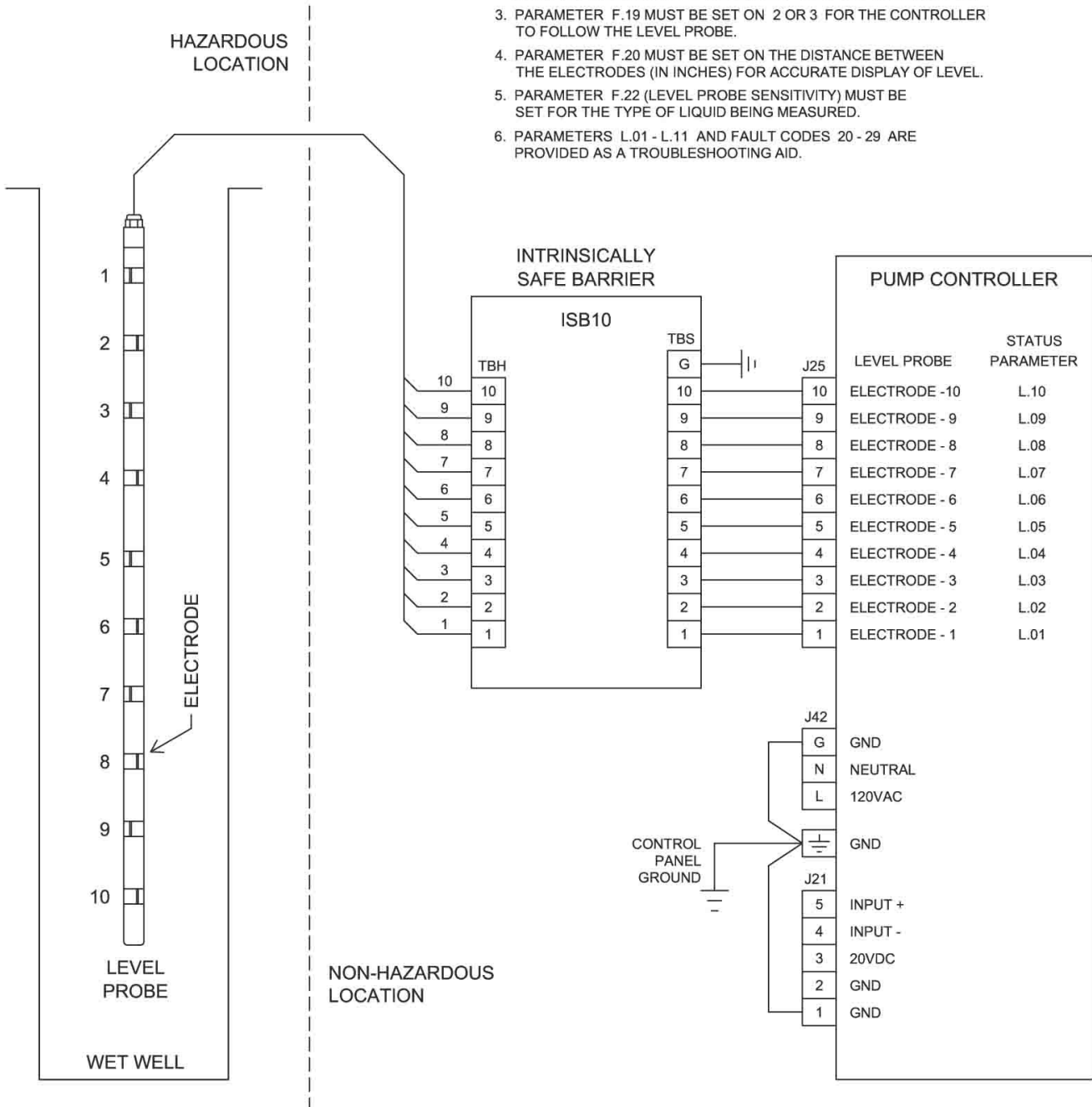

FLOAT BACKUP EXAMPLE - Pump Down

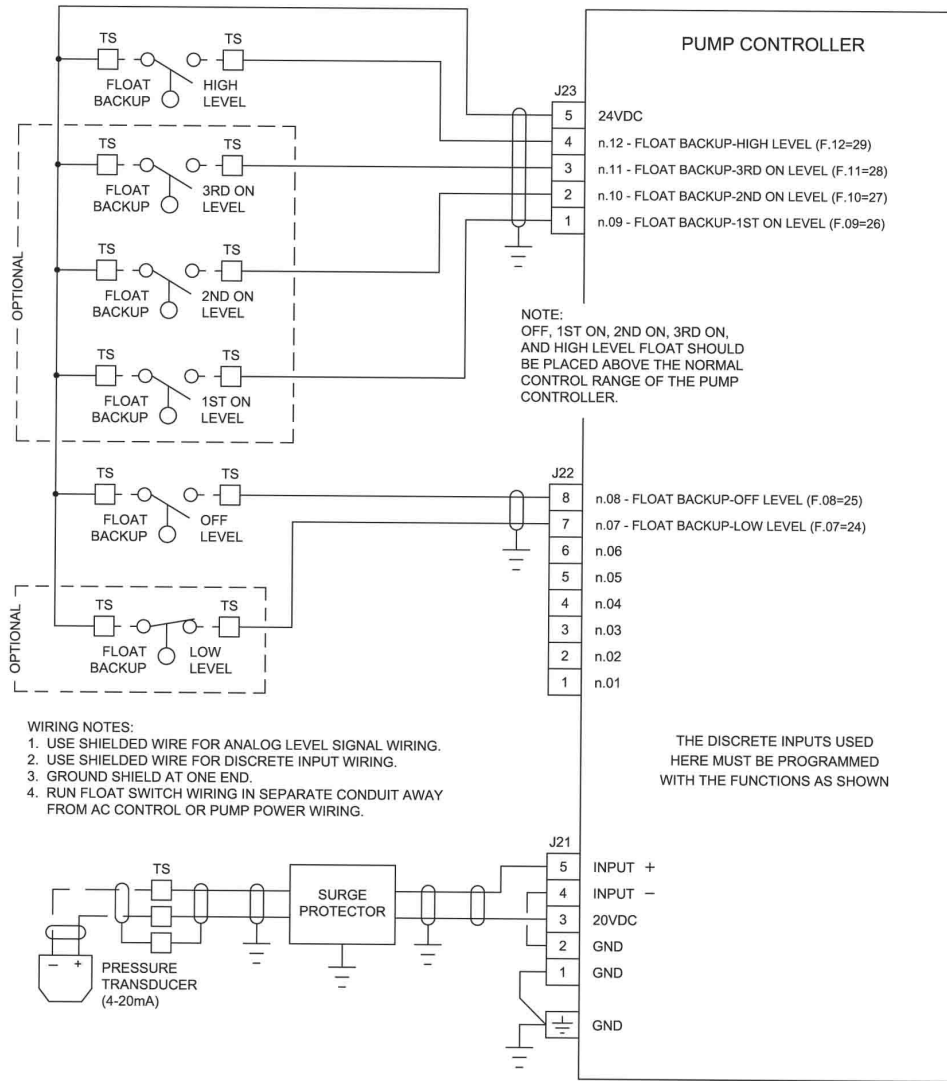

Notes:

1. Pump Down Applications (Parameter P.19 = 1)

Two Float Backup - A simple two float backup system can be made using an Off float and a High float.

High Level Input - Closure of the Float Backup High Level input will cause all pumps to be called to run, provided the Off float input is closed. The Discrete Input used for the High Level must be set on Function 29.

Low Level input - Closure of the Low Level input will disable all pump operation. When the Low Float input opens, a delay prevents the immediate calling of the pumps. This delay is set on Parameter P37. The Discrete Input used for the Low Level must be set on Function 24.

Float Type - For Pump Down applications the Off, 1st, 2nd, and 3rd On, and High floats must be normally open float switches that close as the level rises above the float. The Low Level float must close as the level drops below the float.

2. Pump Up Applications (Parameter P.19 = 2)

Two Float Backup - A simple two float backup system can be made using an Off float and a Low float.

Low Level Input - Closure of the Float Backup Low Level input will cause all pumps to be called to run, provided the Off float input is closed. The Discrete Input used for the Low Level must be set on Function 24.

High Level Input - Closure of the High Level Float Switch will disable all pump operation. When the High Float input opens, a delay prevents the immediate calling of the pumps. This delay is set on Parameter P37. The Discrete Input used for the High Level must be set on Function 29.

Float Type - For Pump Up applications the Low, Off, 1st, 2nd, and 3rd On floats must be normally closed float switches that close as the level drops below the float. The High Level float must close as the level rises above the float.

3. The FAULT light comes on and Fault Code 16 is generated, when a pump is called to run by the Float Backup system.

LEVEL PROBE - PLACEMENT and SETUP

LEVEL PROBE NOTES:

1. PARAMETER F.19 MUST BE SET ON 2 OR 3 FOR THE CONTROLLER TO FOLLOW THE LEVEL PROBE.
2. PARAMETER F.20 MUST BE SET ON THE DISTANCE BETWEEN THE ELECTRODES, IN INCHES, FOR ACCURATE DISPLAY OF LEVEL.
3. PARAMETER F.22 (LEVEL PROBE SENSITIVITY) MUST BE SET FOR THE TYPE OF LIQUID BEING MEASURED.
4. TYPICALLY THE PROBE SHOULD BE PLACED IN THE WET WELL AS SHOWN IN EXAMPLES 2 OR 3.
WHEN REQUIRED THE PROBE MAY BE PLACED AS SHOWN IN EXAMPLE 1. THE PROBE OFFSET MUST BE SET USING PARAMETER F.21. THE PARAMETER VALUE IS ENTERED IN FEET AND TENTHS OF FEET.
5. THE LEVEL PROBE MUST BE CLEANED PERIODICALLY. PROBE MAY BE CLEANED BY PULLING IT THROUGH THE SQUEEGEE FOUND ON THE PROBE MOUNTING BRACKET.

LEVEL PROBE - EXAMPLE 1

PART NO.: LP-79-10-X

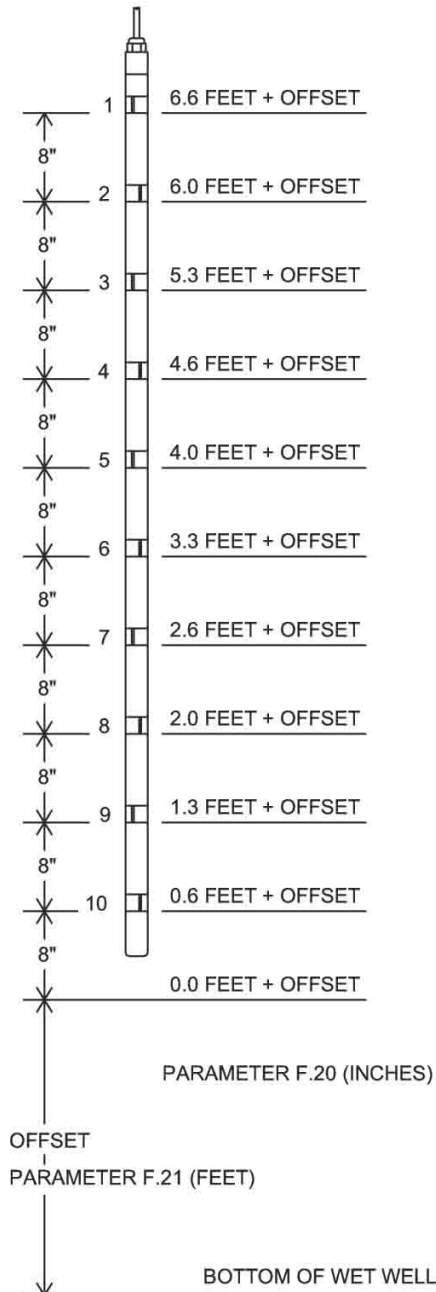

LEVEL PROBE - EXAMPLE 2

PART NO.: LP-97-10-X

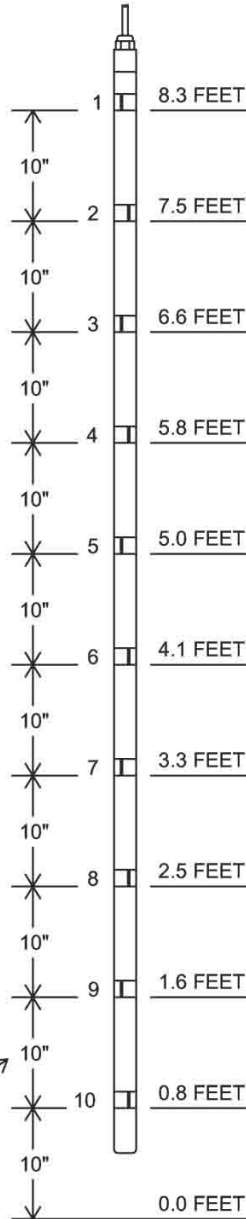

LEVEL PROBE - EXAMPLE 3

PART NO.: LP-115-10-X

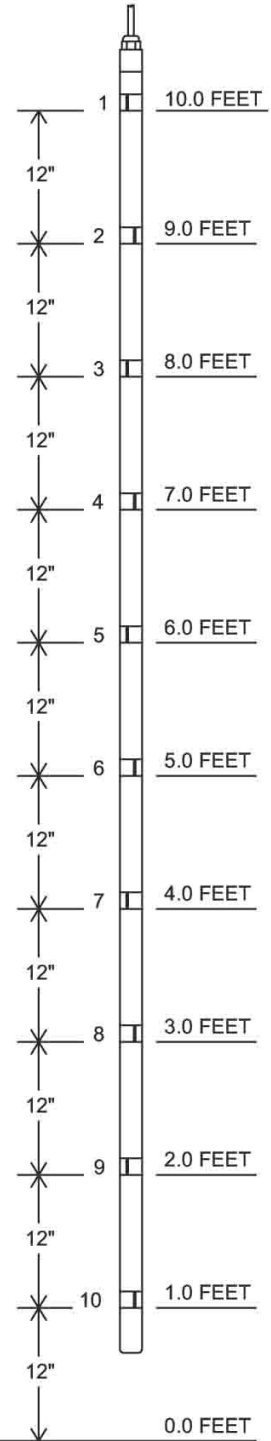

CONTROL SCHEMATIC EXAMPLE - Duplex with 24V Float Backup

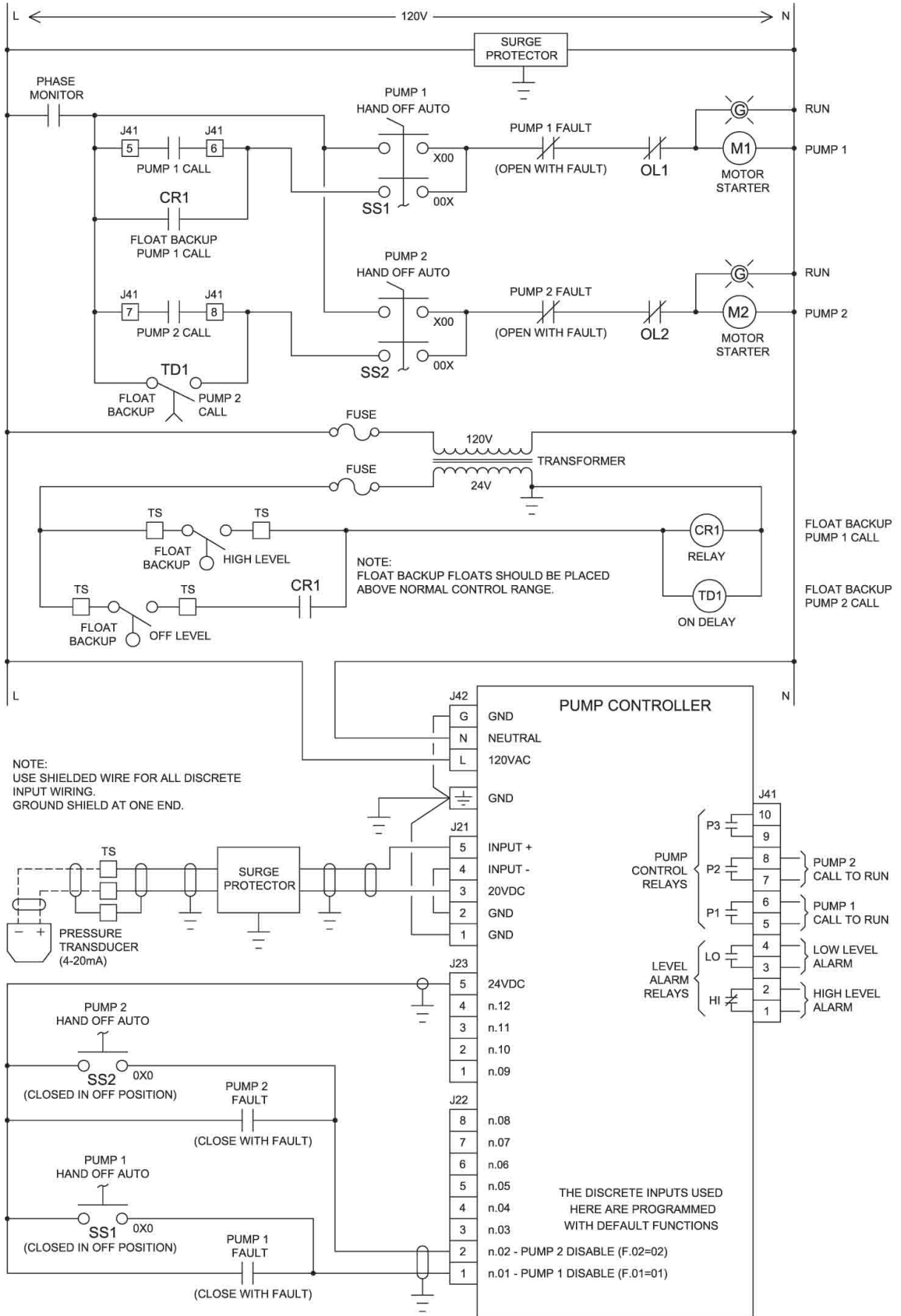

OPERATOR INTERFACE

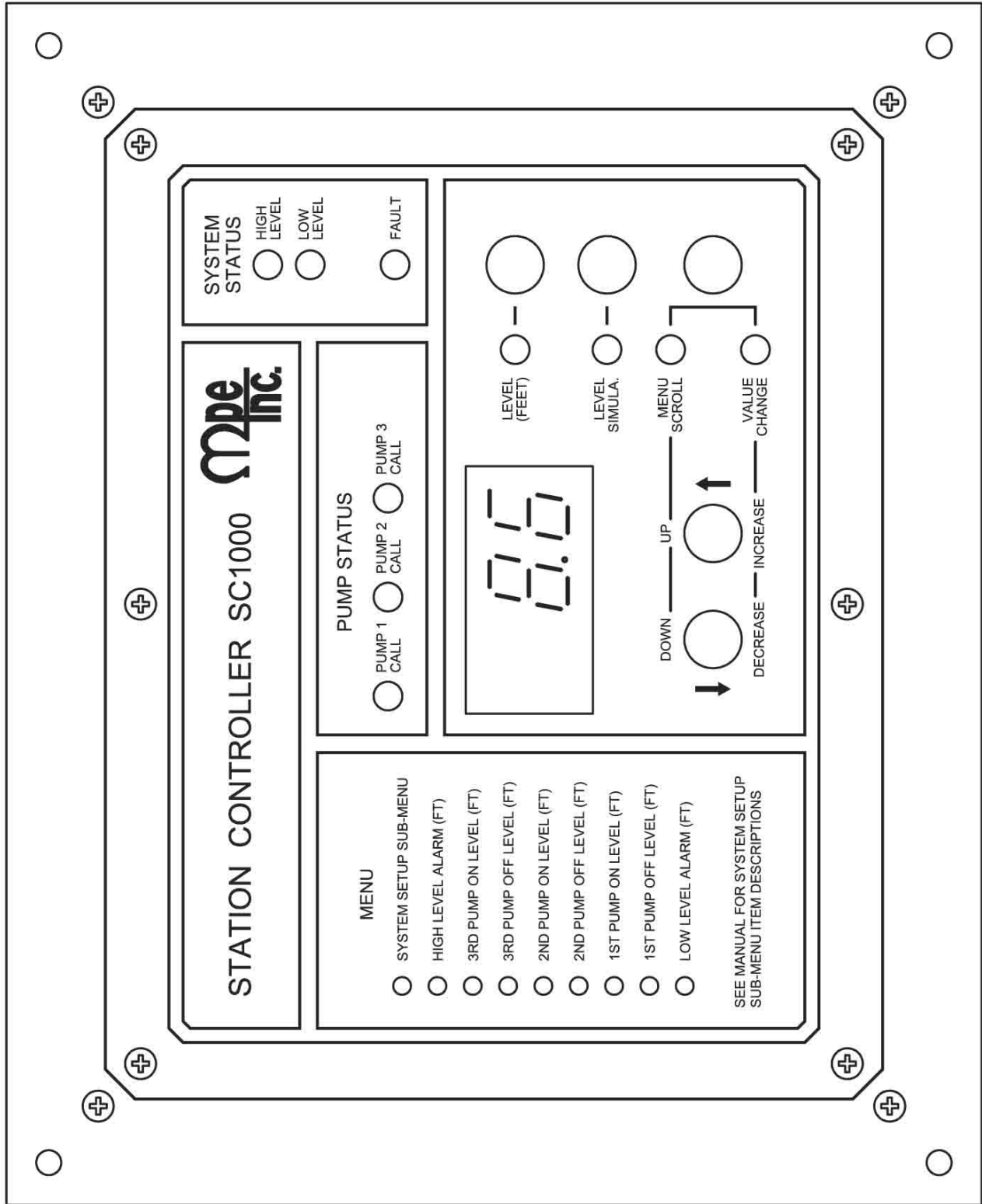

ENCLOSURE MECHANICAL LAYOUT

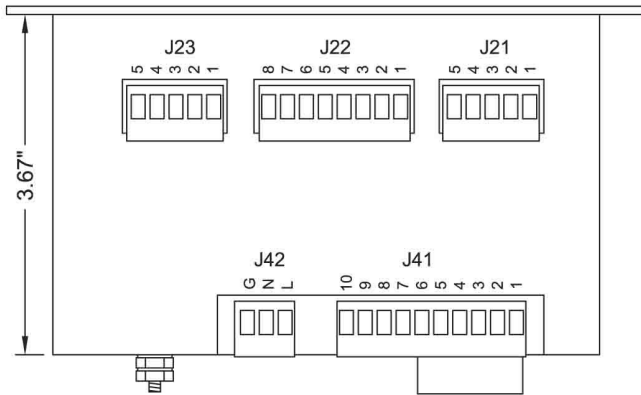

Left Side

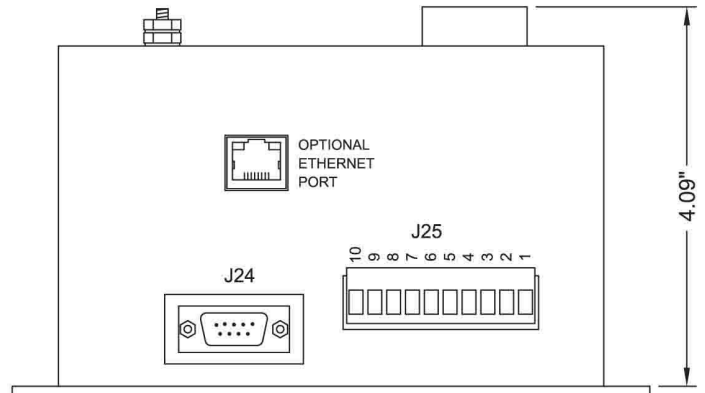

Right Side

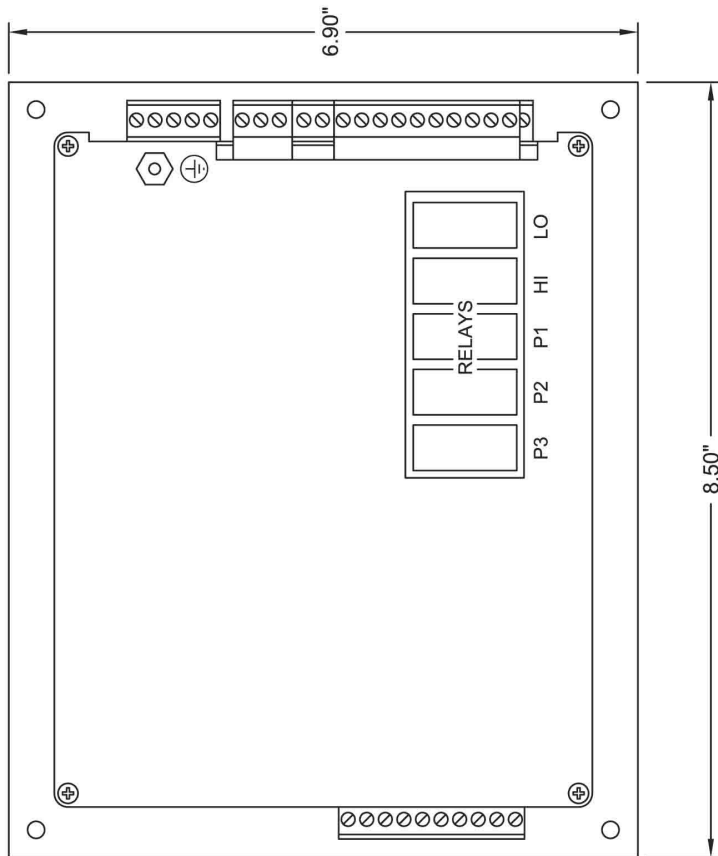

Rear View

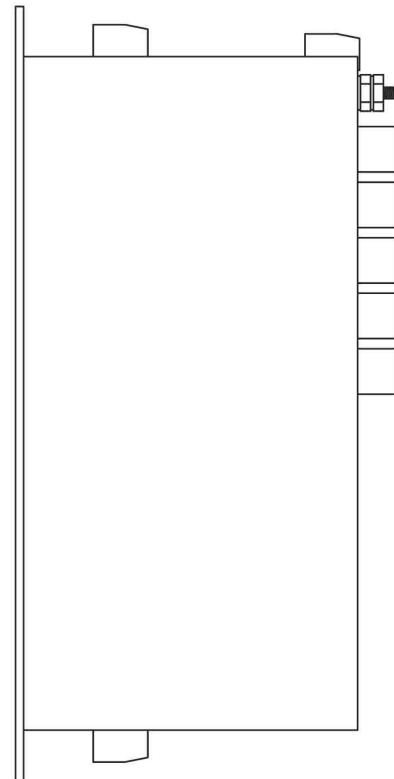

Top View

PANEL CUTOUT

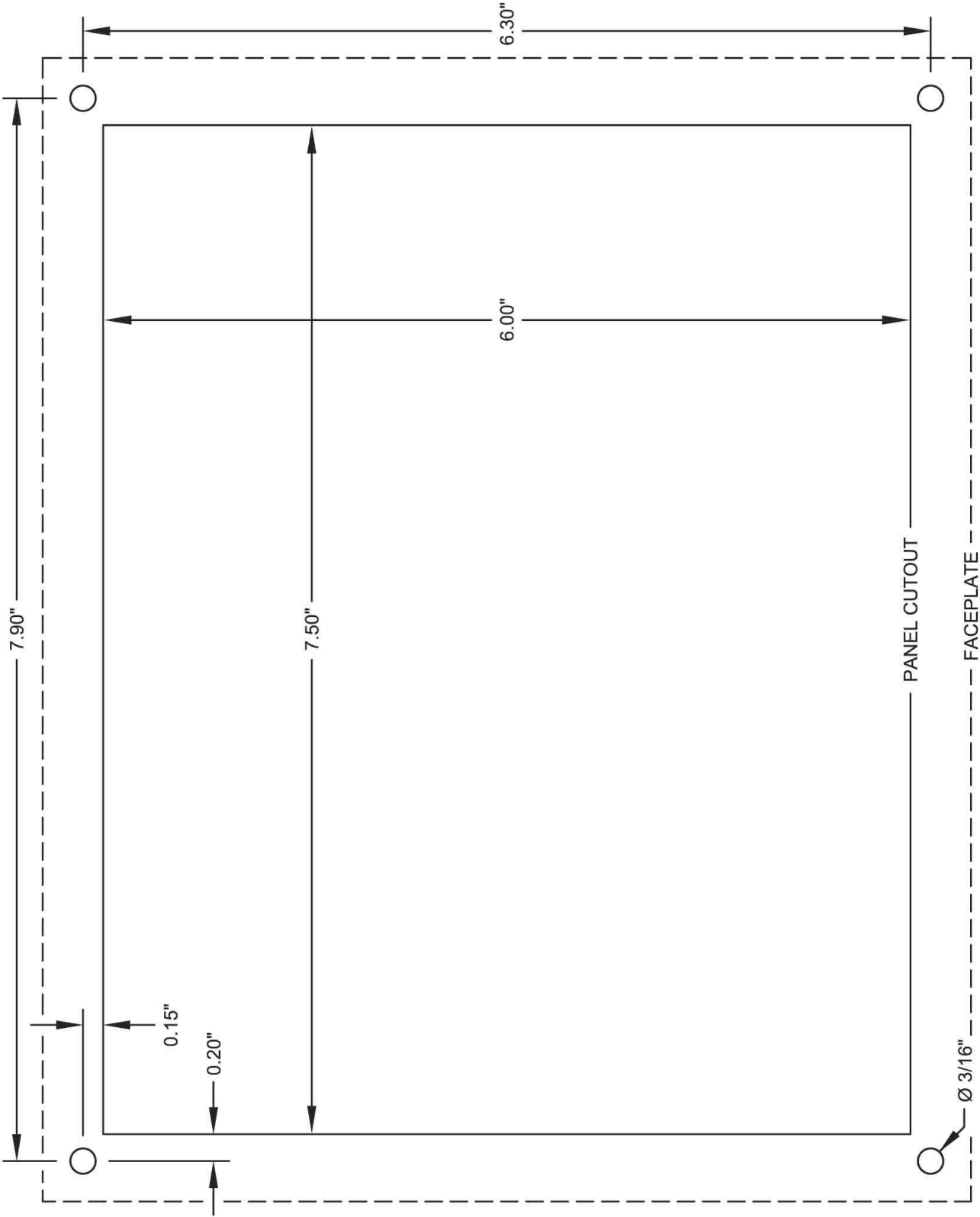

Not Printed to Scale. Do Not Use as a Template.