

SECTION M

ANALOG LEVEL METERS

Revision Date: 12-30-22

ANALOG LEVEL METER - ALM1

Analog Level Meter ALM1 provides all the necessary logic and parameters to take the selected Analog Input's data and process it into a conditioned value scaled into feet and tenths of feet.

The 4-20mA signal from the Level Input device (typically a Pressure Transducer) must be connected to one of the Analog Inputs on the Controller. The Analog Input must be setup so that its data is sent to Analog Level Meter ALM1. To do this, the Analog Input selected for this task must have its Analog Input Setup parameter set for Function 1. See Parameters F.299 - F.308 in Section C. The value of the selected Analog Input in its unscaled form is displayed on Parameter Ld.11.

The logic in the Level Meter takes the value from Parameter Ld.11 and scales it to the Level Input Span (Parameter P.522). The finished value, scaled into feet and tenths of feet, is then made available to be viewed from Parameter Ld.12.

The **Level Input Span** (Parameter P.522) must be set to the calibrated span of the device providing the Level Input. This is the liquid level in feet that corresponds to a 20mA output from the Level Input device.

The **Level Input Zero** (Parameter P.523) is set at the factory so that with a 4.0mA Level Input the Level Meter displays 0.0 feet, with no negative sign. However, since Pressure Transducers and other Level Input devices are often not perfectly zeroed, the HMI provides UP and Down pushbuttons that allow an operator to make minor adjustments in the field to zero the Level Meter display. Before attempting to adjust the Level Input Zero, first pull the Submersible Pressure Transducer out of the liquid, or apply a 4.0mA signal to the Level Input, and then Set the Zero. When properly zeroed the Level Meter display should read 0.0 feet, with no negative sign.

The Signal Conditioning Control parameter (Parameter P.524) determines the speed at which the value displayed on Level Meter ALM1 may change in response to a change in the analog input signal. This is used to filter out sudden changes in the analog level input.

User / Operator Info.		SCADA	Register Address	Description of Parameters and SCADA Notes
Parameter	Default Value	Current Value		
Analog Level Meter ALM1 - Setup Parameters				
P.522	23.10 feet		40522	Analog Level Meter ALM1 - Level Input Span Range: 1.00 - 231.00 feet Note: Parameter P.522 must be set to the calibrated span of the device providing the Level.
P.523	-		40523	Analog Level Meter ALM1 - Level Input Zero Note: The HMI provides UP and Down pushbuttons that allow an operator to make minor adjustments in the field to Parameter P.523 while observing the Level from Parameter Ld.12.
P.524	240		40524	Analog Level Meter ALM1 - Signal Conditioning Control Range: 1 - 254 100 = Slow 240 = Normal 250 = Fast Note: This parameter controls the signal conditioning of Analog Level Meter ALM1
Analog Level Meter ALM1 - Data				
Ld.11	-	-	42139	Analog Level Meter ALM1 - Analog Level Input Notes: 1. Parameter Ld.11 shows the unscaled value from the Analog Input selected as the Analog Level Input for ALM1. It has a range of: 819 @ 4.0mA & 4,095 @ 20mA. 2. The selected Analog Input must have its Analog Input Function set for Function 1.
Ld.12	-	-	42140	Analog Level Meter ALM1 - Scaled into feet.

ANALOG LEVEL METER - ALM2

Analog Level Meter ALM2 provides all the necessary logic and parameters to take the selected Analog Input's data and process it into a conditioned value scaled into feet and tenths of feet.

The 4-20mA signal from the Level Input device (typically a Pressure Transducer) must be connected to one of the Analog Inputs on the Controller. The Analog Input must be setup so that its data is sent to Analog Level Meter ALM2. To do this, the Analog Input selected for this task must have its Analog Input Setup parameter set for Function 2. See Parameters F.299 - F.308 in Section C. The value of the selected Analog Input in its unscaled form is displayed on Parameter Ld.21.

The logic in the Level Meter takes the value from Parameter Ld.21 and scales it to the Level Input Span (Parameter P.527). The finished value, scaled into feet and tenths of feet, is then made available to be viewed from Parameter Ld.22.

The **Level Input Span** (Parameter P.527) must be set to the calibrated span of the device providing the Level Input. This is the liquid level in feet that corresponds to a 20mA output from the Level Input device.

The **Level Input Zero** (Parameter P.528) is set at the factory so that with a 4.0mA Level Input the Level Meter displays 0.0 feet, with no negative sign. However, since Pressure Transducers and other Level Input devices are often not perfectly zeroed, the HMI provides UP and Down pushbuttons that allow an operator to make minor adjustments in the field to zero the Level Meter display. Before attempting to adjust the Level Input Zero, first pull the Submersible Pressure Transducer out of the liquid, or apply a 4.0mA signal to the Level Input, and then Set the Zero. When properly zeroed the Level Meter display should read 0.0 feet, with no negative sign.

The Signal Conditioning Control parameter (Parameter P.529) determines the speed at which the value displayed on Level Meter ALM2 may change in response to a change in the analog input signal. This is used to filter out sudden changes in the analog level input.

User / Operator Info.		SCADA		Description of Parameters and SCADA Notes
Parameter	Default Value	Current Value	Register Address	
Analog Level Meter ALM2 - Setup Parameters				
P.527	23.10 feet		40527	Analog Level Meter ALM2 - Level Input Span Range: 1.00 - 231.00 feet Note: Parameter P.527 must be set to the calibrated span of the device providing the Level.
P.528	-		40528	Analog Level Meter ALM2 - Level Input Zero Note: The HMI provides UP and Down pushbuttons that allow an operator to make minor adjustments in the field to Parameter P.528 while observing the Level from Parameter Ld.22.
P.529	240		40529	Analog Level Meter ALM2 - Signal Conditioning Control Range: 1 - 254 100 = Slow 240 = Normal 250 = Fast Note: This parameter controls the signal conditioning of Analog Level Meter ALM2
Analog Level Meter ALM2 - Data				
Ld.21	-	-	42141	Analog Level Meter ALM2 - Analog Level Input Notes: 1. Parameter Ld.21 shows the unscaled value from the Analog Input selected as the Analog Level Input for ALM2. It has a range of: 819 @ 4.0mA & 4,095 @ 20mA. 2. The selected Analog Input must have its Analog Input Function set for Function 2.
Ld.22	-	-	42142	Analog Level Meter ALM2 - Scaled into feet.

LEVEL DISPLAY SPAN VERSUS PRESSURE TRANSDUCER CALIBRATION

Transducer Calibration						
	5.0psi @ 20mA	10psi @ 20mA	15psi @ 20mA	30psi @ 20mA	60psi @ 20mA	100psi @ 20mA
Level Input Span	11.5 feet	23.1 feet	34.6 feet	69.3 feet	138.5 feet	230.9 feet

Notes:

1. Level Input Span is what is displayed with a 20mA Level Input.
2. To find the Level Input Span Setting for other transducers use the following equation:

$$\text{Pressure (psi)} \times 2.309 = \text{Level (feet of water)}$$

ANALOG LEVEL INPUT EXAMPLES - SINGLE TRANSDUCER

The Level Input Select (Parameter P.133) is used to select either Single or Dual Pressure Transducers as the Level Input. For more information about Parameter P.133 see pages 1-8, 2-9, 3-9 and X-5.

For information on using Dual Pressure Transducers see page M-5.

The examples below show the using of a Single Pressure Transducer, either Non-Isolated or Isolated.

Non-Isolated - Using the 24 VDC Power Supply on the SC5000

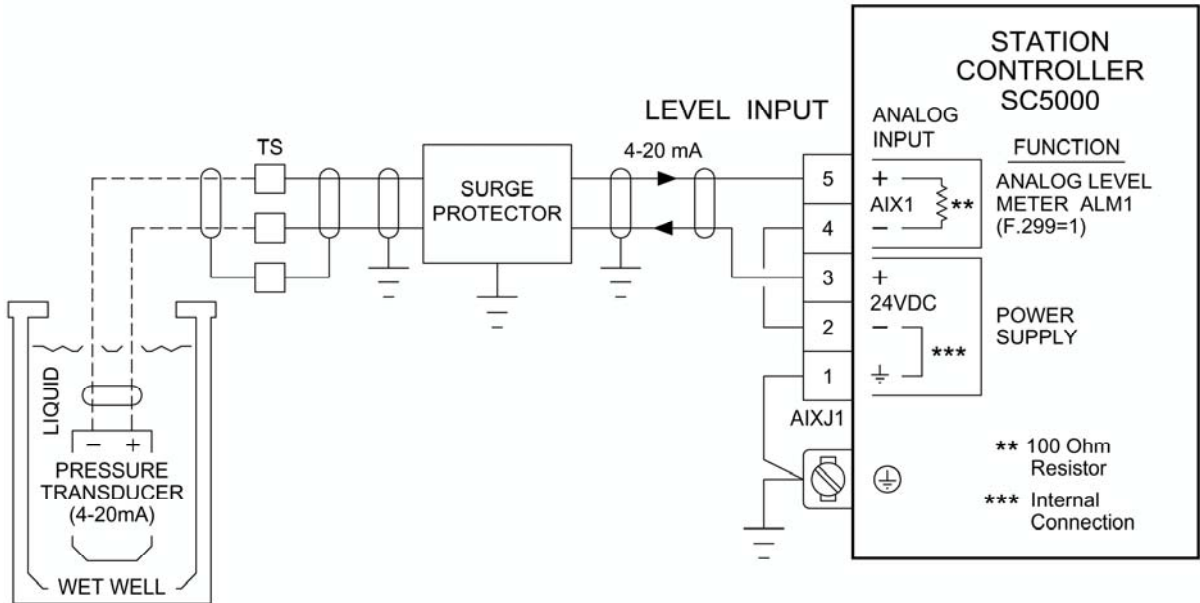

Isolated - Using an External 24VDC Power Supply

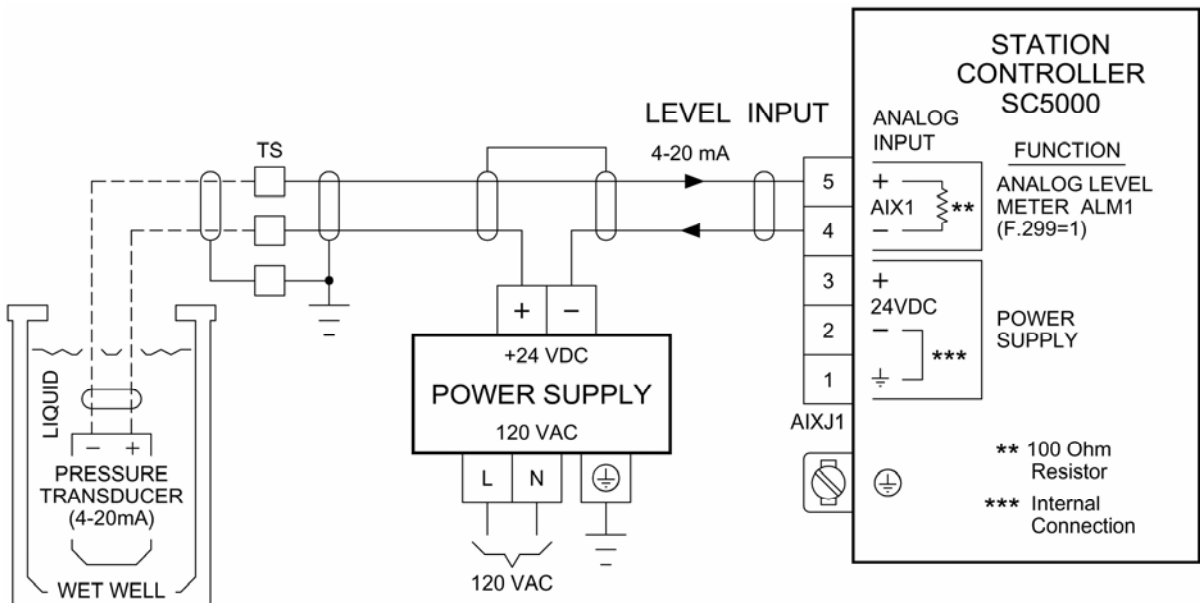

Notes:

1. All the Analog Inputs on the SC5000 are isolated from the SC5000's Power Supply ground and may be connected to remote devices that are at different ground potentials. However, if Isolation must be maintained an external Power Supply must be used.
2. The SC5000's 24 VDC Power Supply Commons (-), on AIXJ1 pin 2 and AIXJ2 pin 2, are internally connected to ground (not isolated from ground) and should not be used in cases where isolation of the 4-20mA signal must be maintained.

ANALOG LEVEL INPUT EXAMPLE - DUAL TRANSDUCERS

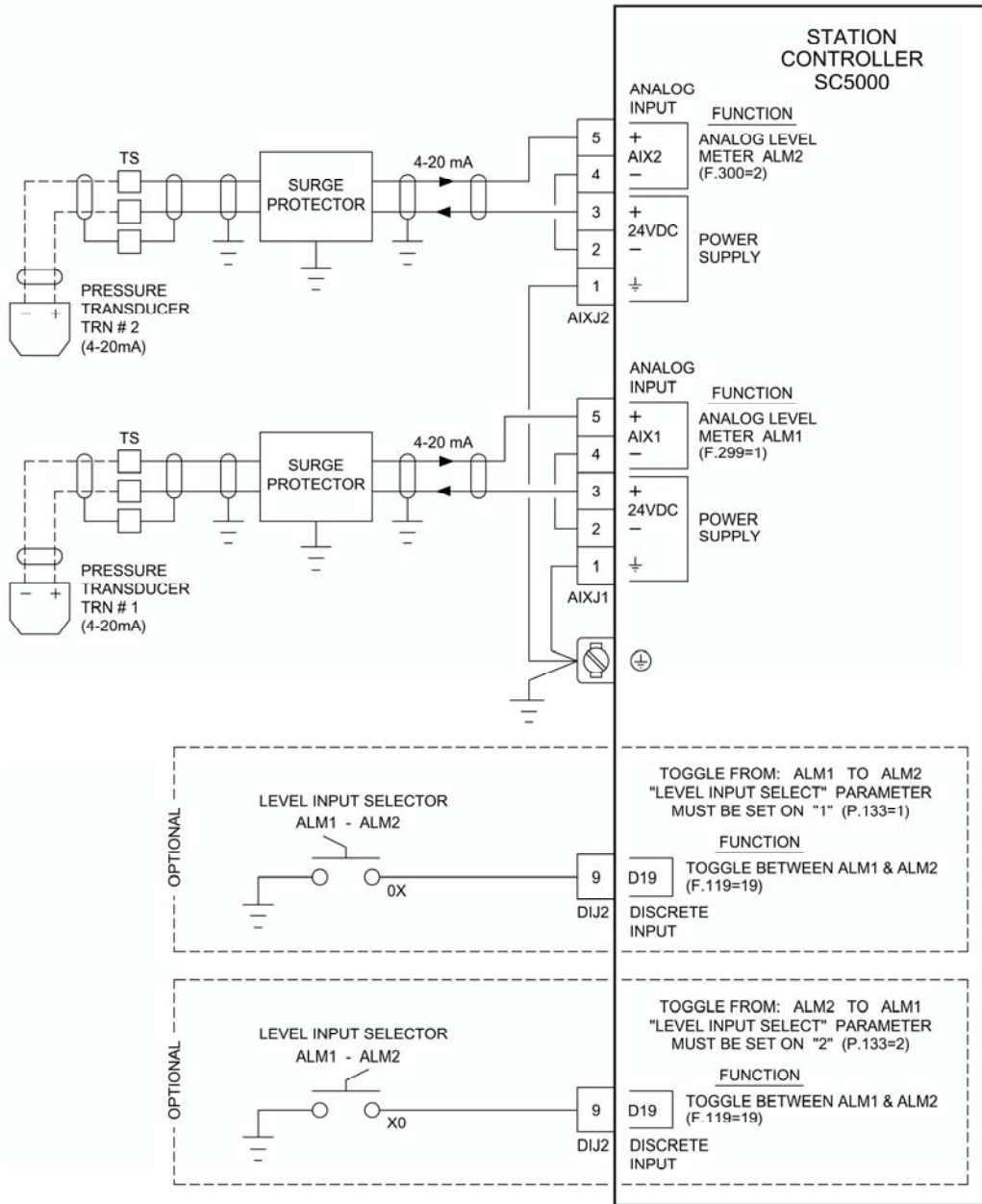

Dual Transducers for the Level Input

The Controller has available two Analog Level Meters ALM1 and ALM2 that may be setup and used to provide a Level Input to the Controller's Control Logic. Each of the two Level Meters must have their own Analog Level Input, typically from two Pressure Transducers. However, the Control Logic can only use one Level Input at a time.

Manually Toggle Between ALM1 & ALM2

A Discrete Input assigned the Function of "Toggle Between ALM1 & ALM2 for Level Input" (Function 19) may be used to manually toggle from ALM1 to ALM2 or from ALM2 to ALM1.

The setting on the "Level Input Select" (Parameter P.133) will determine the following operation:

- Level Input Select = 1 - Manually toggles from ALM1 to ALM2 when the Discrete Input closes.
- Level Input Select = 2 - Manually toggles from ALM2 to ALM1 when the Discrete Input closes.

Automatically Toggle Between ALM1 & ALM2

The Controller may be setup to automatically toggle between the two Analog Level Meters ALM1 and ALM2 upon a failure. Where the Failure of ALM1 or ALM2 is defined as the analog input being below 3.5 mA or above 21 mA. For a description of the Fault Codes generated by a failure of ALM1 or ALM2 see page F-2.

The setting on the "Level Input Select" (Parameter P.133) will determine the following operation:

- Level Input Select = 3 - Automatically toggles from ALM1 to ALM2 upon failure of ALM1.
- Level Input Select = 4 - Automatically toggles from ALM2 to ALM1 upon failure of ALM2.

ANALOG LEVEL METERS - Touchscreen HMI SCREENS



ANALOG LEVEL METER ALM1 - Scaling into Feet

[Previous Screen](#)

Analog Level Input
Analog Input Range:
819 @ 4.0mA
4095 @ 20mA
1234
Parameter: Ld.11

Analog Level Meter ALM1
123.4 feet
Parameter: Ld.12

Level Input Span
123.45 feet
Parameter: P.522

Level Input Zero
Slow 
Fast 
Parameter: P.523

Signal Conditioning Control
123
Parameter: P.524
100 = Slow
240 = Normal
250 = Fast

The Analog Input used to provide the Level Input must have its Analog Input Setup parameter set for Function 1, in order to be connected to the Analog Level Meter ALM1.



ANALOG LEVEL METER ALM2 - Scaling into Feet

[Previous Screen](#)

Analog Level Input
Analog Input Range:
819 @ 4.0mA
4095 @ 20mA
1234
Parameter: Ld.21

Analog Level Meter ALM2
123.4 feet
Parameter: Ld.22

Level Input Span
123.45 feet
Parameter: P.527

Level Input Zero
Slow 
Fast 
Parameter: P.528

Signal Conditioning Control
123
Parameter: P.529
100 = Slow
240 = Normal
250 = Fast

The Analog Input used to provide the Level Input must have its Analog Input Setup parameter set for Function 2, in order to be connected to the Analog Level Meter ALM2.