

# SC5000

## INSTRUCTION MANUAL

### SECTION 4

### BOOSTER CONTROL

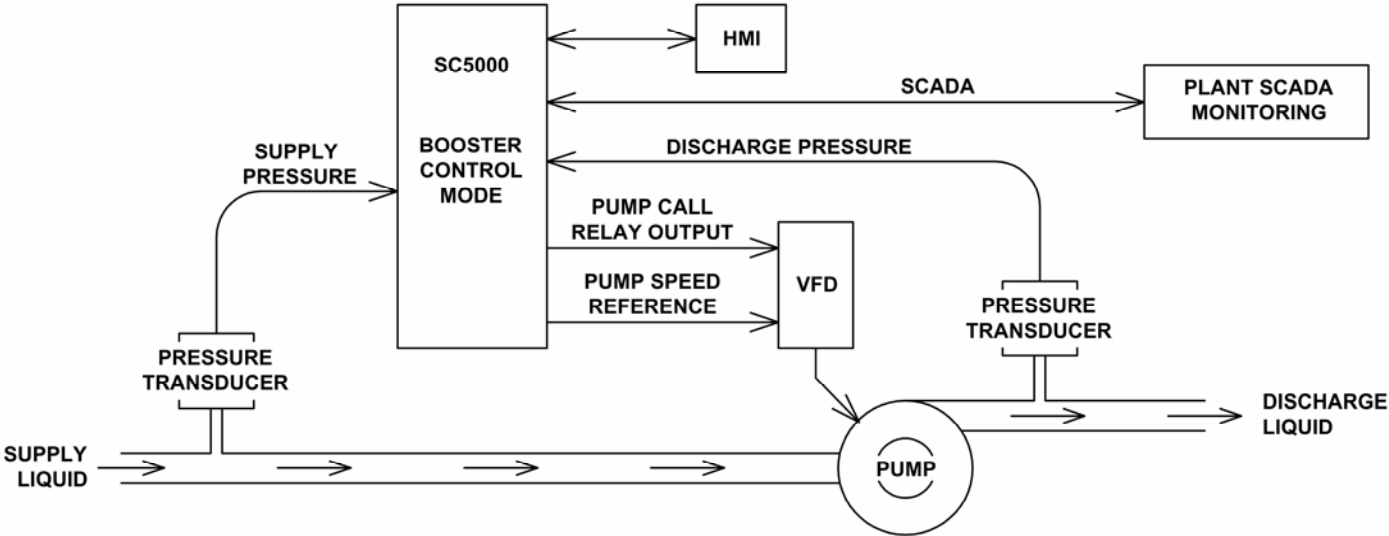

MOTOR PROTECTION ELECTRONICS, LLC

2464 Vulcan Road  
Apopka, Florida 32703

Phone: (407) 299-3825  
Website: [www.mpelectronics.com](http://www.mpelectronics.com)

# SECTION 4

## BOOSTER CONTROL

<b>TABLE OF CONTENTS</b>	<b>Page Number</b>
<b>DESCRIPTION OF FEATURES</b>	
Description of Features Available in the Booster Control Mode .....	4-2
<b>CONTROL SETUP &amp; DATA DISPLAY</b>	
Master Control Mode .....	4-6
Pump Setup .....	4-6
Elapsed Time Meter Data .....	4-6
Pump Alternation Setup and Status .....	4-7
Supply Pressure Input Setup and Data .....	4-8
Discharge Pressure Input Setup and Data .....	4-9
Discharge Pressure Setpoint .....	4-10
PID Controller Tuning .....	4-10
Pump Speed Reference Data .....	4-10
Turning On / Off of Pumps .....	4-11
Minimum Pump Speed .....	4-11
Pump Operation Enable / Disable .....	4-12
Discharge Pressure Setpoint Override - Upon Low Supply Pressure .....	4-13
Discharge Pressure Controlling Setpoint - During Start Up .....	4-14
First Pump Start Delay .....	4-15
Lag Pump Delay .....	4-15
Number of Pumps Required at Startup .....	4-15
Pump Speed Acceleration / Deceleration Rate.....	4-16
Supply Pressure Alarms .....	4-16
Discharge Pressure Alarms .....	4-16
Pump Alternation Sequence .....	4-17
Analog Pressure Meters APM1 and APM2 .....	N-1
<b>CONNECTION DIAGRAMS</b>	
Booster Control Example .....	4-18
Analog Pressure Input Examples .....	N-3
<b>HMI</b>	
SC5000-CTS-HMI Screens used for Booster Control .....	4-19

# BOOSTER CONTROL

## DESCRIPTION OF FEATURES

### General Description

With the Master Control Mode (Parameter P.091) set for “Booster Control” the SC5000 will function as a Booster Controller, and all logic pertaining to “Level Control”, “Flow Control” and “ Pressure Control” will be disabled.

In the Booster Control Mode, a PID Controller (Proportional, Integral, Derivative) is provided to regulate the pump speed in order to maintain the Discharge Pressure at the Discharge Pressure Setpoint.

The Booster Control logic also determines the number of pumps required to run in order to maintain the Discharge Pressure at the Discharge Pressure Setpoint.

The Booster Control logic also alternates the pumps and provides a First Pump Start Delay, Lag Pump Delay, Number of Pumps Required at Startup, Low Supply Pressure Alarm, High Supply Pressure Alarm, Low Discharge Pressure Alarm, and High Discharge Pressure Alarm. It also has parameters in the menu that allow the operator to set the Number of Pumps Present, the Maximum Number of Pumps Allowed to Run At the Same Time, and the Maximum Number of Pumps Allowed to Run While On a Generator.

The Booster Control Mode requires that each pump have its own VFD.

The Booster Control Mode also requires that the Controller be ordered with an optional Analog Output for each pump for the VFD speed reference (see Ordering Information).

### HMI Features

The **SC500-CTS-HMI** is a **Color Touch Screen HMI** programmed with screens that show the Supply Pressure, Discharge Pressure, Pump Speed Reference, Pump Run Status, Pump Available for Service indication, High Supply Pressure and Low Supply Pressure alarms, High Discharge Pressure and Low Discharge Pressure alarms, Discharge Pressure Setpoint Override Active indication, Supply Pressure Too Low For Pump Operation alarm, Elapsed Run Time meters for each pump, and any Fault Codes that may be present. All the control and alarm settings are made readily available to the operator for viewing or changing. An operator may also reset the Elapsed Run Time meters, and reset any Fault Codes.

### Discharge Pressure Setpoint

The Discharge Pressure Setpoint (Parameter P.489) must be set by the operator for the desired Discharge Pressure that the liquid should be pumped at as it leaves the pumping station.

At startup, the Booster Control logic will bring on the Number of Pumps Required at Startup (Parameter P.516). If number of pumps called at startup are unable to bring the Discharge Pressure up to the Discharge Pressure Setpoint, then another pump will be started. If the setpoint is still not reached, then the control logic will call another pump to run and then another until the Discharge Pressure Setpoint is met. Additionally, the logic will turn off any unneeded pumps.

The PID Controller will follow what is set on the Discharge Pressure Setpoint as it regulates the Discharge Pressure, except when the Supply Pressure is low. In this case the Controller will not strictly following the setpoint, but rather decrease the Discharge Pressure while the Supply Pressure is low, and follow the Discharge Pressure Setpoint when the Supply Pressure returns to the normal range.

### First Pump Start Delay

After power is applied to the Controller and after all the initial conditions are satisfied and the First Pump Start Delay (Parameter P.514) has expired, the Number of Pumps Required at Startup (Parameter P.516) will be started, and the Lag Pump Delay (Parameter P.515) will set the minimum time period between each pump call. The following are the initial conditions which must first be met for the First Pump Start Delay to begin timing out:

The Supply Pressure must be at or above the Pump Operation Enable Supply Pressure (Parameter P.503) and the Pump Operation Enable Delay (Parameter P.504) must have expired.

The “All Pump Disable” Discrete Input (Discrete Input Function 17) must be open.

At least one pump must be available for service (Not having its Pump Disable Discrete Input closed (Discrete Input Functions 11 - 16).

After all of the above conditions are met and the First Pump Start Delay times out, then the first pump will be started.

## **BOOSTER CONTROL**

### **Lag Pump Delay**

The Lag Pump Delay (Parameter P.515) sets the minimum time period between the calling of pumps to run at startup. It is also used to delay the turning on of the replacement pump when an operating pump is suddenly disabled, or when a time based alternation of the pumps is performed.

### **Number of Pumps Required at Startup**

The Number of Pumps Required at Startup (Parameter P.516) sets the minimum number of pumps that are initially turned on in order to meet the Discharge Pressure Setpoint. When the First Pump Start Delay (Parameter P.514) expires, the first of the required pumps will be turned on and each additional required pump will wait for the Lag Pump Delay (Parameter P.515) to expire.

### **Pump Turn On and Off**

#### **Operating Principal**

After the Number of Pumps Required at Startup (Parameter P.516) are started, the Booster Control logic will then control the number of additional pumps that are required to run in order to maintain the Discharge Pressure at the Discharge Pressure Setpoint. The control logic determines when an additional pump is needed and when to turn off an unneeded pump based on the following operating principal:

The number of pumps required to run is regulated so that the PID Controller does not drive the pump speed reference significantly higher than or lower than a predetermined pump speed range.

See graph on page 4-11.

#### **Turning On Pumps**

If at some point conditions in the system require that the pump speed be increased in order to maintain the Discharge Pressure Setpoint, then the pump speed reference will be increased as needed. If the pump speed reference were to be increased to the point that it were equal to or greater than what is set on the Pump Speed Upper Threshold (Parameter P.498), then one additional pump would be turned on, after the delay set on the Delay To Turn On One Pump (Parameter P.499) expires. This may be repeated again and again until all the available pumps are called to run, or until the pump speed becomes lower than the Pump Speed Upper Threshold (Parameter P.498).

#### **Turning Off Pumps**

If at some point in time the conditions in the system were to change such that a lower pump speed were required to maintain the Discharge Pressure Setpoint, then the pump speed reference would be decreased as needed. If the pump speed reference were to be decreased to the point where it was equal to or less than what is set on the Pump Speed Lower Threshold (Parameter P.500), then one of the pumps would be turned off, after the delay set on the Delay To Turn Off One Pump (Parameter P.501) expires. This may be repeated again and again until all but one pump is left running, or until the pump speed becomes higher than the Pump Speed Lower Threshold (Parameter P.500).

### **Pump Operation Enable / Disable**

The pump operation in the Booster Control Mode requires that there be adequate supply liquid pressure. The following two parameters provide the operator with control over how low the supply liquid pressure is allowed to drop before turning off all the pumps and at what pressure pumping should be allowed to resume:

See graph on page 4-12.

#### **Pump Operation Enable Supply Pressure**

To allow any pumps to start, the Supply Pressure (Parameter Pd.11) must first rise up to or be above what is set on the Pump Operation Enable Supply Pressure (Parameter P.503), and the Pump Operation Enable Delay (Parameter P.504) must have timed out.

#### **Pump Operation Disable Supply Pressure**

If the Supply Pressure (Parameter Pd.11) falls below what is set on the Pump Operation Disable Supply Pressure (Parameter P.505), and the Pump Operation Disable Delay (Parameter P.506) expires, then all the pumps will be turned off.

#### **Alarm Status**

When pump operation is disabled, based on Parameters P.505 and P.506, the "Supply Pressure Too Low for Pump Operation" alarm status bit will be set and may be read from Modbus Coil 259 (Register 40017 Bit 2).

## BOOSTER CONTROL

### Controlling Setpoint

At start up, to ensure the smooth stable control of the Discharge Pressure, the PID Controller is sent a gradually increasing Setpoint (the Controlling Setpoint (Parameter Pd.31)) that slowly increases to equal the Discharge Pressure Setpoint (Parameter P.489). The rate of the increase is set by the operator on the Discharge Pressure Ramp Rate (Parameter P.511). [See the graph on page 4-14.](#)

After start up, as long as the Supply Pressure remains in the normal range (above what is set on Parameter P.508), the Controlling Setpoint will be kept equal to the Discharge Pressure Setpoint and the PID Controller will regulate the pump speed to keep the Discharge Pressure at or near what is set on the Discharge Pressure Setpoint.

During start up or at any time, if the Supply Pressure becomes low (below what is set on Parameter P.508), then the value of the Controlling Setpoint will be ramped down along the linear slope established by Parameters P.507, P.508, P.509 and P.489. [See the graph on page 4-13.](#)

If while the pumps are operating and the Discharge Pressure Setpoint is changed by an operator, then the Controlling Setpoint will be ramped up or down to the new value of the Discharge Pressure Setpoint using the Discharge Pressure Ramp Rate (Parameter P.511).

While the Controlling Setpoint is being ramped up or down to the Discharge Pressure Setpoint, the “PID Controller Setpoint Override Active” status bit will be set and may be read from Modbus Coil 257 (Register 40017 Bit 0).

### Pump Alternation

#### Automatic Alternation

In the Booster Control Mode the pump Alternation Sequence Mode (Parameter P.122) is fixed to always be in the Standard Alternation, and the pumps will be Alternated “First On First Off”. [See page 4-7.](#)

[See the alternation sequence diagram on page 4-16.](#)

#### Manual Pump Call Sequence

When manual control over the pump call sequence is desired, the operator can use the Forced Lead Pump Position feature (Parameter P.129) to set the Lead Pump Position. This sets the order the pumps are called in. The Lead Pump Position may also be set using a Lead Pump Selector switch that is connected to Discrete Inputs assigned to Functions 31 - 36. [See page 4-7.](#)

[See connection diagrams on page A-13.](#)

#### Time Based Alternation

Time Based Alternation is also available in the Booster Control Mode. The Time Based Alternation logic may be triggered by an Internal Time Clock or from an External Time Clock. The Internal Time Clock alternation period is menu selectable (Parameter P.131). The External Time Clock may be triggered to alternate from either a External Time Clock connected to a Discrete Input on the Controller (assigned to Function 21), or it may be part of a SCADA system’s logic, where the SCADA system would set Modbus Coil 95 (Register 40006 Bit 14) to force the alternation of the pumps. [See page 4-7.](#)

### Supply Pressure Input Select

The Booster Control Mode requires that an analog Supply Pressure Input be provided to the Controller to monitor the Supply Pressure. The Supply Pressure Input Select (Parameter P.481) is provided to allow for the selection of either Analog Pressure Meter APM1, or APM2. [See Section N.](#)

### Discharge Pressure Input Select

The Booster Control Mode requires that an analog Discharge Pressure Input be provided to the Controller to monitor the Discharge Pressure. The Discharge Pressure Input Select (Parameter P.485) is provided to allow for the selection of either Analog Pressure Meter APM1, or APM2. [See Section N.](#)

# BOOSTER CONTROL

## Discrete Inputs

30 Discrete Inputs (D1 - D30) that may be setup to perform the following Functions:

- Pump Disable Inputs
- All Pump Disable - Phase Monitor Input
- On Generator - Limits number of pumps allowed to run
- External Alternation - External Time Clock Input
- Sequence Inputs - Lead Pump Selector Switch Inputs
- Call Pump Last Inputs
- Collection of Discrete Input Data for SCADA

## Relay Outputs

12 Relay Outputs (ROX1 - ROX12) that may be setup to perform the following Functions:

- Up to Six Pump Call to Run Outputs
- High or Low Supply Pressure Alarm Outputs
- High or Low Discharge Pressure Alarm Outputs
- SCADA Remote Control Outputs

## Analog Inputs

2 Standard Analog Inputs (AIX1 - AIX2) and up to 8 more Optional Analog Inputs (A1 - A8).

The Analog Inputs may be setup to perform one of the following Functions:

- Analog Flow Meter AFM1, AFM2 or AFM3
- Analog Pressure Meter APM1 or APM2
- Analog Current Meter ACMA, ACMB or ACMC
- Collection of Analog Input Data for SCADA

## Analog Outputs

1 Standard Analog Output (AOX1) and up to 6 more Optional Analog Outputs (AO1 - AO6).

The Analog Outputs may be setup to perform one of the following Functions:

- Analog Signal for Pumps 1 - 6 Speed Reference
- Analog Signal for Pumps Speed Reference any Pump (Always Active)

## Pulse Counter Inputs

Option for up to 3 Pulse Counter Inputs (DPC1 - DPC3) that may be used to perform the following:

- Pulse Counter Input for Pulse Flow Meter PFM1, PFM2 or PFM3

## BOOSTER CONTROL

User / Operator Info.			SCADA	Description of Parameters and SCADA Notes
Parameter	Default Value	Current Value	Register Address	
<b>Master Control Mode</b>				
P.091	1		40091	Master Control Mode 1 = Level Control 2 = Flow Control 3 = Pressure Control 4 = Booster Control <b>Must Be Set On "4" for Booster Control</b>
<b>Pump Setup</b>				
P.092	6		40092	Number of Pumps Present 1 = 1 Pump    2 = 2 Pumps    3 = 3 Pumps 4 = 4 Pumps    5 = 5 Pumps    6 = 6 Pumps
P.093	6		40093	Maximum Number of Pumps Allowed to Run at the Same Time 1 = 1 Pump    2 = 2 Pumps    3 = 3 Pumps 4 = 4 Pumps    5 = 5 Pumps    6 = 6 Pumps
P.094	6		40094	Maximum Number of Pumps Allowed to Run While On Generator 1 = 1 Pump    2 = 2 Pumps    3 = 3 Pumps 4 = 4 Pumps    5 = 5 Pumps    6 = 6 Pumps Note: Must Connect Transfer Switch Contact to Discrete Input assigned to Function 18.

User / Operator Info.		SCADA	Description of Data
Parameter	Register Address		
<b>Elapsed Time Meter Data</b>			
Etd.1	41891	Pump 1 - Elapsed Time Meter (hours and 1/10 hours)	Range: 0.0 - 6553.5 hours
Etd.2	41892	Pump 2 - Elapsed Time Meter (hours and 1/10 hours)	Range: 0.0 - 6553.5 hours
Etd.3	41893	Pump 3 - Elapsed Time Meter (hours and 1/10 hours)	Range: 0.0 - 6553.5 hours
Etd.4	41894	Pump 4 - Elapsed Time Meter (hours and 1/10 hours)	Range: 0.0 - 6553.5 hours
Etd.5	41895	Pump 5 - Elapsed Time Meter (hours and 1/10 hours)	Range: 0.0 - 6553.5 hours
Etd.6	41896	Pump 6 - Elapsed Time Meter (hours and 1/10 hours)	Range: 0.0 - 6553.5 hours

## BOOSTER CONTROL

User / Operator Info.			SCADA	Description of Parameters and SCADA Notes
Parameter	Default Value	Current Value	Register Address	
<b>Pump Alternation Setup</b>				
P.122	1	1	40122	<p>Alternation Sequence Mode <span style="float: right;">See page 4-17.</span></p> <p>1 = Standard Alternation of Pumps 1 - 6</p> <p>Note: With the Master Control Mode set on Booster Control the Alternation Sequence Mode will be fixed on Standard Alternation.</p>
P.129	0		40129	<p>Forced Lead Pump Position</p> <p>0 = Normal Alternation    X = Pump X as Lead</p>
P.131	0		40131	<p>Time Based Alternation <span style="float: right;">Range: 0 - 65535 minutes</span></p> <p>0 = Disabled    60 = 1 hour    480 = 8 hours    1440 = 24 hours</p> <p>Note: Pump Alternation may be triggered using the Internal Time Clock setup using Parameter P.131, or it can also be triggered by an External Time Clock, which may be either a hardware device connected to a Discrete Input setup to perform Function 21, or it may be triggered by having the SCADA system set Bit 14 in Register 40006.</p>
<b>Pump Alternation Status</b>				
Ad.01	-	-	41888	<p>Current Lead Pump    Shows the number of the current Lead Pump.</p>



## BOOSTER CONTROL

User / Operator Info.		SCADA		Description of Parameters and SCADA Notes
Parameter	Default Value	Current Value	Register Address	
<b>Supply Pressure Input Setup</b>				
<b>P.481</b>	1		40481	<p>Supply Pressure Input Select</p> <p>1 = Analog Pressure Meter APM1      2 = Analog Pressure Meter APM2</p> <p>Note: This parameter establishes which Analog Pressure Meter's data will be used as the Supply Pressure. The Supply Pressure data selected here is available to be read from Parameters Pd.11 and Pd.12. See Section N.</p>
<b>P.482</b>	100.0 psi		40482	<p>Supply Pressure Bar Graph Span</p> <p>Note: This parameter sets the span of the Supply Pressure Bar Graph for Parameter Pd.12.</p>
<b>Supply Pressure Data</b>				
<b>Pd.11</b>	-	-	42229	<p>Supply Pressure Data - For Numerical Display of Supply Pressure</p> <p>Note: This is the value of the Supply Pressure data selected on Parameter P.481 scaled into psi for numerical display.</p>
<b>Pd.12</b>	-	-	42230	<p>Supply Pressure Data - For Bar Graph Display of Supply Pressure</p> <p>Note: This is the value of the Supply Pressure data selected on Parameter P.481 scaled for display on a bar graph. It is scaled to a range of 0 - 4095 by using the "Supply Pressure Bar Graph Span" (Parameter P.482). The Bar Graph Display scaling setup on the HMI device must be set for 0 - 4095.</p>

## BOOSTER CONTROL

User / Operator Info.			SCADA	Description of Parameters and SCADA Notes
Parameter	Default Value	Current Value	Register Address	
<b>Discharge Pressure Input Setup</b>				
<b>P.485</b>	2		40485	Discharge Pressure Input Select 1 = Analog Pressure Meter APM1      2 = Analog Pressure Meter APM2 Note: This parameter establishes which Analog Pressure Meter's data will be used as the Discharge Pressure. The Discharge Pressure data selected here is available to be read from Parameters Pd.21 and Pd.22. See Section N.
<b>P.486</b>	100.0 psi		40486	Discharge Pressure Bar Graph Span Note: This parameter sets the span of the Discharge Pressure Bar Graph for Parameter Pd.22.
<b>Discharge Pressure Input Data</b>				
<b>Pd.21</b>	-	-	42231	Discharge Pressure Data - For Numerical Display of Discharge Pressure Note: This is the value of the Discharge Pressure data selected on Parameter P.485 scaled into psi for numerical display.
<b>Pd.22</b>	-	-	42232	Discharge Pressure Data - For Bar Graph Display of Discharge Pressure Note: This is the value of the Discharge Pressure data selected on Parameter P.485 scaled for display on a bar graph. It is scaled to a range of 0 - 4095 by using the "Discharge Pressure Bar Graph Span" (Parameter P.486). The Bar Graph Display scaling setup on the HMI device must be set for 0 - 4095.

## BOOSTER CONTROL

User / Operator Info.		SCADA		Description of Parameters and SCADA Notes
Parameter	Default Value	Current Value	Register Address	
<b>Discharge Pressure Setpoint</b>				
<b>P.489</b>	60.0 psi		40489	<p>Discharge Pressure Setpoint (SP) <span style="float: right;">Range: 3.0 - 300.0 psi</span></p> <p>Note: This is the parameter that sets the desired Discharge Pressure of the liquid being pumped.</p>
<b>Pd.31</b>	-		42233	<p>Controlling Setpoint</p> <p>Note: To ensure a smooth stable control of the Discharge Pressure during startup, the value of the Controlling Setpoint (Parameter Pd.31) sent to the PID Controller is ramped up to the value set on the Discharge Pressure Setpoint (Parameter P.489), using the ramp rate set on the Discharge Pressure Ramp Rate (Parameter P.511).</p> <p>If while in operation, the Supply Pressure becomes low (below what is set on Parameter P.508), then the value of the Controlling Setpoint will be ramped down along the linear slope established by Parameters P.507, P.508, P.509 and P.489, as shown on page 4-13. The rate at which it is ramped down (or up) the slope is set on the Discharge Pressure Ramp Rate (Parameter P.511), as shown on page 4-14.</p>
<p>At startup or at any time the Setpoint Override logic keeps the Controlling Setpoint from being equal to the Discharge Pressure Setpoint, the "PID Controller Setpoint Override Active" status bit will be set. Its status may be read from Modbus Coil 257 (Register 40017 Bit 0).</p>				
<b>PID Controller Tuning</b>				
<b>P.491</b>	1.60		40491	<p>Controller Gain (Kc) <span style="float: right;">Range: 0.01 - 30.00</span></p> <p>Note: This parameter is used to tune the proportional component of the PID Controller's Pump Speed Reference output.</p>
<b>P.492</b>	0.02 minutes / repeat		40492	<p>Integral Time (Ti) <span style="float: right;">Range: 0.01 - 60.00 minutes / repeat</span></p> <p>Note: This parameter is used to tune the integral component of the PID Controller's Pump Speed Reference output. Changes to this parameter may result in significant changes to the Pump Speed Reference. Therefore, it is recommended that only small changes are made to this parameter while the system is in operation.</p>
<b>P.493</b>	0.00 minutes		40493	<p>Derivative Time (Td) <span style="float: right;">Range: 0.00 - 2.00 minutes</span></p> <p>Note: This parameter is used to tune the derivative component of the PID Controller's Pump Speed Reference output.</p>
<b>Pump Speed Reference Data</b>				
<b>Pd.41</b>	-		41877	<p>Pump Speed Reference Data <span style="float: right;">Range: 0.0 - 100.0 percent</span></p> <p>Notes:</p> <ol style="list-style-type: none"> <li>1. The Pump Speed Reference is determined by the PID Controller and is sent to the VFDs, as a 4-20mA signal, to control the pump speed</li> <li>2. All operating pumps receive the same Speed Reference.</li> <li>3. Parameter Pd.41 is the Pump Speed Reference as a percent of full speed.</li> </ol>

# BOOSTER CONTROL

## Turning On / Off Pumps

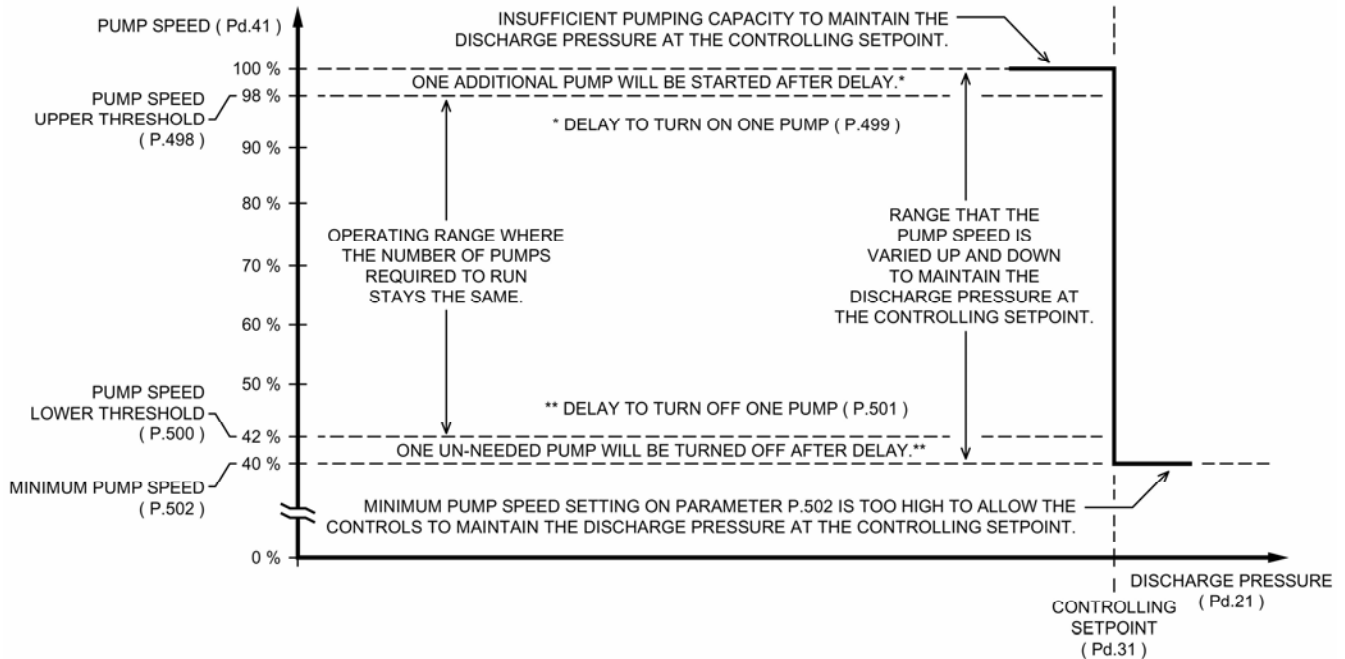

User / Operator Info.			SCADA	Description of Parameters and SCADA Notes
Parameter	Default Value	Current Value	Register Address	
<b>Turning On of Pumps</b>				
<b>P.498</b>	98.0 %		40498	<b>Pump Speed Upper Threshold</b> Range: 30.0% - 100.0% of Full Speed Note: When the Pump Speed Reference has increased to where it is greater than or equal to what is set on this parameter, the <b>Delay To Turn On One Pump</b> (Parameter P.499) is started. When the delay expires an additional pump will be turned on.
<b>P.499</b>	10 sec.		40499	<b>Delay To Turn On One Pump</b> Range: 1 - 600 seconds Note: This delay starts when the Pump Speed Reference has increased to where it is greater than or equal to the <b>Pump Speed Upper Threshold</b> (Parameter P.498). When the delay expires an additional pump will be turned on.
<b>Turning Off of Pumps</b>				
<b>P.500</b>	42.0 %		40500	<b>Pump Speed Lower Threshold</b> Range: 10.0% - 90.0% of Full Speed Note: When the Pump Speed Reference has decreased to where it is less than or equal to what is set on this parameter, the <b>Delay To Turn Off One Pump</b> (Parameter P.501) is started. When the delay expires one pump will be turned off.
<b>P.501</b>	10 sec.		40501	<b>Delay To Turn Off One Pump</b> Range: 1 - 600 seconds Note: This delay starts when the Pump Speed Reference has decreased to where it is less than or equal to the <b>Pump Speed Lower Threshold</b> (Parameter P.500). When the delay expires one pump will be turned off.
<b>Minimum Pump Speed</b>				
<b>P.502</b>	40%		40502	<b>Minimum Pump Speed</b> Range: 0% - 95% of full speed Note: For each application there is usually a minimum speed, below which pump operation is undesirable. This parameter sets the minimum pump speed allowed. With a <b>Minimum Pump Speed</b> set on Parameter P.502, care must be taken that there is not also a minimum speed set on the VFDs.

## BOOSTER CONTROL

### Pump Operation Enable / Disable

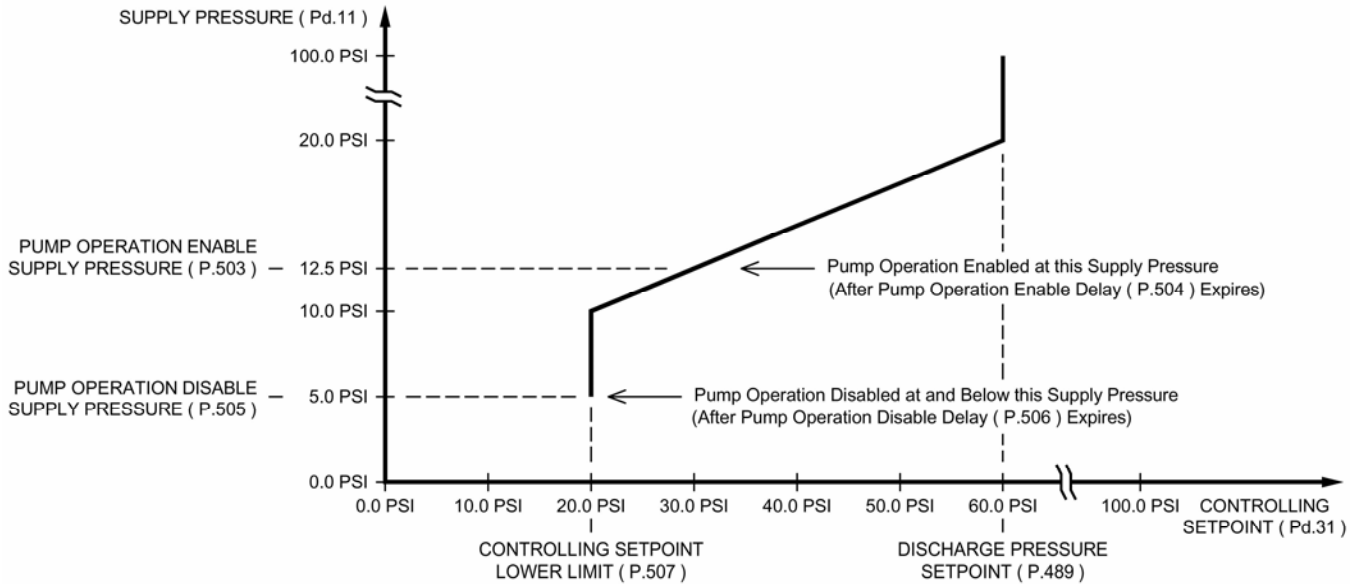

#### Supply Pressure Required to Enable Pump Operation

Due to the risk of a Low Supply Pressure condition causing cavitation of the pumps, the control logic always monitors the Supply Pressure looking for a Low Supply Pressure condition.

To prevent cavitation of the pumps it is critical to select values for Parameters P.503 and P.505 which ensure that there is always an adequate Supply Pressure.

The purpose of the graph above is to point out the relationship between the Pump Operation Enable and Disable Parameters (P.503 and P.505) and the Discharge Pressure Setpoint Override Ramp, which will be discussed on the next page.

The Pump Operation Enable Supply Pressure (Parameter P.503) may be located higher or lower than what is shown above, but it must always be set higher than the Pump Operation Disable Supply Pressure (Parameter P.505).

User / Operator Info.			SCADA	Description of Parameters and SCADA Notes
Parameter	Default Value	Current Value	Register Address	
<b>Pump Operation Enable</b>				
<b>P.503</b>	12.5 psi		40503	Pump Operation Enable Supply Pressure Range: 3.0 - 300.0 psi Note: This is the Supply Pressure at which pump operation will be enabled and the first pump started, after the delay set on the <b>Pump Operation Enable Delay</b> (Parameter P.504) expires.
<b>P.504</b>	10 sec.		40504	Pump Operation Enable Delay Range: 1 - 300 seconds Note: This delay starts when the Supply Pressure has risen enough to be greater than or equal to the <b>Pump Operation Enable Supply Pressure</b> (Parameter P.503).
<b>Pump Operation Disable</b>				
<b>P.505</b>	5.0 psi		40505	Pump Operation Disable Supply Pressure Range: 3.0 - 300.0 psi Note: This is the Supply Pressure at or below which all pumps will be turned off, after the delay set on the <b>Pump Operation Disable Delay</b> (Parameter P.506) expires.
<b>P.506</b>	10 sec.		40506	Pump Operation Disable Delay Range: 1 - 300 seconds Note: This delay starts when the Supply Pressure has decreased to where it is less than or equal to the <b>Pump Operation Disable Supply Pressure</b> (Parameter P.505).
When pump operation is disabled, based on Parameters P.505 and P.506, the "Supply Pressure Too Low for Pump Operation" status bit will be set. Its status may be read from Modbus Coil 259 (Register 40017 Bit 2).				

## BOOSTER CONTROL

### Discharge Pressure Setpoint Override - Upon Low Supply Pressure

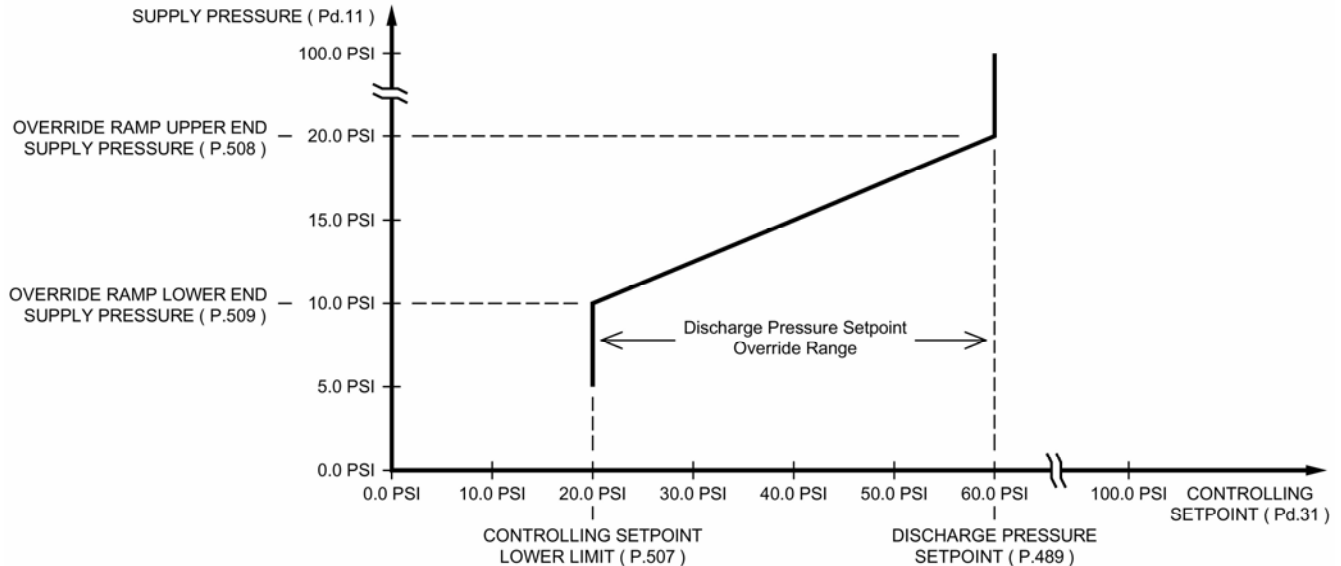

### Discharge Pressure Setpoint Override - Upon a Low Supply Pressure

Upon a low Supply Pressure condition, where the Supply Pressure is lower than what is set on Parameter P.508, the Setpoint Override logic will ramp down the Controlling Setpoint as shown in the graph above. This must be done to prevent the Supply Pressure from becoming too low, risking cavitation of the pumps.

Upon a low Supply Pressure condition the Discharge Pressure Setpoint Override logic makes the Controlling Setpoint (Pd.31) lower (or much lower) than the Discharge Pressure Setpoint (P.489). Then the PID Controller responds by ramping down the Pump Speed Reference (Pd.41). The reduced pump speed would then allow the Supply Pressure to either rise or to not go any lower.

If the low Supply Pressure condition requires that the Pump Speed Reference (Pd.41) be decreased to the point where it is less than or equal to Parameter P.500, for the time set on Parameter P.501, then the control logic will turn off one or more of the pumps. See Parameters P.500 and P.501 on page 4-11.

User / Operator Info.			SCADA	Description of Parameters and SCADA Notes
Parameter	Default Value	Current Value	Register Address	
<b>Controlling Setpoint Lower Limit</b>				
<b>P.507</b>	20.0 psi		40507	Controlling Setpoint Lower Limit Range: 3.0 - 300.0 psi Note: Parameter P.507 sets the lowest value that the Setpoint Override logic is allowed to make the Controlling Setpoint.
<b>Override Ramp Upper End Supply Pressure</b>				
<b>P.508</b>	20.0 psi		40508	Override Ramp Upper End Supply Pressure Range: 3.0 - 300.0 psi Note: Parameter P.508 sets the Supply Pressure that corresponds to where the Setpoint Override logic makes the Controlling Setpoint equal to the Discharge Pressure Setpoint (Parameter P.489).
<b>Override Ramp Lower End Supply Pressure</b>				
<b>P.509</b>	10.0 psi		40509	Override Ramp Lower End Supply Pressure Range: 3.0 - 300.0 psi Note: Parameter P.509 sets the Supply Pressure that corresponds to where the Setpoint Override logic makes the Controlling Setpoint equal to the Controlling Setpoint Lower Limit (Parameter P.507).
At startup or at any time the Setpoint Override logic keeps the Controlling Setpoint from being equal to the Discharge Pressure Setpoint, the "PID Controller Setpoint Override Active" status bit will be set. Its status may be read from Modbus Coil 257 (Register 40017 Bit 0).				

## BOOSTER CONTROL

### Discharge Pressure Controlling Setpoint - During Start Up

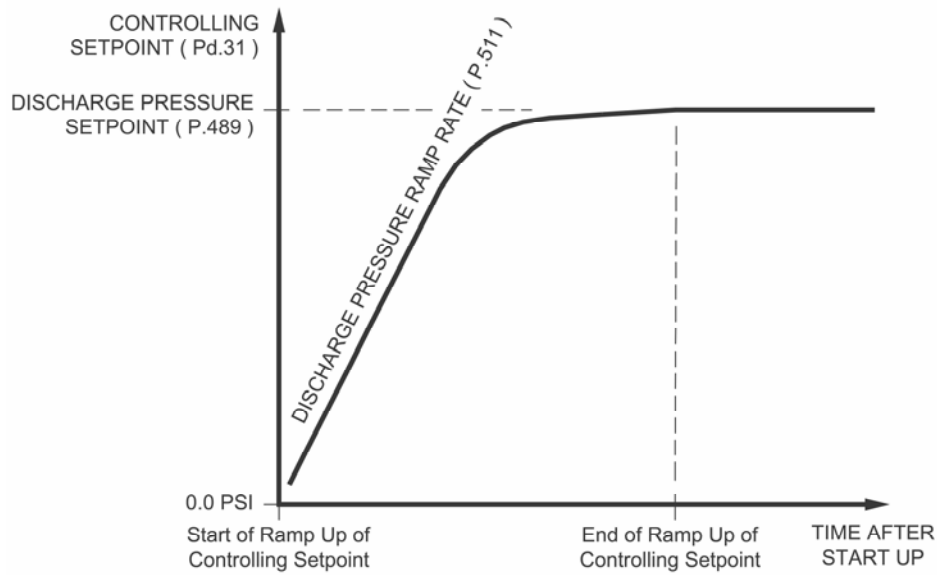

#### Start Up

During start up, the volume being pumped must not be increased too quickly, as this may cause the Supply Pressure to drop too low. To prevent this issue, the Booster Control logic slowly ramps up the Discharge Pressure Controlling Setpoint during start up. The Discharge Pressure Ramp Rate (Parameter P.511) is provided to set the start up ramp rate.

During start up, with adequate Supply Pressure, the Controlling Setpoint (Parameter Pd.31) that is sent to the PID Controller is slowly ramped up until it matches the Discharge Pressure Setpoint (Parameter P.489), following the curve shown above.

However, if during startup the Supply Pressure drops below what is set on the Override Ramp Upper End Supply Pressure (Parameter P.508), the control logic will reduce the Controlling Setpoint (Pd.31) as shown in the graph on page 4-13.

During start up, for the first 80% of the way to the Discharge Pressure Setpoint, the Controlling Setpoint is increased at the rate set on the Discharge Pressure Ramp Rate (Parameter P.511). Then, for the last 20% of the way to the Discharge Pressure Setpoint, the ramp rate is slowly decreased, as shown above.

The decrease in the ramp rate at the end of the curve shown above, is to reduce the overshooting of the Discharge Pressure Setpoint at start up.

At start up, if the Discharge Pressure is excessively overshooting the Discharge Pressure Setpoint, reduce the setting on the Discharge Pressure Ramp Rate (Parameter P.511), until the overshooting is within acceptable limits.

User / Operator Info.			SCADA	Description of Parameters and SCADA Notes
Parameter	Default Value	Current Value	Register Address	
<b>Discharge Pressure Ramp Rate</b>				
<b>P.511</b>	1.00 psi /sec		40511	Discharge Pressure Ramp Rate <span style="float: right;">Range: 0.10 - 10.00 psi / sec</span> Note: Parameter P.511 sets the initial rate at which the control logic is allowed to change the Discharge Pressure's Controlling Setpoint (Parameter Pd.31). Parameter P.511 must be set so that during start up the Supply Pressure is not made to drop too low. The ramp rate setting may be further decreased in order to reduce the overshooting of the Discharge Pressure Setpoint at start up.
At startup or at any time the Setpoint Override logic keeps the Controlling Setpoint from being equal to the Discharge Pressure Setpoint, the "PID Controller Setpoint Override Active" status bit will be set. Its status may be read from Modbus Coil 257 (Register 40017 Bit 0).				

## BOOSTER CONTROL

User / Operator Info.		SCADA		Description of Parameters and SCADA Notes
Parameter	Default Value	Current Value	Register Address	
<b>First Pump Start Delay</b>				
<b>P.514</b>	10 sec.		40514	<p>First Pump Start Delay <span style="float: right;">Range: 1 - 180 seconds</span></p> <p>Note: The First Pump Start Delay period starts when all the following conditions are met:</p> <ol style="list-style-type: none"> <li>1. Power is applied to Controller.</li> <li>2. The Supply Pressure is at or above the Pump Operation Enable Supply Pressure (Parameter P.503) and the Pump Operation Enable Delay (Parameter P.504) has expired.</li> <li>3. The "All Pump Disable" discrete input (Discrete Input Function 17) is open.</li> <li>4. At least one Pump is available for service and has its "Pump Disable" discrete input (Discrete Input Functions 11 - 16) open.</li> </ol>
<b>Lag Pump Delay</b>				
<b>P.515</b>	5 sec.		40515	<p>Lag Pump Delay <span style="float: right;">Range: 1 - 100 seconds</span></p> <p>Note: This is the minimum time period between the calling of pumps to run at startup. It is also used to delay the turning on of the replacement pump when an operating pump is suddenly disabled, or when a time based alternation of the pumps is performed.</p>
<b>Number of Pumps Required at Startup</b>				
<b>P.516</b>	1		40516	<p>Number of Pumps Required at Startup <span style="float: right;">Range: 1 - 6</span></p> <p>Note: This is the minimum number of pumps that are initially turned on in order to meet the Discharge Pressure Setpoint. When the First Pump Start Delay (Parameter P.514) expires, the first required pump will be turned on and each additional required pump will wait for the Lag Pump Delay (Parameter P.515) to expire.</p>



## BOOSTER CONTROL

User / Operator Info.		SCADA		Description of Parameters and SCADA Notes
Parameter	Default Value	Current Value	Register Address	
<b>Pump Speed Acceleration / Deceleration Rate</b>				
<b>P.166</b>	30 sec.		40166	<p>Pump Speed Acceleration Rate    Range: 1 - 100 seconds / 100% speed</p> <p>Notes:</p> <ol style="list-style-type: none"> <li>When a pump is turned on, this is the rate at which the pump's Speed Reference will be increased until it matches the Pump Speed Reference produced by the PID Controller (Parameter Pd.41). This is also the rate at which a pump's Speed Reference will follow increases of the Pump Speed Reference produced by the PID Controller.</li> <li>The setting on Parameter P.166 is the time required for a pump's Speed Reference to go from 0% - 100%.</li> <li>The Controller performs the Acceleration of the pump speed of the individual pumps. Therefore, the Accel Parameter on the VFDs should be set to a value less than or equal to what is set on Parameter P.166.</li> </ol>
<b>P.167</b>	30 sec.		40167	<p>Pump Speed Deceleration Rate    Range: 1 - 100 seconds / 100% speed</p> <p>Notes:</p> <ol style="list-style-type: none"> <li>When a pump is turned off, this is the rate at which the pump's Speed Reference will be decreased to 0% speed. This is also the rate at which a pump's Speed Reference will follow decreases of the Pump Speed Reference produced by the PID Controller.</li> <li>The setting on Parameter P.167 is the time required for a pump's Speed Reference to go from 100% - 0%.</li> <li>When a pump is turned off, the pump's Control Relay contact will be kept closed during the Deceleration of the pump to 0% speed, then the contact will be opened.</li> <li>The Controller performs the Deceleration of the pump speed of the individual pumps. Therefore, the Decel Parameter on the VFDs should be set to a value less than or equal to what is set on Parameter P.167.</li> </ol>
<b>Supply Pressure Alarms</b>				
<b>P.391</b>	5.0 psi		40391	<p>Low Supply Pressure Alarm    Range: 0.0 - 300.0 psi</p> <p>Note: Upon a Low Supply Pressure Alarm, the contacts of a relay assigned to Function 11 will close.</p>
The "Low Supply Pressure Alarm" status is available from Modbus Coil 265 (Register 40017 Bit 8).				
<b>P.392</b>	50.0 psi		40392	<p>High Supply Pressure Alarm    Range: 0.1 - 300.0 psi</p> <p>Note: Upon a High Supply Pressure Alarm, the contacts of a relay assigned to Function 12 will close.</p>
The "High Supply Pressure Alarm" status is available from Modbus Coil 266 (Register 40017 Bit 9).				
<b>Discharge Pressure Alarms</b>				
<b>P.393</b>	20.0 psi		40393	<p>Low Discharge Pressure Alarm    Range: 0.0 - 300.0 psi</p> <p>Note: Upon a Low Discharge Pressure Alarm, the contacts of a relay assigned to Function 13 will close.</p>
The "Low Discharge Pressure Alarm" status is available from Modbus Coil 267 (Register 40017 Bit 10).				
<b>P.394</b>	70.0 psi		40394	<p>High Discharge Pressure Alarm    Range: 0.1 - 300.0 psi</p> <p>Note: Upon a High Discharge Pressure Alarm, the contacts of a relay assigned to Function 14 will close.</p>
The "High Discharge Pressure Alarm" status is available from Modbus Coil 268 (Register 40017 Bit 11).				

# PUMP ALTERNATION SEQUENCE

## STANDARD ALTERNATION

Parameter P.122 = 1

With the Master Control Mode set on Booster Control the Alternation Sequence Mode will be fixed on Standard Alternation (Parameter P.122 = 1).

The pumps will be Alternated “First On First Off”.

Discrete Inputs assigned the Function of “Pump Disable” (Functions 11 - 16) inputs may be used to disable pumps so that they will not be called to run.

Discrete Inputs assigned the Function of “Call Pump Last” (Functions 41 - 46) may be used to assign pumps to standby status, where they will only be called to run if no other pumps are available.

Discrete Inputs assigned the Function of “Sequence Input” (Functions 31 - 36) may be used to set the lead pump.

The “Forced Lead Pump Position” (Parameter P.129) may be used to set the lead pump.

“Time Based Alternation” (Parameter P.131) may be setup to force an alternation using an Internal Time Clock.

A Discrete Input assigned the Function of “External Alternation” (Function 21) may be connected to an External Time Clock and used to force an alternation.

A SCADA system may initiate an alternation by momentarily setting Modbus Coil 95 (Register 40006, Bit 14).

## Movement of Lead Pump Upon Alternation

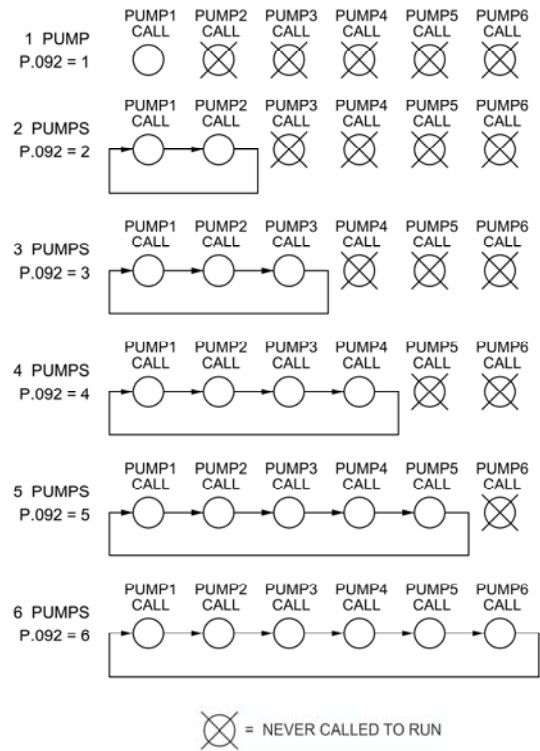

# BOOSTER CONTROL EXAMPLE

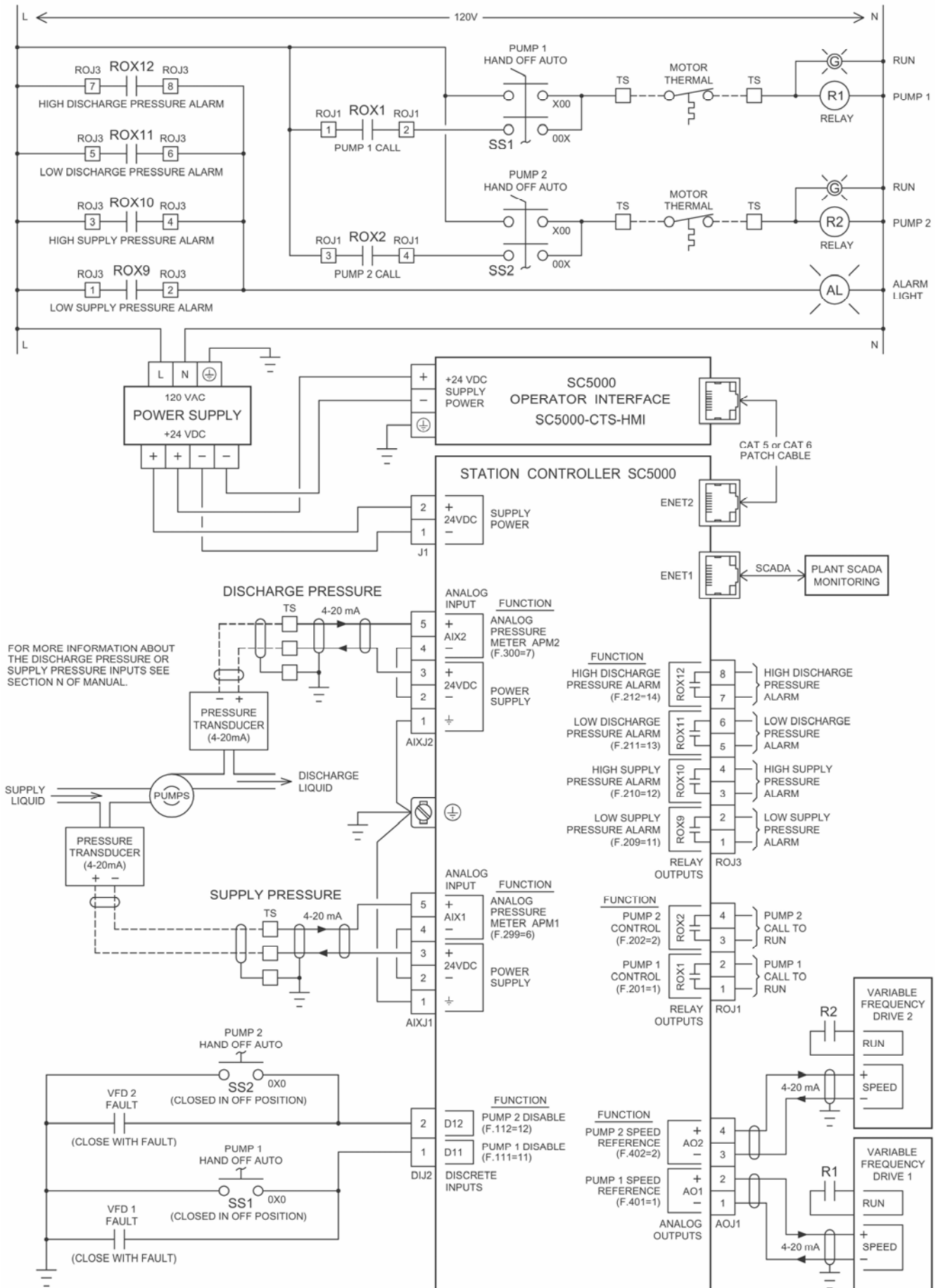

# BOOSTER CONTROL - Touchscreen HMI SCREENS

## Main Screen

STATION CONTROLLER SC5000

**Fault Code**  
FLC 1234  
LFC 1234  
Reset

**Control Mode Select**  
Pump Setup  
Security Setup  
SCADA Setup  
Backup / Restore

**Parameter Security**  
PARAMETERS UNLOCKED  
Security Code Entry

**I / O**  
Discrete Inputs  
Relay Outputs  
Analog Inputs  
Analog Outputs

**Meters**  
Level  
Pressure  
Flow  
Current

**Station Status & Setup**

## Control Mode Select

CONTROL MODE SELECT

Previous Screen

Master Control Mode

1

Parameter: P.091

- 1 = Level Control
- 2 = Flow Control
- 3 = Pressure Control
- 4 = Booster Control

# BOOSTER CONTROL - Touchscreen HMI

## Pump Setup

**PUMP SETUP**

[Previous Screen](#)

Number of Pumps Present   
Parameter: P.092

Maximum Number of Pumps Allowed To Run At The Same Time   
Parameter: P.093

Maximum Number of Pumps Allowed To Run While On Generator   
(See Discrete Input Function 18) Parameter: P.094

## Booster Control Main Screen

SC5000 BOOSTER CONTROL

[Main Screen](#)

Fault Code

FLC

LFC

[Pressure Setup](#) [Control Setup](#)

[Alternation Setup](#) [Alarms Setup](#)

[Controller Info.](#)

Parameter Security

PARAMETERS UNLOCKED

[Security Code Entry](#)

[Station Status](#)

# BOOSTER CONTROL - Touchscreen HMI SCREENS

## Station Status

The Station Status screen displays the operational status of six pumps and system pressures. It includes a grid of pump controls (OFF, DISABLE, FORCE, ELAPSED RUN TIME, RESET) and pressure monitoring (Supply and Discharge Pressure) with high and low alarm indicators. System status messages like 'Discharge Pressure Setpoint Override Active' and 'Supply Pressure Too Low for Pump Operation' are shown. A 'Previous Screen' button is located in the top right.

Supply Pressure	Discharge Pressure	Pump 1	Pump 2	Pump 3	Pump 4	Pump 5	Pump 6
High Alarm	High Alarm	Not Available For Service	Not Available For Service	Not Available For Service	Not Available For Service	Not Available For Service	Not Available For Service
123.4 psi	123.4 psi	OFF	OFF	OFF	OFF	OFF	OFF
Low Alarm	Low Alarm	DISABLE	DISABLE	DISABLE	DISABLE	DISABLE	DISABLE
		FORCE	FORCE	FORCE	FORCE	FORCE	FORCE
		1234.5	1234.5	1234.5	1234.5	1234.5	1234.5
		ELAPSED RUN TIME (HOURS)	ELAPSED RUN TIME (HOURS)	ELAPSED RUN TIME (HOURS)	ELAPSED RUN TIME (HOURS)	ELAPSED RUN TIME (HOURS)	ELAPSED RUN TIME (HOURS)
		RESET	RESET	RESET	RESET	RESET	RESET

Controlling Setpoint: 123.4 psi  
Discharge Pressure Setpoint Override Active  
Supply Pressure Too Low for Pump Operation  
All Pump Disable Active  
Pump Speed Reference: 123.4 %  
Pressure Setpoint: 123.4 psi  
Fault Code: FLC 1234, LFC 1234  
RESET

## Pressure Setup

The Pressure Setup screen allows for configuring the Discharge Pressure and Discharge Pressure Setpoint. It includes a 'Previous Screen' button and three main configuration options: Supply Pressure Input Setup, Discharge Pressure Input Setup, and PID Controller Tuning.

Discharge Pressure: 123.4 psi (Parameter: Pd.21)

Discharge Pressure Setpoint: 123.4 psi (Parameter: P.489)

Supply Pressure Input Setup  
Discharge Pressure Input Setup  
PID Controller Tuning

# BOOSTER CONTROL - Touchscreen HMI SCREENS

## Supply Pressure Input Setup

**SUPPLY PRESSURE INPUT SETUP**

[Previous Screen](#)

**Supply Pressure Input Select**

**1**

Parameter: P.481

1 = Pressure Meter APM1  
2 = Pressure Meter APM2

The selected Analog Pressure Meter APM1 or APM2 must be setup before using. To Setup go to the Main Screen and select "Pressure".

**Supply Pressure**

Parameter: Pd.12

**123.4** psi

Parameter: Pd.11

**Supply Pressure Input Bar Graph Span**

**123.4** psi

Parameter: P.482

## Discharge Pressure Input Setup

**DISCHARGE PRESSURE INPUT SETUP**

[Previous Screen](#)

**Discharge Pressure Input Select**

**1**

Parameter: P.485

1 = Pressure Meter APM1  
2 = Pressure Meter APM2

The selected Analog Pressure Meter APM1 or APM2 must be setup before using. To Setup go to the Main Screen and select "Pressure".

**Discharge Pressure**

Parameter: Pd.22

**123.4** psi

Parameter: Pd.21

**Discharge Pressure Input Bar Graph Span**

**123.4** psi

Parameter: P.486

# BOOSTER CONTROL - Touchscreen HMI SCREENS

## PID Controller Tuning

### PID CONTROLLER TUNING

Pump 1  Pump 2  Pump 3  Pump 4  Pump 5  Pump 6

Supply Pressure **123.4** psi    Discharge Pressure **123.4** psi  
Parameter: Pd.11    Parameter: Pd.21

Discharge Pressure Setpoint **123.4** psi    Controlling Setpoint **123.4** psi  
Parameter: P.489    Parameter: Pd.31

Pump Speed Reference **123.4** %  
Parameter: Pd.41

[Previous Screen](#)

---

Speed Reference Component Values

Proportional + **12,345,123**  
- **12,345,123**

Controller Gain (Kc) **12.34**  
Parameter: P.491

Integral Time (Ti) (minutes / repeat) **12.34**  
Parameter: P.492

Integral **12,345,123**

Derivative Time (Td) (minutes) **12.34**  
Parameter: P.493

Derivative + **12,345,123**  
- **12,345,123**

## Control Setup

### CONTROL SETUP

Setup To Turn On Pumps

Pump Speed Upper Threshold **123.4** %    **123** Delay To Turn On One Pump (seconds)  
Parameter: P.498    Parameter: P.499

Setup To Turn Off Pumps

Pump Speed Lower Threshold **123.4** %    **123** Delay To Turn Off One Pump (seconds)  
Parameter: P.500    Parameter: P.501

Minimum Pump Speed **12** %  
Parameter: P.502

[Previous Screen](#)

[Next Screen](#)



# BOOSTER CONTROL - Touchscreen HMI SCREENS

## Control Setup

**CONTROL SETUP**

[Previous Screen](#)

<p>Pump Operation Enable Supply Pressure</p> <p><b>123.4</b> psi</p> <p>Parameter: P.503</p>	<p>Pump Operation Enable Delay</p> <p><b>123</b> seconds</p> <p>Parameter: P.504</p>
<p>Pump Operation Disable Supply Pressure</p> <p><b>123.4</b> psi</p> <p>Parameter: P.505</p>	<p>Pump Operation Disable Delay</p> <p><b>123</b> seconds</p> <p>Parameter: P.506</p>

[Next Screen](#)

## Control Setup

**CONTROL SETUP**

[Previous Screen](#)

<p>Override Ramp Upper End Supply Pressure</p> <p><b>123.4</b> psi</p> <p>Parameter: P.508</p>	<p>Controlling Setpoint Lower Limit</p> <p><b>123.4</b> psi</p> <p>Parameter: P.507</p>
<p>Override Ramp Lower End Supply Pressure</p> <p><b>123.4</b> psi</p> <p>Parameter: P.509</p>	<p>Discharge Pressure Ramp Rate</p> <p><b>12.34</b> psi / sec</p> <p>Parameter: P.511</p>

[Next Screen](#)

# BOOSTER CONTROL - Touchscreen HMI SCREENS

## Control Setup

### CONTROL SETUP

[Previous Screen](#)

First Pump Start Delay

123

 seconds  
Parameter: P.514

Lag Pump Delay

123

 seconds  
Parameter: P.515

Number of Pumps  
Required at Startup

123

  
Parameter: P.516

[Next Screen](#)

## Control Setup

### CONTROL SETUP

[Previous Screen](#)

Pump Speed  
Acceleration Rate

123

 seconds / 100% speed  
(The time required to go from 0% to 100% speed.)  
Parameter: P.166

Pump Speed  
Deceleration Rate

123

 seconds / 100% speed  
(The time required to go from 100% to 0% speed.)  
Parameter: P.167

Note:  
The Controller performs the Acceleration and Deceleration of the pump speed.  
The Accel and Decel Parameters on the VFDs should be set to values less than  
or equal to what is set above.

# BOOSTER CONTROL - Touchscreen HMI SCREENS

## Pump Alternation Setup

[Previous Screen](#)

### PUMP ALTERNATION SETUP

Forced Lead Pump Position  Force Alternation  Current Lead Pump

Parameter: P.129 Parameter: Ad.01

0 = Alternate  
1 = Pump 1 Lead Pump  
2 = Pump 2 Lead Pump  
3 = Pump 3 Lead Pump  
4 = Pump 4 Lead Pump  
5 = Pump 5 Lead Pump  
6 = Pump 6 Lead Pump

Time Based Alternation  
(Internal Time Clock)

0 = Disabled  
60 = 1 hour  
480 = 8 hour  
1440 = 24 hour

minutes

Parameter: P.131

## Alarms Setup

[Previous Screen](#)

### ALARMS SETUP

High Supply Pressure Alarm

psi

Parameter: P.392

High Discharge Pressure Alarm

psi

Parameter: P.394

Low Supply Pressure Alarm

psi

Parameter: P.391

Low Discharge Pressure Alarm

psi

Parameter: P.393