

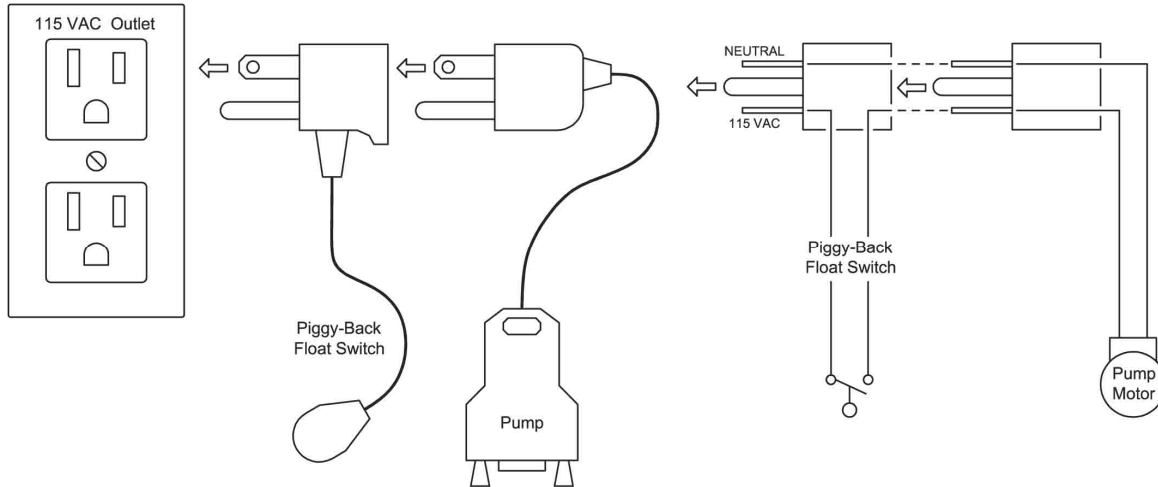

The Exerciser® SPEx-1

Application Note for The Exerciser® and Sump or Sewage Pumps using a Piggy-Back Float Switch

Connection Diagram - Original Configuration



Connection Diagram - With The Exerciser

The Exerciser must be plugged into a 115VAC Outlet, and the Pump and Piggy-Back Float Switch plugged into the Exerciser as shown below. The Shorting Plug must then be plugged into the back of the Piggy-Back Float Switch as shown below. The Shorting Plug allows the Piggy-Back Float Switch to be used as is, by turning the Piggy-Back Float Switch into a regular Float Switch.

